

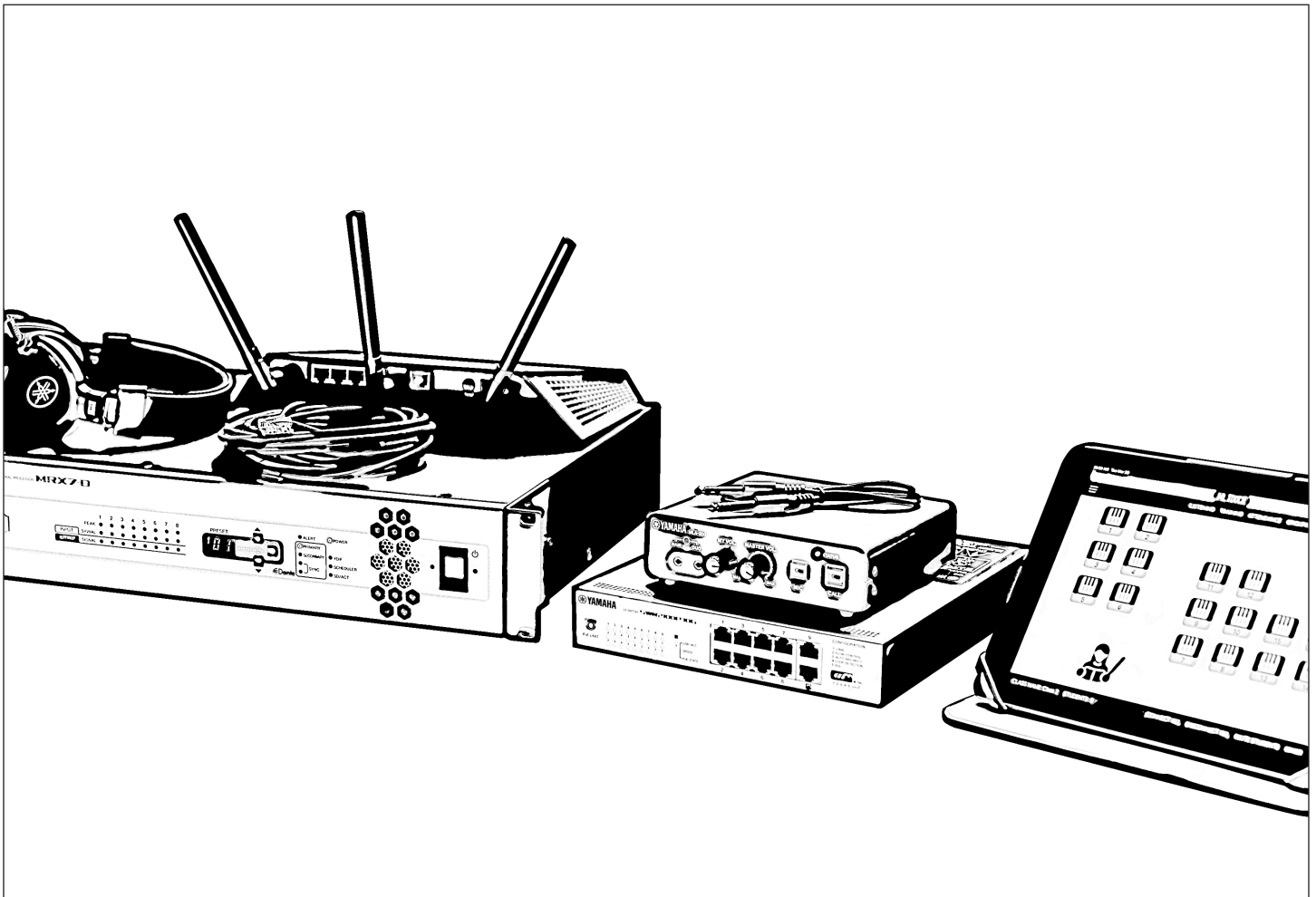

MUSIC LABORATORY CONTROLLER

MLC-200

Installation Guide



Contents

Introduction	3
Overview	3
Preparations	3
Workflow	4
1. Trial setup	5
2. Setting up the wireless access point (DHCP server)	5
3. Setting up MLA-200s	6
4. Setting up the MRX7-D	10
5. Setting up the audio network	11
6. Setting up the ML Touch App	15
7. Connecting audio devices	16
8. Operation check	16
9. Mounting MLA-200 onto instruments	18
Installation precautions (attaching to the instrument with included screws)	18
Installation procedure	18
Installation examples	20
When placed on a flat surface	22
10. Final operation check	23
11. Troubleshooting	24

Introduction

Customer Support

If you need assistance at any time during installation or when the MLC-200 system is in use, please contact Yamaha Customer Support at 714-522-9011 and when prompted to choose a support department, enter code 44.

Overview

The Yamaha Music Laboratory Controller is a music education system that combines Yamaha know-how in music education and electronics technology. This system is built to support communication between students and instructors and to provide more fluid guidance on individual and group performances. Instructors use the ML Touch application on an iPad to operate the entire system, such as checking students' performances, responding to questions and sending performance data.

This system combines MRX7-D as the core of the audio network and MLA-200 (with a master unit for the instructor and subordinate units for the students). Up to 24 subordinate units for students can be connected to one MRX7-D. At maximum, a system can be built to connect 96 subordinate units with four MRX7-Ds.

This Setup Guide provides the necessary information for building and setting up the MLC-200 in a classroom. We recommend that you read this information before and during setup.

Preparations

Items necessary for building the system

MLA-200	One for the instructor and a maximum of 96 for students.
MRX7-D	A maximum of one MLA-200 for the instructor and 24 MLA-200s for students can be connected to one MRX7-D. Up to four MRX7-Ds can be connected.
PoE powered Ethernet switch	A power supply of 6 W or more per port is required.
Ethernet cable	STP CAT5e (1000BASE-T) or higher grade STP cables are required. Prepare a total number of cables equal to the number of MLA-200s + the number of MRX7-Ds × 2 + the computer + the wireless access point + the Ethernet switch.
USB cable (Type AB)	Use to communicate MIDI data with the instrument. Prepare the same number as MLA-200s.
Audio cable	Use to connect the instrument and MLA-200. Prepare stereo cables with standard headphones plugs.
Headphones/microphone headset	With 3.5 mm mini plugs (CTIA compliant).
Wireless access point/DHCP server	Use for communication between the iPad application and the hardware. This device must be able to perform the DHCP server function of assigning addresses to both wireless devices and LAN devices.
Audio playback device (optional)	Use Audio/Video Device, etc., to play back audio teaching materials.
Microphone (optional)	For audio input by the instructor.
iPad	Use to operate the "ML Touch" control application for the instructor. iOS 12 or later is required.
ML Touch	This iPad application for instructors can be obtained for free from the App Store.

Items necessary only for setup

Windows computer	Use to specify settings during setup. A computer with an RJ-45 connector and running Windows 10, Windows 8.1 or Windows 7 is required.
ML Config Tool	This software automatically configures the audio network connection between the MRX7-Ds and MLA-200s. Install this software on a Windows computer.
Dante Controller	Use to change the audio network setup manually (for special settings) and to check the status of the system

Workflow

Follow the workflow below to build and set up the Music Laboratory System.

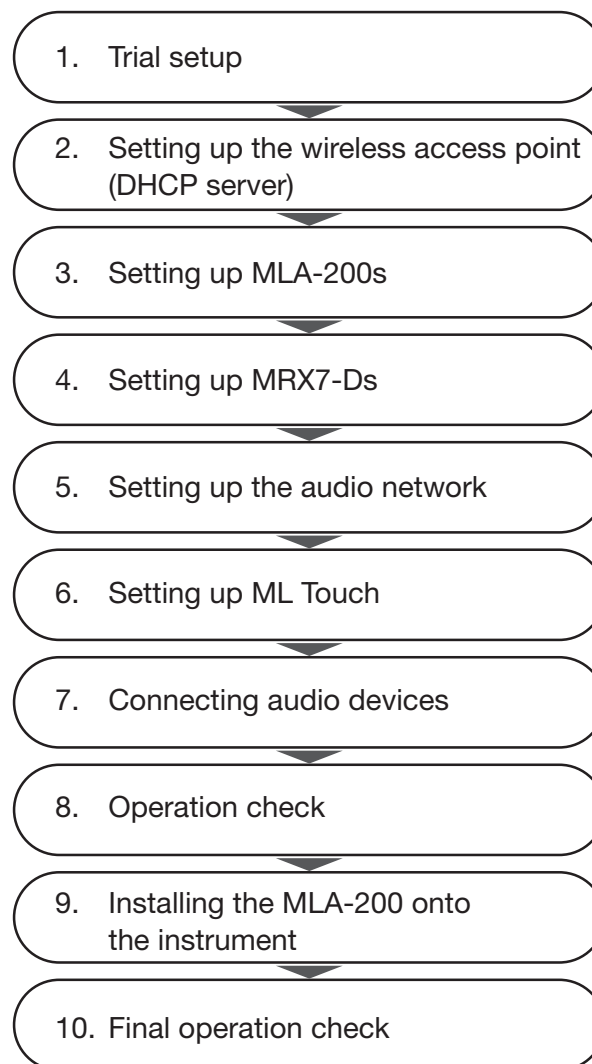

1. Trial setup

Before installing the devices in the classroom, perform a trial setup of the entire system to check the setup and operation of each device.

Since it will be difficult to remove and attach the DIP switch cover and change the DIP switch settings after the MLA-200 is installed onto an instrument, we recommend checking the setup and operation of each device prior to installation on the instrument.

2. Setting up the wireless access point (DHCP server)

The “ML Touch” application for the instructor communicates with each device via Wi-Fi. For that reason, the network must include a wireless access point.

The wireless access point used here must be able to perform the DHCP server function of assigning addresses to both wireless devices and LAN devices.

Connect the wireless access point to the Windows computer, and then set it up.

2-1. Connect the computer and wireless access point with an Ethernet cable.

2-2. Check IP Settings of the Computer

Select “Obtain an IP address automatically” in the “Internet Protocol Version 4 (TCP/IPv4) Properties” dialog box of “Network and Sharing Center” in the Windows Control Panel.

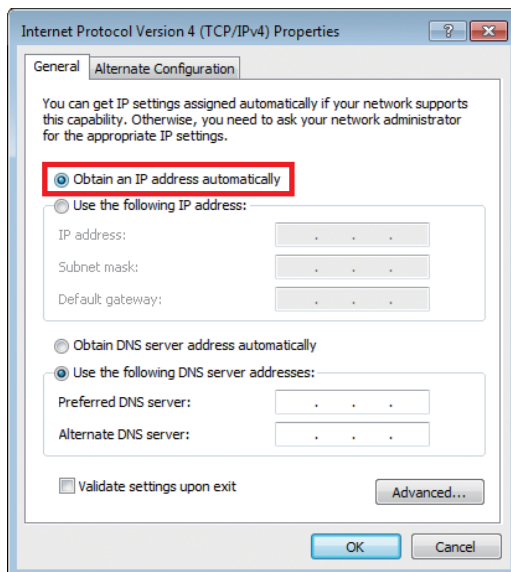

After selecting the setting, click the “OK” button.

This completes the network setup of the PC.

3. Setting up MLA-200s

Each MLA-200 in an audio network is differentiated by the unique ID that is specified. Specify this ID with the DIP switch.

3-1. With nothing connected, open the DIP switch cover on the rear panel.

One side of the cover remains attached. Disengage the side that does not remain attached, and then slowly open the cover.

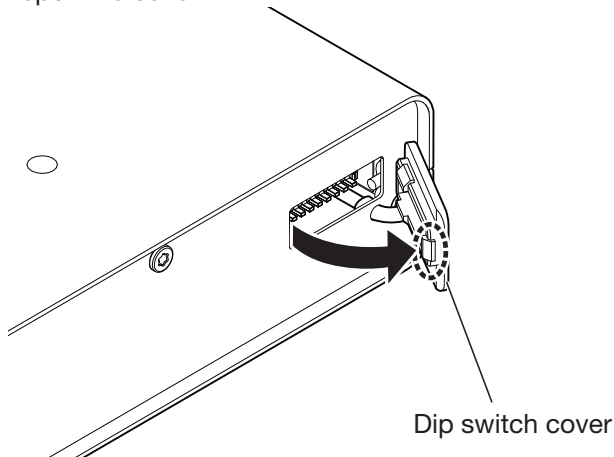

3-2. Set the DIP switch.

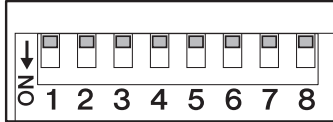

The switches of the DIP switch are set to ON when it is down and OFF when it is up. As a default, all switches are set to OFF (up).

NOTE

Be sure to view the DIP switch in its proper orientation.

Set the DIP switch for each MLA-200 according to the following tables.

Visit [Yamaha.io/MLA200Setup](https://yamaha.io/MLA200Setup) or scan the QR code below to utilize our MLA-200 Student Number Helper for DIP Switch Settings.

[Yamaha.io/MLA200Setup](https://yamaha.io/MLA200Setup)



3. Setting up MLA-200s — continued

Instructor and students 1 to 24 (MRX7-D ID=1)

	SW							
	1	2	3	4	5	6	7	8
Instructor	OFF	OFF	OFF	OFF	OFF	OFF	OFF	ON
Student 1	OFF	OFF	OFF	OFF	OFF	OFF	ON	OFF
Student 2	OFF	OFF	OFF	OFF	OFF	OFF	ON	ON
Student 3	OFF	OFF	OFF	OFF	OFF	ON	OFF	OFF
Student 4	OFF	OFF	OFF	OFF	OFF	ON	OFF	ON
Student 5	OFF	OFF	OFF	OFF	OFF	ON	ON	OFF
Student 6	OFF	OFF	OFF	OFF	OFF	ON	ON	ON
Student 7	OFF	OFF	OFF	OFF	ON	OFF	OFF	OFF
Student 8	OFF	OFF	OFF	OFF	ON	OFF	OFF	ON
Student 9	OFF	OFF	OFF	OFF	ON	OFF	ON	OFF
Student 10	OFF	OFF	OFF	OFF	ON	OFF	ON	ON
Student 11	OFF	OFF	OFF	OFF	ON	ON	OFF	OFF
Student 12	OFF	OFF	OFF	OFF	ON	ON	OFF	ON
Student 13	OFF	OFF	OFF	OFF	ON	ON	ON	OFF
Student 14	OFF	OFF	OFF	OFF	ON	ON	ON	ON
Student 15	OFF	OFF	OFF	ON	OFF	OFF	OFF	OFF
Student 16	OFF	OFF	OFF	ON	OFF	OFF	OFF	ON
Student 17	OFF	OFF	OFF	ON	OFF	OFF	ON	OFF
Student 18	OFF	OFF	OFF	ON	OFF	OFF	ON	ON
Student 19	OFF	OFF	OFF	ON	OFF	ON	OFF	OFF
Student 20	OFF	OFF	OFF	ON	OFF	ON	OFF	ON
Student 21	OFF	OFF	OFF	ON	OFF	ON	ON	OFF
Student 22	OFF	OFF	OFF	ON	OFF	ON	ON	ON
Student 23	OFF	OFF	OFF	ON	ON	OFF	OFF	OFF
Student 24	OFF	OFF	OFF	ON	ON	OFF	OFF	ON

3. Setting up MLA-200s — continued

Students 25 to 48 (MRX7-D ID=2)

	SW							
	1	2	3	4	5	6	7	8
Student 25	OFF	OFF	OFF	ON	ON	OFF	ON	OFF
Student 26	OFF	OFF	OFF	ON	ON	OFF	ON	ON
Student 27	OFF	OFF	OFF	ON	ON	ON	OFF	OFF
Student 28	OFF	OFF	OFF	ON	ON	ON	OFF	ON
Student 29	OFF	OFF	OFF	ON	ON	ON	ON	OFF
Student 30	OFF	OFF	OFF	ON	ON	ON	ON	ON
Student 31	OFF	OFF	ON	OFF	OFF	OFF	OFF	OFF
Student 32	OFF	OFF	ON	OFF	OFF	OFF	OFF	ON
Student 33	OFF	OFF	ON	OFF	OFF	OFF	ON	OFF
Student 34	OFF	OFF	ON	OFF	OFF	OFF	ON	ON
Student 35	OFF	OFF	ON	OFF	OFF	ON	OFF	OFF
Student 36	OFF	OFF	ON	OFF	OFF	ON	OFF	ON
Student 37	OFF	OFF	ON	OFF	OFF	ON	ON	OFF
Student 38	OFF	OFF	ON	OFF	OFF	ON	ON	ON
Student 39	OFF	OFF	ON	OFF	ON	OFF	OFF	OFF
Student 40	OFF	OFF	ON	OFF	ON	OFF	OFF	ON
Student 41	OFF	OFF	ON	OFF	ON	OFF	ON	OFF
Student 42	OFF	OFF	ON	OFF	ON	OFF	ON	ON
Student 43	OFF	OFF	ON	OFF	ON	ON	OFF	OFF
Student 44	OFF	OFF	ON	OFF	ON	ON	OFF	ON
Student 45	OFF	OFF	ON	OFF	ON	ON	ON	OFF
Student 46	OFF	OFF	ON	OFF	ON	ON	ON	ON
Student 47	OFF	OFF	ON	ON	OFF	OFF	OFF	OFF
Student 48	OFF	OFF	ON	ON	OFF	OFF	OFF	ON

3. Setting up MLA-200s — continued

Students 49 to 72 (MRX7-D ID=3)

	SW							
	1	2	3	4	5	6	7	8
Student 49	OFF	OFF	ON	ON	OFF	OFF	ON	OFF
Student 50	OFF	OFF	ON	ON	OFF	OFF	ON	ON
Student 51	OFF	OFF	ON	ON	OFF	ON	OFF	OFF
Student 52	OFF	OFF	ON	ON	OFF	ON	OFF	ON
Student 53	OFF	OFF	ON	ON	OFF	ON	ON	OFF
Student 54	OFF	OFF	ON	ON	OFF	ON	ON	ON
Student 55	OFF	OFF	ON	ON	ON	ON	OFF	OFF
Student 56	OFF	OFF	ON	ON	ON	ON	OFF	ON
Student 57	OFF	OFF	ON	ON	ON	ON	ON	OFF
Student 58	OFF	OFF	ON	ON	ON	ON	ON	ON
Student 59	OFF	OFF	ON	ON	ON	ON	OFF	OFF
Student 60	OFF	OFF	ON	ON	ON	ON	OFF	ON
Student 61	OFF	OFF	ON	ON	ON	ON	ON	OFF
Student 62	OFF	OFF	ON	ON	ON	ON	ON	ON
Student 63	OFF	ON	OFF	OFF	OFF	OFF	OFF	OFF
Student 64	OFF	ON	OFF	OFF	OFF	OFF	OFF	ON
Student 65	OFF	ON	OFF	OFF	OFF	OFF	ON	OFF
Student 66	OFF	ON	OFF	OFF	OFF	OFF	ON	ON
Student 67	OFF	ON	OFF	OFF	OFF	ON	OFF	OFF
Student 68	OFF	ON	OFF	OFF	OFF	ON	OFF	ON
Student 69	OFF	ON	OFF	OFF	OFF	ON	ON	OFF
Student 70	OFF	ON	OFF	OFF	OFF	ON	ON	ON
Student 71	OFF	ON	OFF	OFF	ON	OFF	OFF	OFF
Student 72	OFF	ON	OFF	OFF	ON	OFF	OFF	ON

3. Setting up MLA-200s — continued

Students 73 to 96 (MRX7-D ID=4)

	SW							
	1	2	3	4	5	6	7	8
Student 73	OFF	ON	OFF	ON	ON	OFF	ON	OFF
Student 74	OFF	ON	OFF	ON	ON	OFF	ON	ON
Student 75	OFF	ON	OFF	ON	ON	ON	OFF	OFF
Student 76	OFF	ON	OFF	ON	ON	ON	OFF	ON
Student 77	OFF	ON	OFF	ON	ON	ON	ON	OFF
Student 78	OFF	ON	OFF	ON	ON	ON	ON	ON
Student 79	OFF	ON	OFF	ON	OFF	OFF	OFF	OFF
Student 80	OFF	ON	OFF	ON	OFF	OFF	OFF	ON
Student 81	OFF	ON	OFF	ON	OFF	OFF	ON	OFF
Student 82	OFF	ON	OFF	ON	OFF	OFF	ON	ON
Student 83	OFF	ON	OFF	ON	OFF	ON	OFF	OFF
Student 84	OFF	ON	OFF	ON	OFF	ON	OFF	ON
Student 85	OFF	ON	OFF	ON	OFF	ON	ON	OFF
Student 86	OFF	ON	OFF	ON	OFF	ON	ON	ON
Student 87	OFF	ON	OFF	OFF	ON	OFF	OFF	OFF
Student 88	OFF	ON	OFF	OFF	ON	OFF	OFF	ON
Student 89	OFF	ON	OFF	OFF	ON	OFF	ON	OFF
Student 90	OFF	ON	OFF	OFF	ON	OFF	ON	ON
Student 91	OFF	ON	OFF	OFF	ON	ON	OFF	OFF
Student 92	OFF	ON	OFF	OFF	ON	ON	OFF	ON
Student 93	OFF	ON	OFF	OFF	ON	ON	ON	OFF
Student 94	OFF	ON	OFF	OFF	ON	ON	ON	ON
Student 95	OFF	ON	ON	OFF	OFF	OFF	OFF	OFF
Student 96	OFF	ON	ON	OFF	OFF	OFF	OFF	ON

4. Setting up MRX7-Ds

For details on Labs greater than 24 students, please contact Yamaha Customer Support at 714.522.9011 and when prompted to choose a support department, enter code 44 for assistance and important configuration downloads.

4-1. Before turning on MRX7-D, set the rotary switch and DIP switch.

Specify the following settings.

MRX7-D ID=1 (instructor and students 1 to 24)

Rotary switch=1, DIP switch=All switches set to OFF (up)

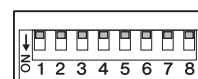

5. Setting up the Dante Audio Network

Communications between the instructor and students as well as audio of the performance is sent and received through the audio network. In the MLC200 Music Laboratory System, Dante has been adopted as the structure of the audio network. Although software called Dante Controller is normally used to set up a Dante audio network, its high degree of flexibility requires knowledge about audio networks.

Therefore, the dedicated software ML Config Tool is used in the MLC200 Music Laboratory System to make setup easier. Download the ML Config Tool Software here: Yamaha.io/MLCdownloads

5-1. Connect all MLA-200s to Ethernet switches.

The [STATUS] indicator flashes while the device is starting up. The indicator lights up when the device is finished starting up.

Check that the [STATUS] indicator of all MLA-200s are lit.

Connection diagram showing 8 students.

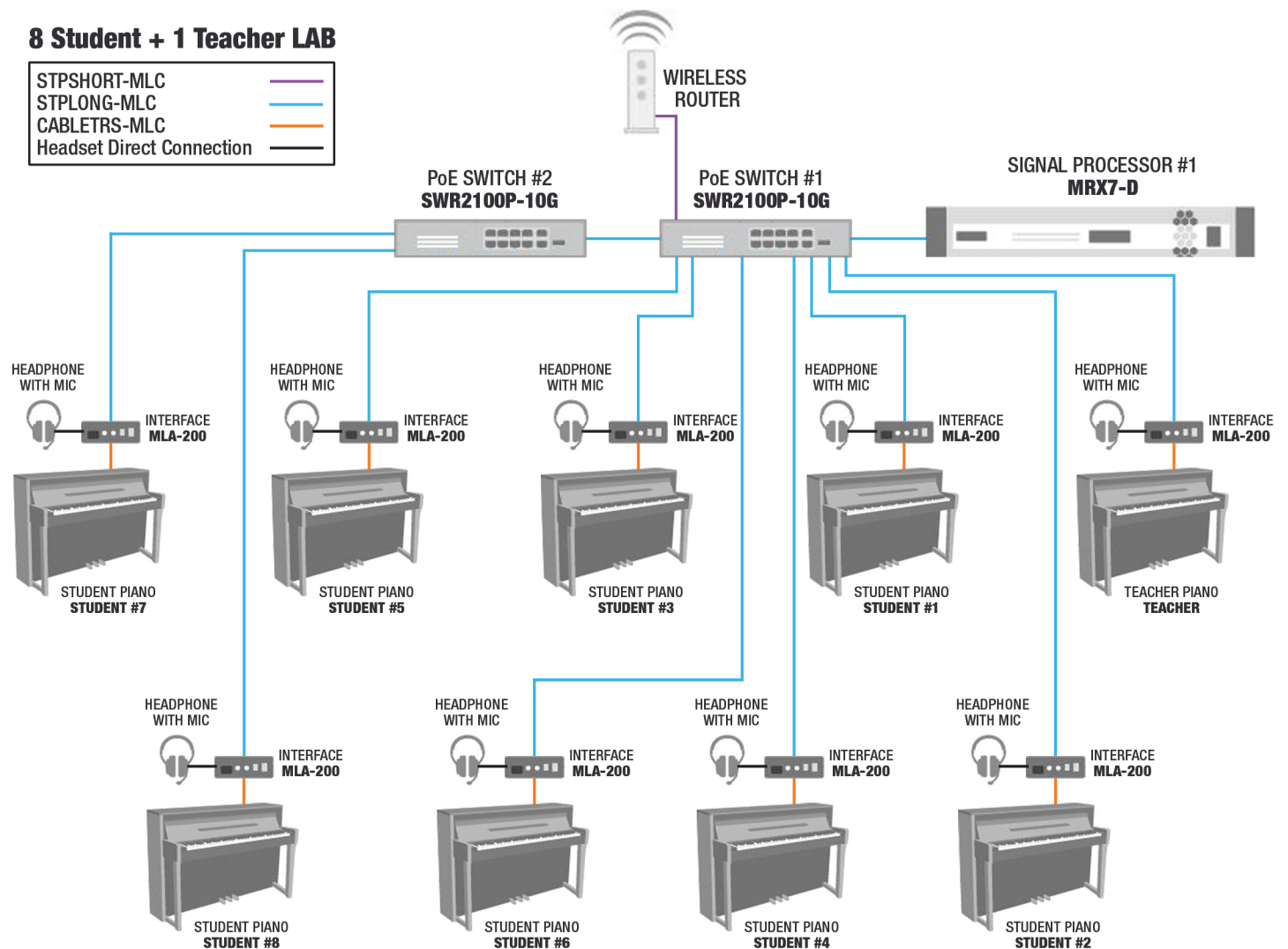

5. Setting up the Dante Audio Network — continued

Connection diagram showing 15 students.

15 Student + 1 Teacher LAB

STPSHORT-MLC	
STPLONG-MLC	
CABLETRS-MLC	
Headset Direct Connection	

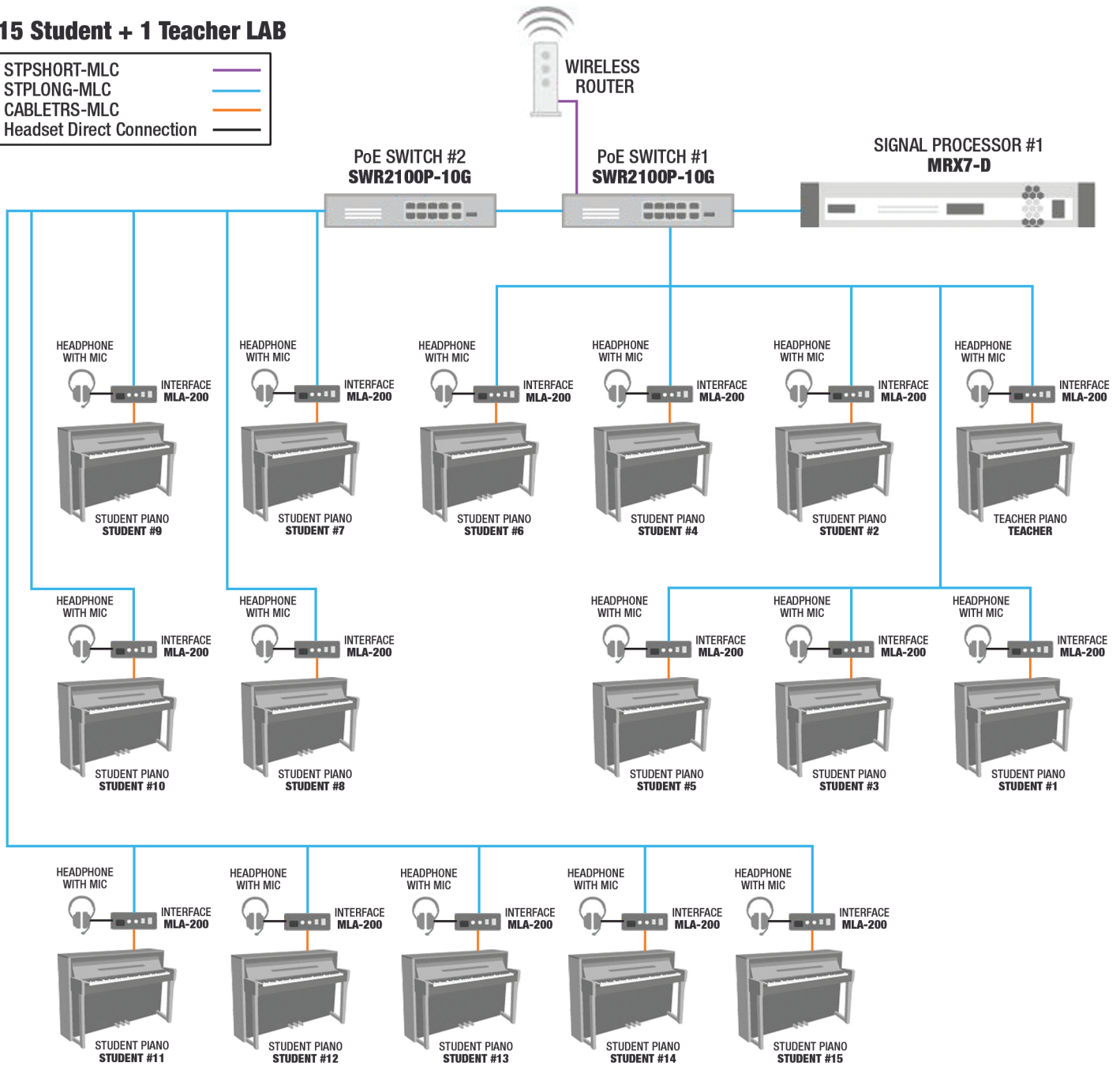

NOTE

- Before making connections, be sure to complete the procedure in “3. Setting up MLA-200s” (Page 6). The changes to the DIP switch settings are applied when the Ethernet cable is connected and the MLA-200 is turned on. Before changing the settings, unplug the Ethernet cable from the MLA-200.

5. Setting up the Dante Audio Network — continued

Connection diagram showing 24 students.

24 Student + 1 Teacher LAB

STPSHORT-MLC	
STPLONG-MLC	
CABLETRS-MLC	
Headset Direct Connection	

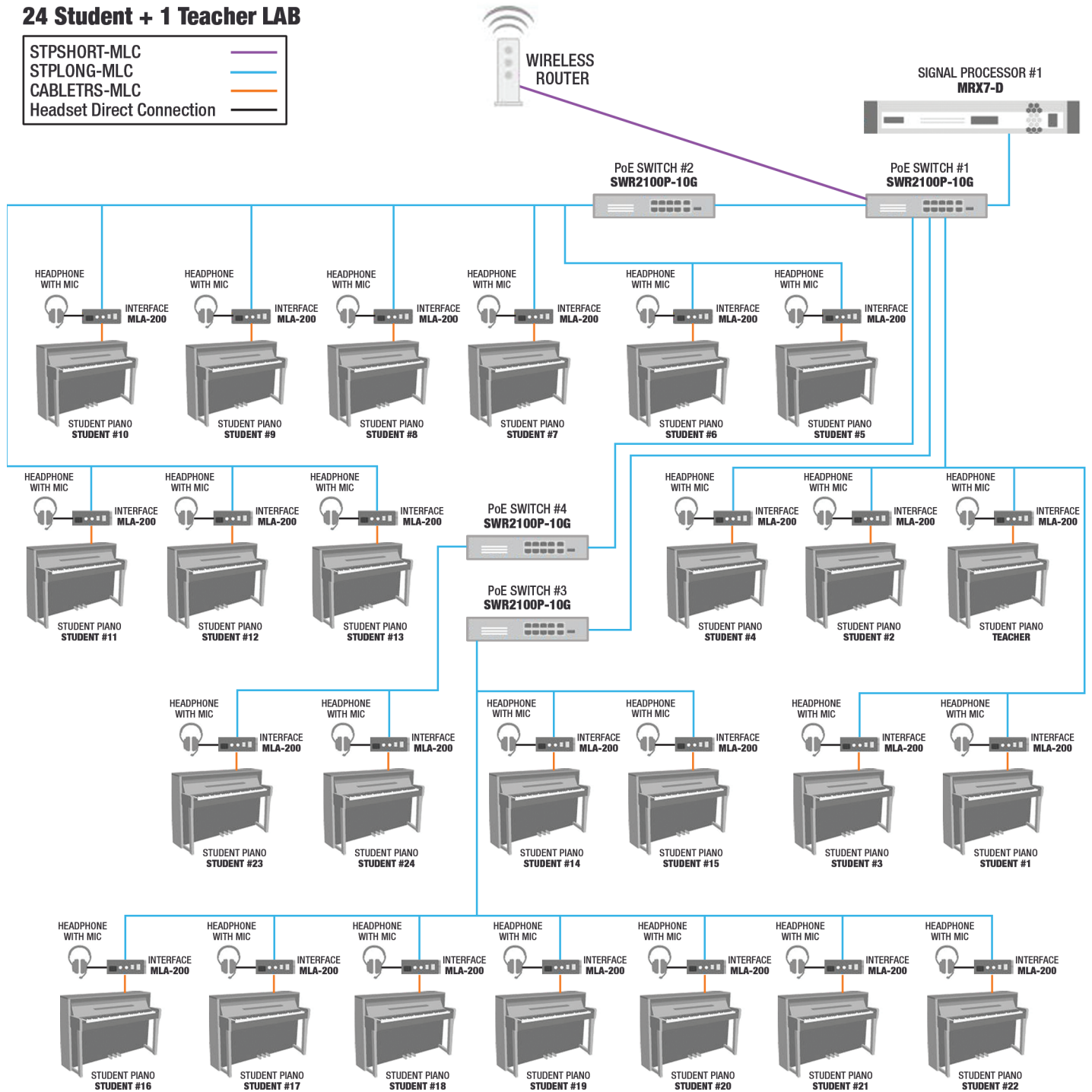

5. Setting up Dante Audio Network — continued

5-2. Start the ML Config Tool installed onto the Windows computer.

A window appears. Follow on screen steps to set up the Lab System.

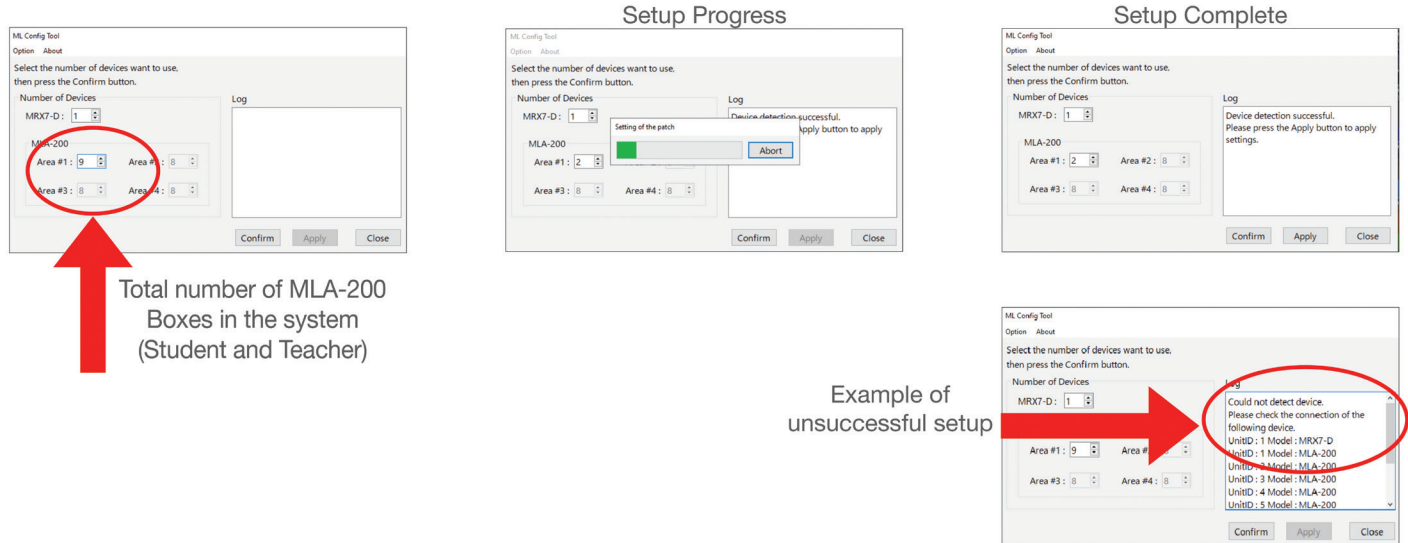

5-3. In “The number of MLA-200” box, type the number of MLA-200s connected

Include the MLA-200 for the instructor with the number of devices for Area #1. Area #1 can be set between 2 (for 1 instructor + 1 student) and 25 (for 1 instructor + 24 students); Area #2 to #4 can be set between 1 (for 1 student) and 24 (for 24 students).

5-4. Click the “Confirm” button.

The software automatically checks that the MRX7-Ds and MLA-200s are correctly set up. If they are correctly set up, “Succeed” appears in the “Output” box on the right side of the window. If this does not appear, return to the previous steps and check each of the settings.

5-5. Check that “Succeed” appears, and then click the “Apply” button.

This completes the setup of the audio network.

6. Setting up ML Touch

ML Touch is an iPad application used by instructors to operate the entire system. It can be downloaded from the App Store.

This describes the setup operations that must be performed before the application can be used. For details on using ML Touch, refer to the ML Touch User's Guide.



Scan here to download from the app store.

6-1. Download ML Touch from the App Store.

6-2. Tap the ML Touch icon to start the application.

The initial setup window appears.

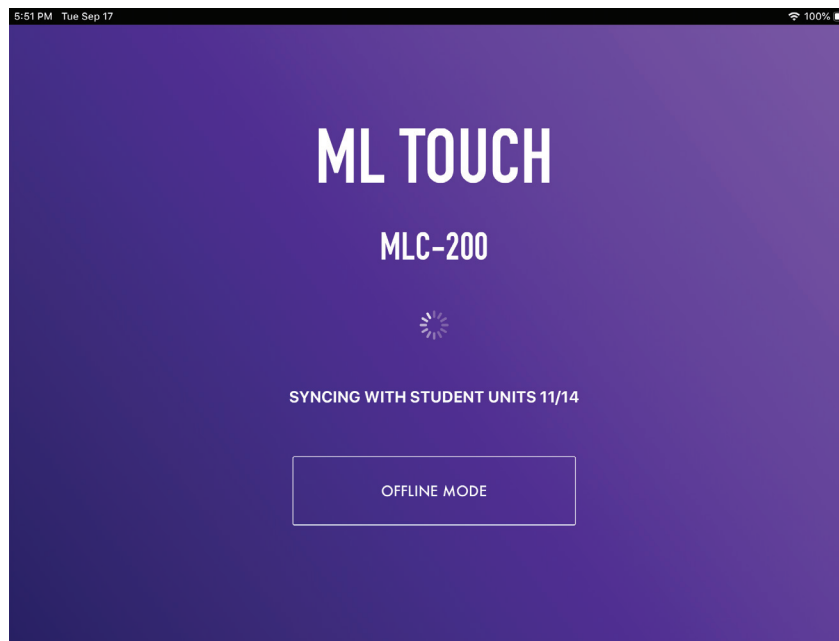

Next: The Home Window should appear. If an error appears, check the following:

- Are the MLC-200s connected correctly and are there no duplicate Unit IDs?

If an error appeared, the Home window does not appear. Force quit ML Touch app and relaunch.

If the iPad is not connected via Wi-Fi adjust settings in iOS. Refer to Step 7 in the Quick Setup Guide.

This completes the setup of ML Touch.

7. Connecting optional audio devices

Connect audio devices, such as the instructor's microphone or Audio/Video Device used for teaching, to the MRX7-D set to ID=1.

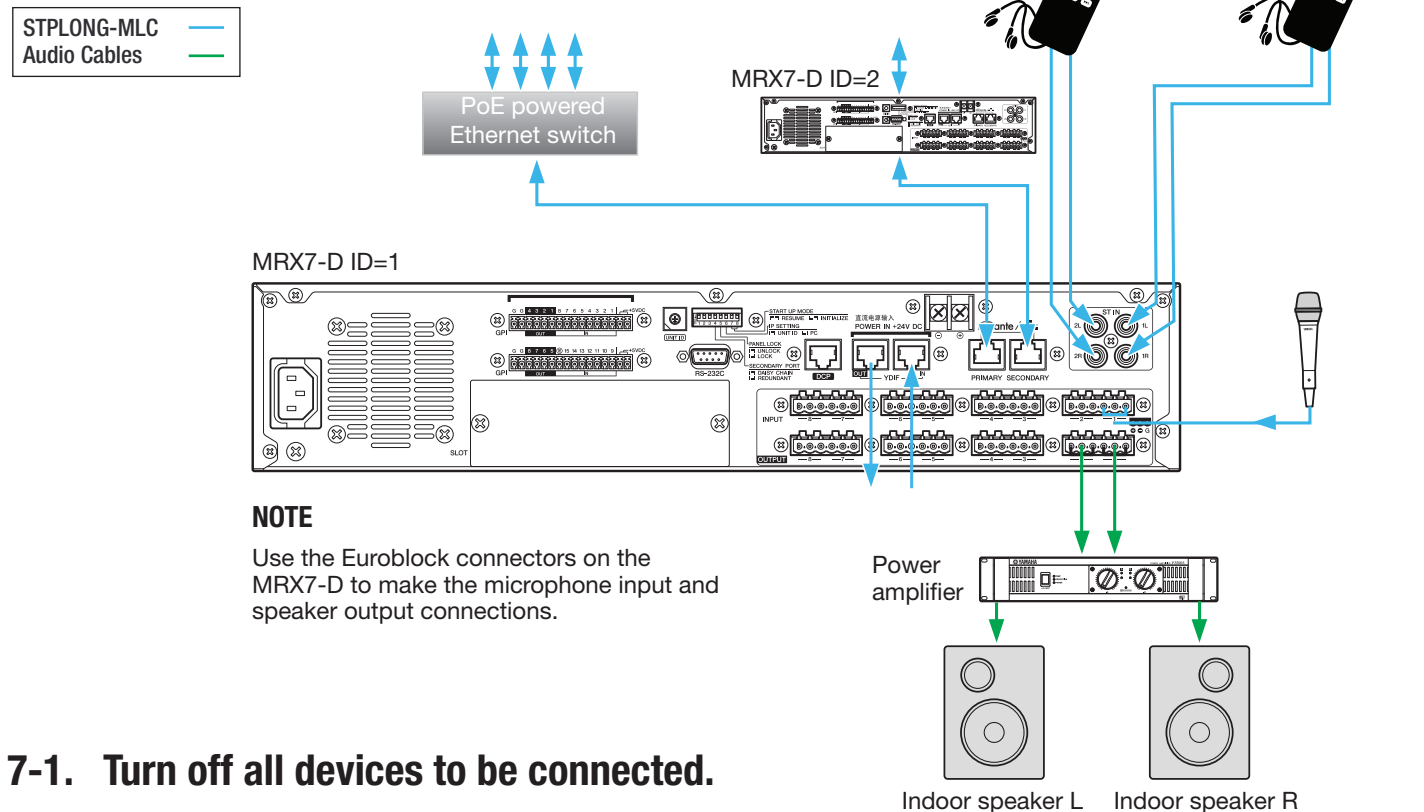

7-1. Turn off all devices to be connected.

7-2. Connect the audio devices as shown above.

Use the Euroblock connectors on the MRX7-D to make connections for the microphone input and power amplifier (powered speakers). For details on using the Euroblock connectors, refer to “Euroblock plug connection” in the MRX7-D Owner’s Manual.

When using multiple MRX7-Ds, connect via YDIF ports.

7-3. Turn on the MRX7-D.

When using multiple MRX7-D, turn on in order, starting with ID=1.

7-4. Turn on the power amplifier (powered speakers).

7-5. Start ML Touch.

7-6. Adjust the volume of the power amplifier.

At this time, adjust the volume to check that the connection has been made. If no sound is heard from the speakers, return to the previous steps and perform each one again. This completes the connection of the audio devices.

8. Operation check

Refer to page 10 of Quick Setup Guide for Testing and Troubleshooting.

9. Installing onto an instrument (optional)

After performing the operation check, unplug all cables connected to the MLA-200s, and then install the MLA-200 onto the instrument.

The MLA-200 can be installed in the following two ways:

- Attaching to the instrument with the included mounting screws
- Placing on a flat surface of the instrument with the included rubber feet

Installation precautions (attaching to the instrument with included screws)

- Install so that the cables on the side panel face downward
- Install so that there is no interference with headphones or connectors on the instrument
- Install so that the knobs of the MLA-200 and connected cables do not extend past the body of the instrument
- Be careful not to trip over connected cables while performing operations
- Be sure to use the included screws for the installation
- In order to prevent wood parts of the instrument from cracking, install the screws at least 15 mm inside the edge of the leg or stand of the instrument onto which the MLA-200 is mounted

Installation procedure

9-1. Attach the mounting bracket to the MLA-200.

Use the included mounting screws for installing the product.

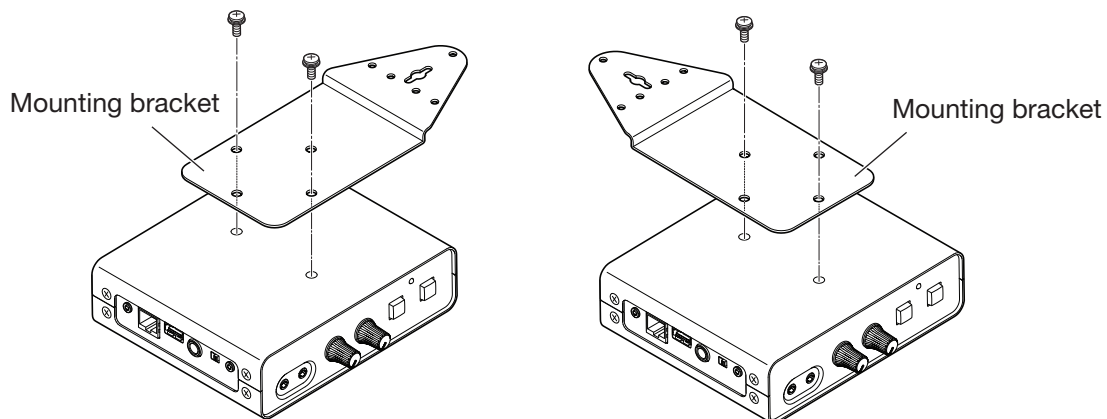

9. Installing onto an instrument (optional) — continued

9-2. While holding the MLA-200 in the desired position, drill four holes (for attaching the mounting bracket) into the instrument's stand (leg).

Drill holes with a depth of 15 mm and diameter of 2.5 mm at the center of the screw holes, positioned at least 15 mm inside the edge of the stand (leg). Be careful not to drill the holes too deep. In addition, be sure to drill all four holes.

NOTE

If the exterior of the instrument has a polished (mirror) finish, also countersink the holes to about 6 to 6.5 mm in diameter.

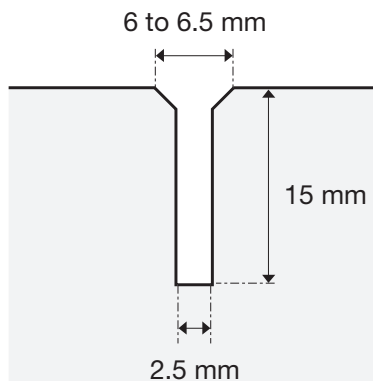

9-3. Drive in the center screw about halfway.



9-4. Hook the guide hole at the center of the mounting bracket onto the center screw.

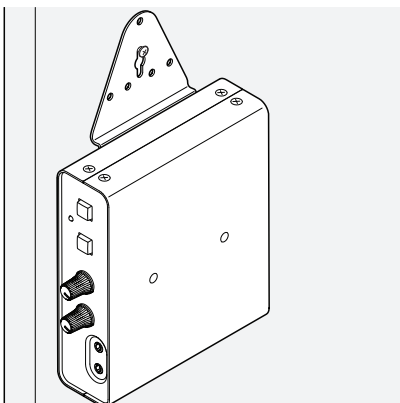

9. Installing onto an instrument (optional) — continued

9-5. Install and tighten the other screws.

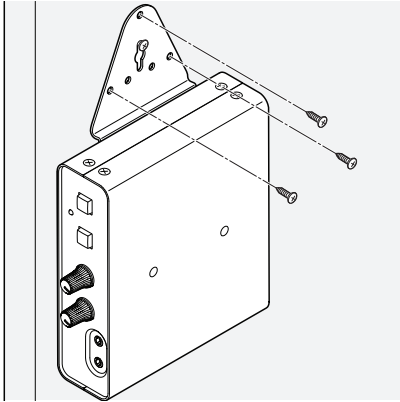

9-6. Tighten the center screw last.

9-7. Make sure that all screws are properly tightened.

This completes the installation onto the instrument.

Installation examples

Mounted with screws at the top

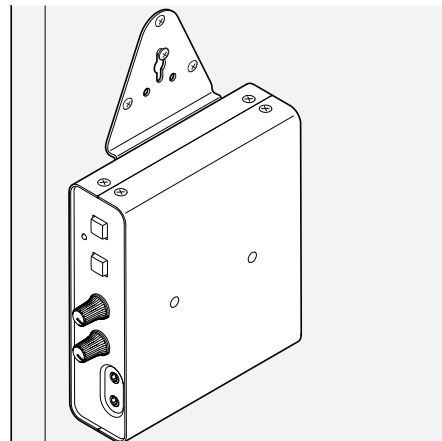
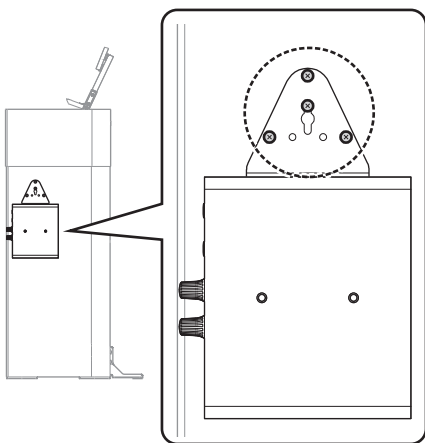

This is the most common installation method. Use this method when the stand (leg) of the instrument is wide.

9. Installing onto an instrument — continued

Mounted with screws on the side

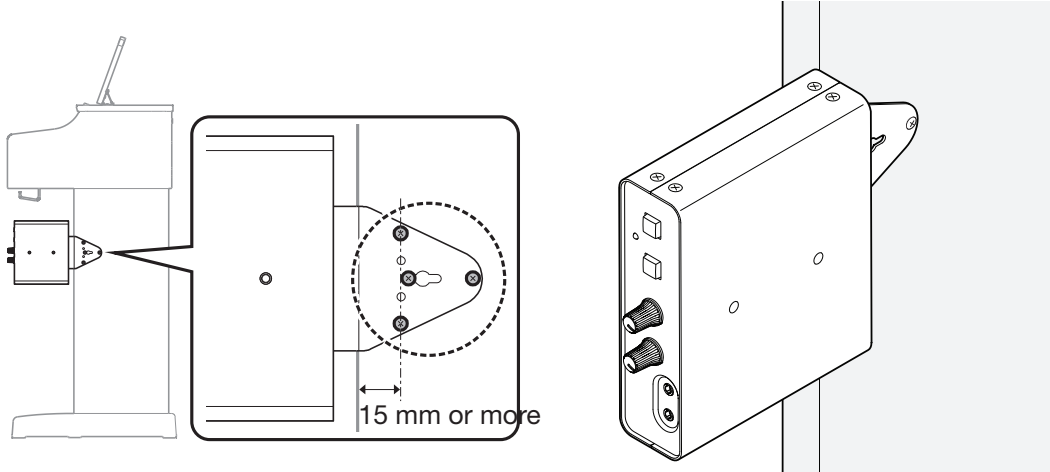

Use this installation method when the instrument stand is toward the back of the keyboard.

As described in “Installation precautions (attaching to the instrument with included screws)” (Page 18), maintain a distance of 15 mm or more between the center screw and the edge of the stand, and install by using all four screws.

Mounted with screws at the bottom

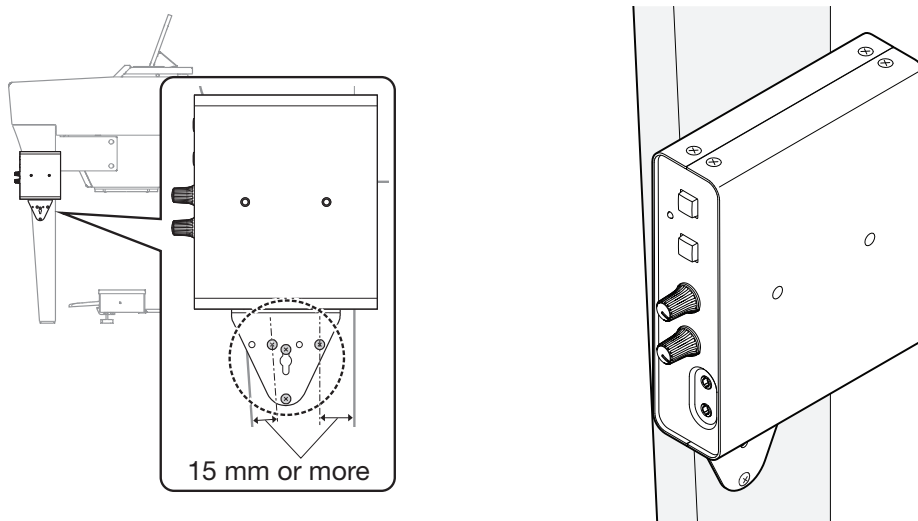

If the instrument has a thin stand, mount the MLA-200 with the screws at the top, or at the bottom using this installation method. With this method, also maintain a distance of 15 mm or more between the center screw and the edge of the stand, and install by using all four screws, as described in “Installation precautions (attaching to the instrument with included screws)” (Page 18).

9. Installing onto an instrument — continued

When placed on a flat surface

When placed on a flat surface of the instrument, be sure to attach the included rubber feet to prevent slipping.

The installation positions should be about 15 mm inside each edge as shown below. Be sure to attach all four.



Caution

**Position the MLA-200 so that no one will trip
and nothing will catch on the cables.**

If the MLA-200 falls, it may be damaged or cause injuries.

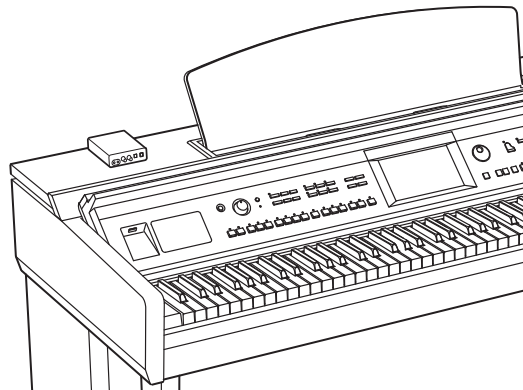
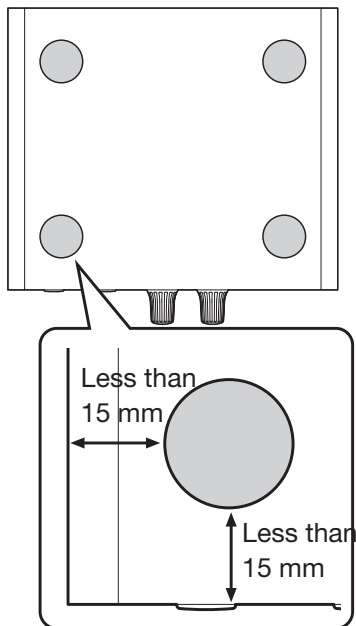

10. Final operation check

After installing the MLA-200s onto instruments and setting up the devices, reconnect the cables, and then perform the final operation check.

The procedure for this operation check is the same as that described in “8. Operation check” (Page 17), but this time the operation is checked after setting up the system in the classroom.

**10-1. Check that the MLA-200 for the instructor can be operated from ML Touch.
If audio devices such as a Microphone or Audio player are connected,
check their levels in the ML Touch App.**

10-2. Check the communication between ML Touch and the MLA-200s for students.

This completes the final operation check.

11. Troubleshooting

Symptom	Cause	Remedy
MLA-200 does not turn on	The Ethernet cable is disconnected	Reconnect Ethernet cable
	PoE power is not supplied by the network switch	Make sure that a PoE powered Ethernet switch is used
	The PoE power supplied by the network switch is insufficient	Check the power supply specifications of the Ethernet switch
No sound is output/ minimal sound is output	The [MASTER VOL.] knob or [MY VOL.] knob is incorrectly adjusted	Make sure that both knobs are turned to the 12 o'clock position
	Headphones are incorrectly connected	Disconnect, and then reconnect
		Change to a microphone headset compatible with the CTIA standard
The [INPUT GAIN] switch is incorrectly set	Make sure the [INPUT GAIN] switch is set to "+10 dB"	
HPH250M Microphone is not properly picking up your voice	HPH250M Microphone is not properly connected (A conversion cable that converts from the OMTP standard to the CTIA standard is being used)	Make sure markings on Mic Jack line up with the Markings on the Headphone input Jack. Make sure the microphone is completely inserted.
The sound from the microphone is not transmitted to the other party	A microphone headset that is not compatible with the CTIA standard is being used	Change to a microphone headset compatible with the CTIA standard
	The microphone headset is connected to the [DUO] jack	Connect the microphone headset to the [MAIN] jack. A microphone headset connected to the [DUO] jack operates only when a microphone headset is also connected to the [MAIN] jack (DUO mode)
Cannot communicate with ML Touch	The wireless access point and iPad are not connected	Check the Wi-Fi settings for the iPad, and then correctly select the specified wireless access point
	The DIP switch settings on the MLA-200 are incorrect Scan QR code in section 4 for MLA200 Student Dipswitch Helper.	Check that the ID specified with the DIP switch is the intended ID
	The ID of the MRX7-D is incorrectly specified	Check that the ID of the MRX7-D is the intended ID
One or more MLA-200 boxes have been replaced and ML Touch App is not recognizing units		Run ML Config Tool from Windows PC