

Block Diagrams

STAGEPAS 500

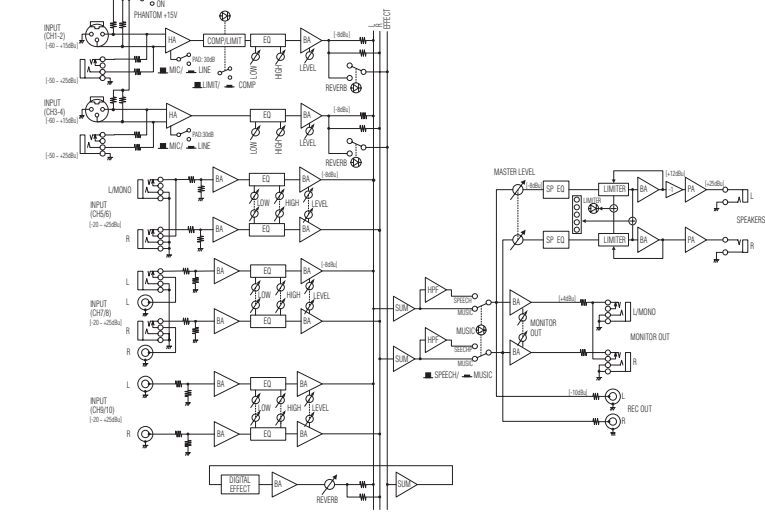

STAGEPAS 300

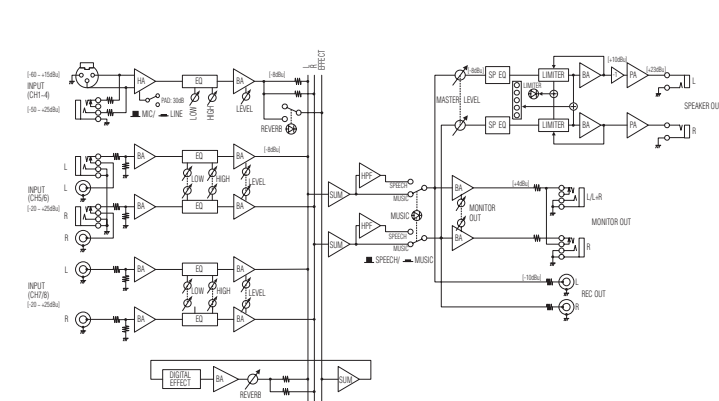

STAGEPAS 250M

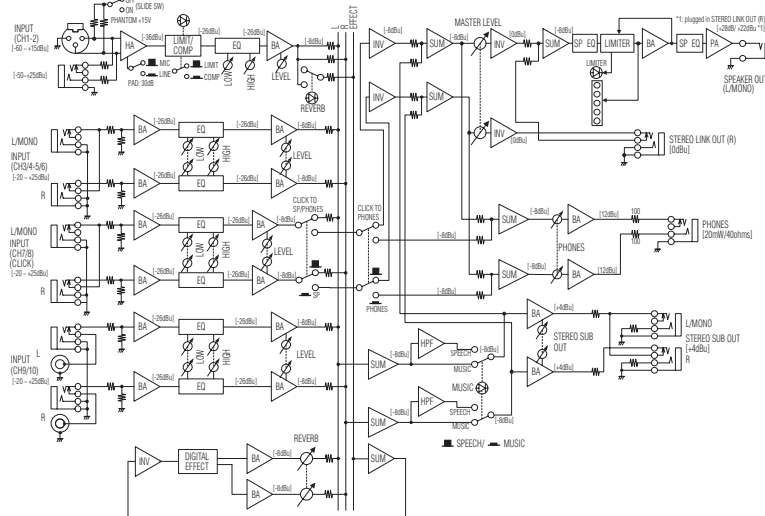

STAGEPAS 150M

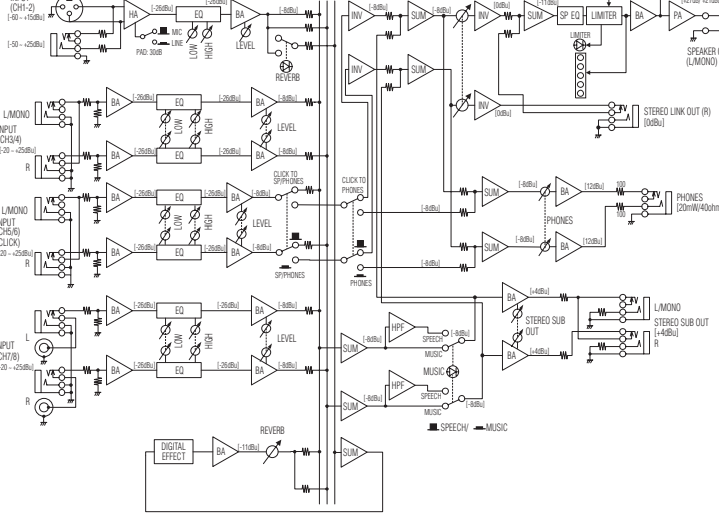

General Specifications (Mixer)

	STAGEPAS 500	STAGEPAS 300	STAGEPAS 250M	STAGEPAS 150M
Maximum Output Power	250 W + 250 W (±10 %)	150 W+150 W (±10 %)	150 W (±10 %)	150 W (±10 %)
	4 Ω @ 10 % THD at 1 kHz (SPEAKER L/R)	6 Ω @ 10 % THD at 1 kHz (SPEAKER L/R)	4 Ω @ 10 % THD at 1 kHz (SPEAKER)	6 Ω @ 10 % THD at 1 kHz (SPEAKER)
Output Power (RMS)	200 W + 200 W	100 W+100 W	200 W	100 W
	4Ω @ 1 % THD at 1 kHz (SPEAKER L/R)	6 Ω @ 1 % THD at 1 kHz (SPEAKER L/R)	4 Ω @ 1 % THD at 1 kHz (SPEAKER)	4 Ω @ 1 % THD at 1 kHz (SPEAKER)
Frequency Response (Nominal output level @ 1 kHz)		-3 dB, 0 dB, +1 dB @ 20 Hz-20 kHz, 1 W Output (MUSIC/SPEECH=MUSIC, without Speaker EQ) (STAGEPAS 500/300: SPEAKER L/R) (STAGEPAS 250M/150M: SPEAKER)		
Total Harmonic Distortion		0.5 % @ 20 Hz, 1 kHz, 20 kHz +14 dBu GAIN= nominal (STAGEPAS 500/300: MONITOR OUT, REC OUT) (STAGEPAS 250M/150M: ST SUB OUT, ST LINK OUT)		
Hum & Noise (Equivalent Input Noise, Rs = 150 Ω, MIC/LINE = MIC)	≤ -106 dBu (CH1/2) ≤ -112 dBu (CH3/4) ≤ -65 dBu Residual output noise (SPEAKER L/R)	≤ -65 dBu Residual output noise (SPEAKER L/R)	≤ -106 dBu (CH1/2) ≤ -65 dBu Residual output noise (SPEAKER)	≤ -112 dBu (CH3/4) ≤ -65 dBu Residual output noise (SPEAKER)
Crosstalk (1 kHz)		-70dB between input channels		
Input Channel Equalization		±15 dB, HIGH 10 kHz shelving, LOW 100 Hz shelving		
Power Consumption	65 W	70 W	35 W	20 W
Weight	24 kg (52-7/8" lbs.) (Speaker x 2 + Powered Mixer)	18 kg (39-5/8" lbs.) (Speaker x 2 + Powered Mixer)	13 kg (28-5/8" lbs.) (Speaker + Powered Mixer)	9.6 kg (21-1/8" lbs.) (Speaker + Powered Mixer)

General Specifications (Speaker)

	STAGEPAS 500	STAGEPAS 300	STAGEPAS 250M	STAGEPAS 150M
Enclosure		2-way bass-reflex type, Polypropylene, Black		
Crossover Frequency		4.0 kHz (LF: 12 dB/oct, HF: 12 dB/oct)		
Frequency Range		55 Hz-20 kHz (-10 dB)		
Maximum Output Level	116 dB (1 m)	112 dB (1 m)	116 dB (1 m)	112 dB (1 m)
Speaker Unit	LF: 10" (25 cm) Cone HF: 1" (2.54 cm) Compression Driver	LF: 8" (20 cm) Cone HF: 1" (2.54 cm) Compression driver	LF: 10" (25 cm) Cone HF: 1" (2.54 cm) Compression Driver	LF: 8" (20 cm) Cone HF: 1" (2.54 cm) Compression Driver

• Specifications and appearance subject to change without notice. • All trademarks and registered trademarks are property of their respective owners.

For details please contact:



This document is printed on chlorine-free (ECF) paper with soy ink.

PORTABLE PA SYSTEM

STAGEPAS Series



PORTABLE PA SYSTEM
STAGEPAS 500

PORTABLE PA SYSTEM
STAGEPAS 300

PORTABLE PA SYSTEM / KEYBOARD AMPLIFIER
STAGEPAS 250M

PORTABLE PA SYSTEM / KEYBOARD AMPLIFIER
STAGEPAS 150M

Power to Go!

Versatility and Power—in Four Portable Systems

Combining high-performance power and accurate sound reproduction with remarkable versatility in a portable package, Yamaha's STAGEPAS Series Portable PA Systems are fast becoming the standard for musicians and other PA users on the go.

These combination mixer/amplifier/speaker systems are exceptionally lightweight, portable and full-featured. Since virtually everything you need is in one, easy-to-use package, you can be set up and playing within a matter of minutes. And when you're done, you can be packed and back on the road again with the same ease and speed. Yet despite the simplicity and compact size, these systems cut no corners in sound quality or versatility, and in fact give you some advanced features not normally found in systems of this class.

The series includes the single-speaker STAGEPAS 150M and 250M, which can be expanded to a stereo system by simply adding a second speaker. They can also function either as an ultra-portable PA system, or as a powerful keyboard amplifier—with sound quality and portability that far surpasses any other conventional keyboard amp. No matter what system you choose, you have a high-power, high-performance sound system ready for a wide variety of venues and events, both indoors and out.

All-in-one Systems

Virtually everything you need is right here in each of these systems: one versatile, powerful mixer/amplifier, two top-quality speakers (or one speaker, with the STAGEPAS 250M and 150M systems), and even the necessary speaker cables for quick setup!

Two-way Full-range Speaker System

The STAGEPAS delivers a remarkably large and powerful sound despite its compact size—thanks to the two-way speaker system and bass reflex design. All models feature a 1" titanium tweeter. The 250M and 500 employ a 10" woofer while the 150M and 300 have an 8" woofer. The sound is exceptionally clean, clear and free from break-up, even at high levels.

Detachable Powered Mixer

The high-performance combination mixer/amplifier comes in 8- and 10-channel configurations, providing all the inputs you need, as well as all the power you want. Fitting neatly inside one of the speaker cabinets, it can be used as is, or detached for convenient placement and easy access.



Optional BMS-10A for Convenient Mic Stand Mounting

The detachable mixer can be conveniently mounted on a conventional microphone stand for easy access, using the optional BMS-10A Mic Stand Adaptor.



Multi-purpose Portable PA

Whether your Portable PA needs are Pro Audio (for music performance) or Public Address for school, church and meeting assemblies, the STAGEPAS systems are lightweight, compact and simple to setup—and fit a wide variety of applications.

For Bands

Multiple microphone inputs make the STAGEPAS series an ideal choice for band rehearsals and performances. The STAGEPAS 500 in particular is well suited for many sources and larger venues, while the optional MSR Series powered speakers can be used for monitoring.



For Singers

Vocalists will appreciate the built-in, high-quality reverb on all STAGEPAS systems. Plus, the 250M and 500 models feature a built-in limiter/compressor to let you dial in a smooth, punchy vocal sound.

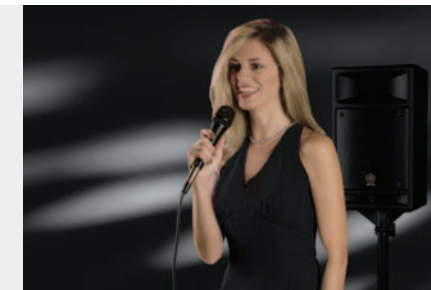

For Instrumentalists

The versatile STAGEPAS mixer has more than enough input capability to directly handle many different instruments—from electric-acoustic guitars to electronic keyboards.



For Keyboard Players

Players needing a simple, yet exceptionally high-quality keyboard amplifier will find ideal solutions in the STAGEPAS 150M and 250M. These compact, highly portable and easy-to-use systems can serve as your main system for small gigs, or as a sub-mixer for direct connection to the main mixer at large events.



For Guitarists

The STAGEPAS 150M and 250M are excellent systems for guitarists playing in small venues, since they deliver outstanding sound for the house as well as great monitor sound for the player.



For Public Speakers

If you're a speaker or giving presentations, you can instantly optimize the system settings with the special Speech mode—giving you maximum clarity for speech applications. Naturally, you can mix background music from a CD player or other source with the mic input.



STAGEPAS 500

10 Channels and 250W + 250W Power for More Sources and Larger Venues

Dual 250 Watt Class D Power Amplifier

Two 250 Watt power amplifier can fill surprisingly large clubs or rooms, or project your sound over a considerable distance outdoors. The class-D power amplifier has been painstakingly designed to deliver superior sound quality as well as reliability in a remarkably compact unit.

Versatile 10-channel Mixer with Monitor and Record Outputs

If there are more members in your band than the STAGEPAS 300's 8 input channels can handle, or you simply have a lot of sources to mix, the STAGEPAS 500 gives you 10 input channels in all: four mono microphone/line inputs and three stereo line inputs. The additional stereo channel can be used for either a stereo or mono source. In addition to the main speaker outputs the mixer has line outputs that can be used to connect additional powered speakers for monitoring, and to send the mixer's output to a recording device.

Phantom Power for High-performance Condenser Microphones

The STAGEPAS 500 mixer features switchable phantom power for the four mono microphone/line inputs. This lets you use high-performance phantom-powered condenser microphones in situations where you want the extended, natural response they provide.

Built-in Channel Compression/Limiting

Channels 1 and 2 feature LIMIT/COMP switches that let you apply either limiting or compression to those channels. Limiting is useful in preventing input overload and distortion with sources that suddenly surge in level, while compression can smooth out vocals, bass, guitar and other signals that have widely varying dynamic range, giving those sources added punch and helping them "sit" better in the mix.

Pole Mount Receptacle for Direct Speaker Stand Mounting

The STAGEPAS 500 speaker is directly mountable on 35mm pole with securing thumb screw.



Convenient Accessory Compartment

Neatly pack away your cables, microphones and other small necessities in the speaker accessory compartment, and enjoy a truly streamlined system when on the road.

Common Features

- Detachable Powered Mixer
- Two-way Full-range Speaker System
- Built-in EQ and High-quality Digital Reverb
- MUSIC / SPEECH Switch
- Auto Limiter
- LED Output Level Meter
- Ideal for Monitor Speaker Use
- Speaker Cables Supplied



Dimensions

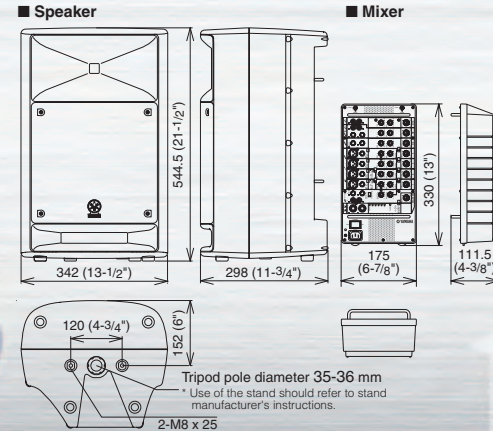

STAGEPAS 300

The Ultimate In Portability with 8 Channels and 150W + 150W Output

Dual 150 Watt Class D Power Amplifier

Two 150 Watt power amplifier is plenty for most small venues and street performance situations. And you get clean, reliable power from a Class-D design that provides high-efficiency amplification with low power consumption and minimal heat generation, allowing the amplifier to be built into a smaller, lighter, and cooler package.

8-channel Mixer with Monitor and Record Outputs

The powered mixer is normally stored in the rear of one of the speakers, but it can be easily detached (the only tool you need is a coin) for convenient operation. The STAGEPAS 300 mixer has a total of eight input channels: four mono microphone/line inputs and two stereo line inputs. In addition to speaker outputs for the supplied speakers, the mixer has line outputs that can be used to connect additional powered speakers for monitoring, and to send the mixer's output to a recording device.

Convenient Accessory Compartment

Neatly pack away your cables, microphones and other small necessities in the speaker accessory compartment, and enjoy a truly streamlined system when on the road.



Speaker Stand Mountable (with optional accessory)

The STAGEPAS 300 speakers can be mounted onto a standard speaker stands, using an optional mount adaptor such as the ADP138, the Ultimate BMB200, or an equivalent.

Common Features

- Detachable Powered Mixer
- Two-way Full-range Speaker System
- Built-in EQ and 1-bit Modulation Reverb
- MUSIC / SPEECH Switch
- Auto Limiter
- LED Output Level Meter
- Ideal for Monitor Speaker Use
- Speaker Cables Supplied



Dimensions

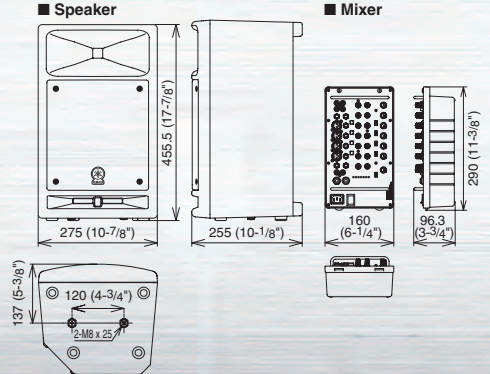

Useful Features for Bands

Phantom Power Switch

Supplies phantom power to the microphone inputs on channels 1 through 4, for high performance condenser microphones.

LIMIT / COMP Switches

Apply limiting or compression to channels 1 and 2 for added sonic control and versatility.



Digital Reverb Renowned Yamaha SPX reverb technology gives you studio-quality ambience on the road.

Live Performance with a Full Band

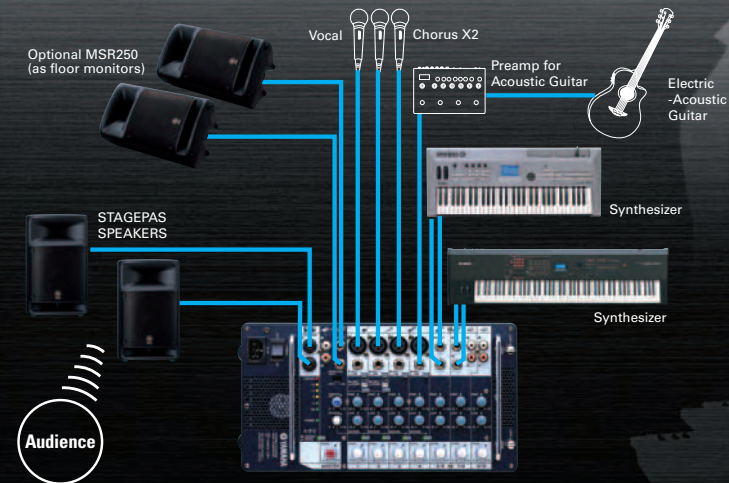

Useful Features for Performers

MUSIC / SPEECH Switch

This unique feature optimizes the system settings for maximum clarity with speech.



1-bit Modulation Reverb Advanced 1-bit modulation technology delivers great-sound reverb for natural warmth and ambience.

Duo Performers

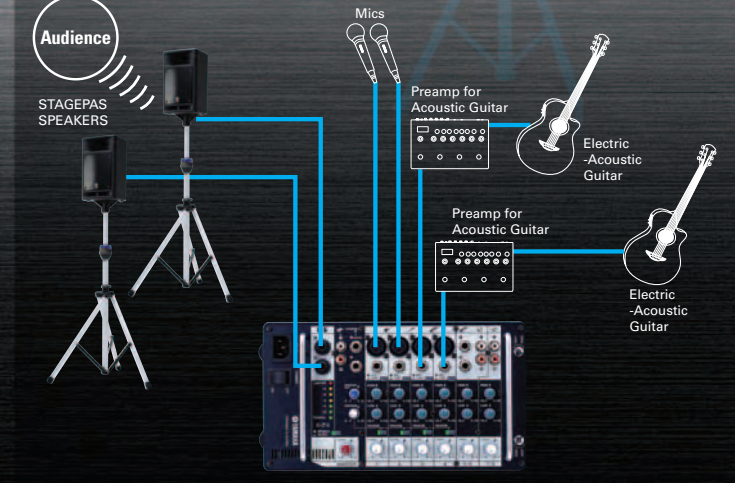

STAGEPAS 250M

10 Channels for More Sources, Plus 250 Watt of Power

Versatile 10-channel Powered Mixer

The built-in yet detachable mixer of the STAGEPAS 250M provides a total of ten input channels: two mono microphone/line inputs and four stereo line inputs. In addition to a speaker output for the supplied speaker, the mixer has line outputs that can be used to connect additional powered speakers or to send the mixer's output to a main mixer or recording device. It also features a convenient PHONES jack for connecting a set of headphones.

250 Watt Class D Power Amplifier

This high-power amplifier is capable of filling a relatively large club or room with sound, and can even project well outdoors. The advanced Class-D design delivers exceptional efficiency—ensuring high power amplification with low power consumption and minimal heat generation. This means you get superior sound quality and reliability in a remarkably compact unit.

Built-in Compression/Limiting

Channels 1 and 2 feature LIMIT/COMP switches that let you apply either limiting or compression to those channels. Limiting is useful in preventing input overload and distortion with sources that suddenly surge in level, while compression can smooth out vocals, bass, guitar and other signals that have widely varying dynamic range, giving those sources added punch and helping them "sit" better in the mix.

Phantom Power for High-performance Condenser Microphones

The STAGEPAS 250 mixer features switchable phantom power for the two mono microphone/line inputs. This lets you use high-performance phantom-powered condenser microphones in situations where you want the extended, natural response they provide.

Ideal for Monitor Speaker Use

The STAGEPAS 250M is also effective as a monitor speaker system (especially for keyboard players, drummers and solo performers), thanks to its full-range reproduction, convenient mixing controls, and versatile speaker placement.

Pole Mount Receptacle for Direct Speaker Stand Mounting

The STAGEPAS 250M speaker is directly mountable on 35mm pole with securing thumb screw.

Common Features

- Detachable Powered Mixer
- Two-way Full-range Speaker System
- Built-in EQ and High-quality Digital Reverb
- MUSIC / SPEECH Switch
- Auto Limiter
- LED Output Level Meter
- One Speaker Cable Supplied

Useful Features for Keyboard Players

Stereo Link Out

A dedicated Stereo Link Out jack is provided for connection to optional MSR250 powered speaker—allowing you to easily create a powerful stereo setup for larger venues and greater sound projection.

Balanced ST SUB OUT

These outputs let you connect additional powered speakers to the STAGEPAS 250M or send the mixer's output to a main mixer or recording device.



Click Assign Switches

This convenient feature lets you connect a drum machine, synthesizer or metronome to Channels 7/8 and route a click/metronome or rhythm signal through the mixer for monitoring purposes only. Turning this switch on takes the Channel 7/8 signal out of the ST SUB OUT jacks. A second Click switch lets you route the click signal to the PHONES out for headphones monitoring.

Small Gig with STAGEPAS 250M

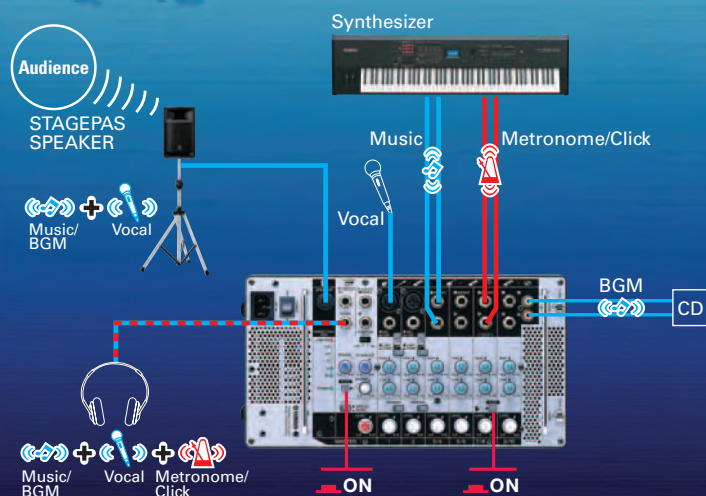

STAGEPAS 150M

Exceptionally Compact System —8 Channels, 150 Watt Output

Flexible 8-channel Powered Mixer

The STAGEPAS 150M provides a total of eight input channels: two mono microphone/line inputs and three stereo line inputs. Along with the output for the supplied speaker, the built-in yet detachable mixer also has line outputs that can be used to connect additional powered speakers or to send the mixer's output to a main mixer or recording device. A convenient PHONES jack is also included for connecting a set of headphones.

150 Watt Class D Power Amplifier

This power amplifier is all you'll need for most small venues and street performance situations, as well as personal monitoring applications. The advanced Class-D design delivers exceptional efficiency—ensuring high power amplification with low power consumption and minimal heat generation. This means you get superior sound quality and reliability in a remarkably compact unit.

Ideal for Monitor Speaker Use

The STAGEPAS 150M is also effective as a monitor speaker system (especially for keyboard players, drummers and solo performers), thanks to its full-range reproduction, convenient mixing controls, and versatile speaker placement.

Speaker Stand Mountable (with optional accessory)

The STAGEPAS 150M speaker can be mounted onto a standard speaker stand, using an optional mount adaptor such as the ADP138, the Ultimate BMB200, or an equivalent.

Common Features

- Detachable Powered Mixer
- Two-way Full-range Speaker System
- Built-in EQ and 1-bit Modulation Reverb
- MUSIC / SPEECH Switch
- Auto Limiter
- LED Output Level Meter
- One Speaker Cable Supplied

Useful Features for Keyboard Players

Stereo Link Out

A dedicated Stereo Link Out jack is provided for connection to optional MSR100 powered speaker—allowing you to easily create a powerful stereo setup for larger venues and greater sound projection.

Balanced ST SUB OUT

These outputs let you connect additional powered speakers to the STAGEPAS 150M or send the mixer's output to a main mixer or recording device.



Click Assign Switches

This convenient feature lets you connect a drum machine, synthesizer or metronome to Channels 5/6 and route a click/metronome or rhythm signal through the mixer for monitoring purposes only. Turning this switch on takes the Channel 5/6 signal out of the ST SUB OUT jacks. A second Click switch lets you route the click signal to the PHONES out for headphones monitoring.

Complete PA and Monitoring System with STAGEPAS 150M

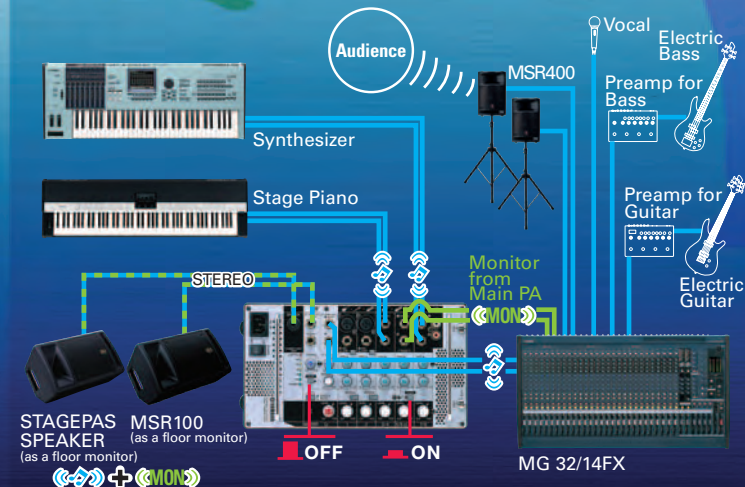

Dimensions Unit: mm (inch)

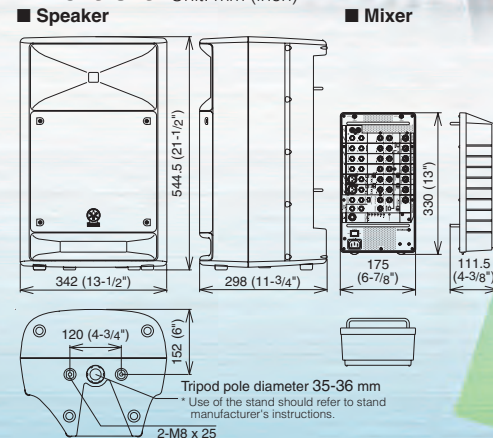

Dimensions Unit: mm (inch)

