



MUSIC SYNTHESIZER  
SYNTHÉTISEUR MUSICAL  
SINTETIZADOR MUSICAL

**MODX MS**

**MODX M7**

**MODX MS**

---

**Quick Guide**  
**Guide rapide**  
**Guía rápida**

English

Français

Español

EN  
FR  
ES

## FCC INFORMATION (U.S.A.)

### 1. IMPORTANT NOTICE: DO NOT MODIFY THIS UNIT!

This product, when installed as indicated in the instructions contained in this manual, meets FCC requirements. Modifications not expressly approved by Yamaha may void your authority, granted by the FCC, to use the product.

### 2. IMPORTANT:

When connecting this product to accessories and/or another product use only high quality shielded cables. Cable/s supplied with this product MUST be used. Follow all installation instructions. Failure to follow instructions could void your FCC authorization to use this product in the USA.

### 3. NOTE:

This product has been tested and found to comply with the requirements listed in FCC Regulations, Part 15 for Class "B" digital devices. Compliance with these requirements provides a reasonable level of assurance that your use of this product in a residential environment will not result in harmful interference with other electronic devices. This equipment generates/uses radio frequencies and, if not installed and used according to the instructions found in the users manual, may cause interference harmful to the operation of other electronic devices. Compliance with FCC regulations does not guarantee that interference will not occur in all installations. If this product is found to be the source of interference, which can be determined by turning the unit "OFF" and "ON", please try to eliminate the problem by using one of the following measures:

- Relocate either this product or the device that is being affected by the interference.
- Utilize power outlets that are on different branch (circuit breaker or fuse) circuits or install AC line filter/s.
- In the case of radio or TV interference, relocate/reorient the antenna. If the antenna lead-in is 300 ohm ribbon lead, change the lead-in to co-axial type cable.

If these corrective measures do not produce satisfactory results, please contact the local retailer authorized to distribute this type of product. If you cannot locate the appropriate retailer, please contact Yamaha Corporation of America, 6600 Orangethorpe Avenue, Buena Park, CA 90620, U.S.A.

The above statements apply ONLY to those products distributed by Yamaha Corporation of America or its subsidiaries.

(529-M04 FCC class B YCA 02)

## COMPLIANCE INFORMATION STATEMENT (Supplier's declaration of conformity procedure)

Responsible Party: Yamaha Corporation of America

Address: 6600 Orangethorpe Avenue, Buena Park, CA 90620, U.S.A.

Telephone: 714-522-9011

Type of Equipment: Music Synthesizer

Model Name: MODX M6, MODX M7, MODX M8

This device complies with Part 15 of the FCC Rules.

Operation is subject to the following two conditions:

- 1) this device may not cause harmful interference, and
- 2) this device must accept any interference received, including interference that may cause undesired operation.

(529-M02 FCC sdoc YCA 02)

The model number, serial number, power requirements, etc., may be found on or near the name plate, which is at the bottom of the unit. You should note this serial number in the space provided below and retain this manual as a permanent record of your purchase to aid identification in the event of theft.

**Model No.**

---

**Serial No.**

---

(1003-M06 plate bottom en 01)

### Information for users on collection and disposal of old equipment:



This symbol on the products, packaging, and/or accompanying documents means that used electrical and electronic products should not be mixed with general household waste. For proper treatment, recovery and recycling of old products, please take them to applicable collection points, in accordance with your national legislation.

By disposing of these products correctly, you will help to save valuable resources and prevent any potential negative effects on human health and the environment which could otherwise arise from inappropriate waste handling.

For more information about collection and recycling of old products, please contact your local municipality, your waste disposal service or the point of sale where you purchased the items.

#### **For business users in the European Union:**

If you wish to discard electrical and electronic equipment, please contact your dealer or supplier for further information.

#### **Information on Disposal in other Countries outside the European Union:**

This symbol is only valid in the European Union. If you wish to discard these items, please contact your local authorities or dealer and ask for the correct method of disposal.

(58-M02 WEEE en 01)

Product Information Brochure (As per Rule 11(1A) (b) of the Plastic Waste Management Rules, 2016, as amended)

Brand Owner: Yamaha Music India Pvt. Ltd.

Registration Number: BO-10-000-11-AAACY3314N-23 and IM-19-000-07-AAACY3314N-24

(154-M01 IN pwmr 01)

# PRECAUTIONS

## PLEASE READ CAREFULLY BEFORE PROCEEDING

Please keep this manual in a safe and handy place for future reference.

### **WARNING**

Always follow the basic precautions listed below to avoid the possibility of serious injury or even death from electrical shock, short-circuiting, damages, fire or other hazards. These precautions include, but are not limited to, the following:

#### **Power supply**

- Do not place the power cord near heat sources such as heaters or radiators. Also, do not excessively bend or otherwise damage the cord, or place heavy objects on it.
- Do not touch the product or the power plug during an electrical storm.
- Use only the correct voltage specified for the product. The required voltage is printed on the name plate of the product.
- Use only the supplied AC adaptor (page 45) /power cord. Do not use the AC adaptor/power cord for other devices.
- Check the power plug periodically and remove any dirt or dust which may have accumulated on it.
- Insert the power plug firmly all the way into the AC outlet. Using the product when it is not plugged in sufficiently can cause dust to accumulate on the plug, possibly resulting in fire or skin burns.
- When setting up the product, make sure that the AC outlet you are using is easily accessible. If some trouble or malfunction occurs, immediately turn off the power switch and disconnect the plug from the outlet. Even when the power switch is turned off, as long as the power cord is not unplugged from the wall AC outlet, the product will not be disconnected from the power source.
- Do not connect the product to an electrical outlet using a multi-plug outlet extender. Doing so can result in lower sound quality, or possibly cause overheating in the outlet.
- When disconnecting the power plug, always hold the plug itself and not the cord. Pulling by the cord can damage it and cause electric shocks or a fire.
- If not using the product for long periods of time, be sure to pull the power plug from the AC outlet.

#### **Do not disassemble**

- This product contains no user-serviceable parts. Do not attempt to disassemble the internal parts or modify them in any way.

#### **Water warning**

- Do not expose the product to rain, use it near water or in damp or wet conditions, or place on it any containers (such as vases, bottles or glasses) containing liquids which might spill into any openings or places where water may drop. A liquid such as water getting into the product may cause a fire, electric shocks, or malfunctions.
- Use the AC adaptor indoors only. Do not use in any wet environments.
- Never insert or remove a power plug with wet hands.

#### **Fire warning**

- Do not place any burning items or open flames near the product, since they may cause a fire.

#### **If you notice any abnormality**

- If any of the following problems occur, immediately turn off the power switch and disconnect the power plug from the outlet.  
Finally have the device inspected by Yamaha service personnel.
  - The power cord or plug becomes frayed or damaged.
  - Unusual smells or smoke are emitted.
  - Some object, or water has been dropped into the product.
  - There is a sudden loss of sound during use of the product.
  - Cracks or other visible damage appear on the product.

## CAUTION

Always follow the basic precautions listed below to avoid the possibility of physical injury to you or others, or damage to the product or other property. These precautions include, but are not limited to, the following:

### Location

- Do not place the product in an unstable position or a location with excessive vibration, where it might accidentally fall over and cause injury.
- Before moving the product, remove all connected cables, to prevent damage to the cables or injury to anyone who might trip over them.

### Connections

- Before connecting the product to other devices, turn off the power for all devices. Before turning the power on or off for all devices, set all volume levels to minimum.
- Be sure to set the volumes of all devices at their minimum levels and gradually raise the volume controls while playing the product to set the desired listening level.

### Handling

- Do not insert foreign materials such as metal or paper into any openings or gaps of the product. Failure to observe this may cause a fire, electric shocks, or malfunctions.
- Do not rest your weight on, or place heavy objects on the product, and do not use excessive force on the buttons, switches or connectors.
- Do not use the product or headphones for a long period of time at a high or uncomfortable volume level, since this can cause permanent hearing loss. If you experience any hearing loss or ringing in the ears, consult a physician.
- Remove the power plug from the AC outlet before cleaning the unit. Failure to observe this may cause electric shocks.

Yamaha cannot be held responsible for damage caused by improper use or modifications to the product, or data that is lost or destroyed.

Always turn the power off when the product is not in use.

Even when the [⏻] (Standby/On) switch is in standby status (display is off), electricity is still flowing to the product at the minimum level.

When you are not using the product for a long time, make sure you unplug the power cord from the wall AC outlet.

(DMI-11)

# NOTICE

To avoid the possibility of malfunction/ damage to the product, damage to data, or damage to other property, follow the notices below.

## ■ Handling

- Do not use this product in the vicinity of a TV, radio, stereo equipment, mobile phone, or other electric devices. Otherwise, this product, or the other device may generate noise.
- When you use the product along with an app on your smart device, such as a smartphone or tablet, we recommend that you enable "Airplane Mode" on the device to avoid noise caused by communication.
- Do not expose the product to excessive dust or vibrations, or extreme cold or heat (such as in direct sunlight, near a heater, or in a car during the day) to prevent the possibility of disfiguration, damage to the internal components or unstable operation.
- Do not place vinyl, plastic or rubber objects on the product, since this might discolor the product.

## ■ Maintenance

- When cleaning the product, use a soft and dry/slightly damp cloth. Do not use paint thinners, solvents, alcohol, cleaning fluids, or chemical-impregnated wiping cloths.

## ■ Saving data

- Edited Performance  
Edited Performance is lost when you turn off the power to the product without storing it. This also occurs when the power is turned off by the Auto Power Off function (page 11).
- Other settings  
Other settings are retained when the power is turned off.
- To save important settings  
Keep in mind that Performances and other settings saved to the product may occasionally be lost due to some failure, an operation mistake, etc. For this reason, you should save your important settings onto a USB flash drive (refer to the Operation Manual). Before using a USB flash drive, make sure to see page 12.

# Information

## ■ About copyrights

The copyright of the "content"<sup>\*1</sup> installed in this product belongs to Yamaha Corporation or its copyright holder. Except as permitted by copyright laws and other relevant laws, such as copying for personal use, it is prohibited to "reproduce or divert"<sup>\*2</sup> without the permission of the copyright holder. When using the content, consult with a copyright expert.

If you create music or perform with the contents through the original use of the product, and then record and distribute them, the permission of Yamaha Corporation is not required regardless of whether the distribution method is paid or free of charge.

\*1: The word "content" includes a computer program, audio data, Accompaniment Style data, MIDI data, waveform data, voice recording data, music score, and score data, etc.

\*2: The phrase "reproduce or divert" includes taking out the content itself in this product, or recording and distributing it without changes in a similar manner.

## ■ About this manual

- The illustrations and LCD screens as shown in this manual are for instructional purposes only.
- Unless indicated otherwise, the illustrations and screens as shown in this manual are based on the MODX M6 (in English).
- The company names and product names in this manual are the trademarks or registered trademarks of their respective companies.

## ■ About disposal

When disposing of this product, please contact the appropriate local authorities.

# MEMO



# Welcome

Thank you for purchasing this Yamaha Music Synthesizer!

This instrument inherits the innovative sonic expressive capabilities created by the flagship synthesizer MONTAGE M, yet is slim, lightweight, and easy to carry. We recommend that you read this manual carefully so that you can fully take advantage of the advanced and convenient functions of this instrument. We also recommend that you keep this manual in a safe and handy place for future reference.

## About the manuals

The set of documents listed below are included with this instrument.

### Printed manual included with this product

---

#### ■ Quick Guide (this book)

Provides explanations for the basic functions of the instrument.

### Website-based manuals

---

The manuals provided on the website can be downloaded from the Yamaha Downloads. Connect to the Internet and enter the model name "MODX M" in the Model Name or Keyword search box and click Search.



**Yamaha Downloads**

<https://download.yamaha.com/>

#### ■ Operation Manual (.pdf)

Provides instructions on operating the instrument, as well as detailed information on the internal structure and connection of other instruments and devices.

#### ■ Data List (.xlsx and .pdf)

This file contains various important lists such as the Performance list, Effect type list, Waveform list, Arpeggio type list, and MIDI implementation chart.

## Included accessories

- AC adaptor PA-300C\* ×1
- Quick guide (this book) ×1
- *Cubase AI Download Information* ×1
- *Expanded Softsynth Plugin for MONTAGE M/MODX M Download Information* ×1
- About downloading manuals ×1
- Welcome card ×1

\* May not be included depending on your area. Check with your Yamaha dealer.

## About firmware updates

To implement new functions and improve operability, this instrument may be shipped with an updated version of the firmware installed.

The manual for the updated version of the firmware can be downloaded from the website below.

**Yamaha Downloads:** <https://download.yamaha.com/>

The firmware version of your keyboard can be checked via [UTILITY] → *Settings* → *System*.

## Notation in this document

### Model name

In this document, MODX M6, MODX M7, and MODX M8 are collectively called the “MODX M.”

### NOTE

"NOTE" indicates supplementary descriptions.

# Contents

<b>PRECAUTIONS</b> .....	<b>2</b>
<b>NOTICE</b> .....	<b>4</b>
<b>Information</b> .....	<b>4</b>
<b>Welcome</b> .....	<b>6</b>
<b>About the manuals</b> .....	<b>6</b>
Printed manual included with this product .....	6
Website-based manuals .....	6
<b>Included accessories</b> .....	<b>6</b>
<b>About firmware updates</b> .....	<b>7</b>
<b>Notation in this document</b> .....	<b>7</b>
<b>Features</b> .....	<b>9</b>
What is the <i>Motion Control Synthesis Engine</i> ? .....	9
Compact design for convenient portability and enhanced operability .....	9
<b>Setting up</b> .....	<b>10</b>
Power supply .....	10
Connecting speakers or headphones .....	10
Turning the instrument ON/OFF .....	11
Auto Power Off function .....	11
Adjusting the master volume .....	12
Using USB flash drives .....	12
<b>Preparation for live performance</b> .....	<b>13</b>
<b>Basic Performance structure</b> .....	<b>14</b>
<b>How Live Set works</b> .....	<b>15</b>
Live Set bank .....	15
<b>Panel controls and functions</b> .....	<b>16</b>
Top panel .....	16
Rear panel .....	30
<b>Status check and basic operation</b> .....	<b>34</b>
Checking the status .....	34
Opening setting screens .....	38
Moving the cursor and changing parameter values .....	39
Icons shown for specific operations .....	40
Entering characters and numbers .....	41
<b>Playing the keyboard</b> .....	<b>43</b>
Selecting a Performance from the <i>Live Set</i> screen .....	43
<b>Troubleshooting</b> .....	<b>44</b>
Restoring the factory default settings ( <i>Initialize All Data</i> ) .....	44
<b>Specifications</b> .....	<b>45</b>
<b>Index</b> .....	<b>46</b>
<b>Note on source code distribution</b> .....	<b>47</b>

# Features

The MODX M synthesizers feature the built-in *Motion Control Synthesis Engine*, letting you create enormously complex, multi-textured sounds by combining AWM2, FM-X, and AN-X synthesis engines seamlessly and further modifying the sound using Motion control. Therefore, you can use the MODX M, not just for recreating conventional sounds, but also for creating completely new sounds.

## What is the *Motion Control Synthesis Engine*?

This is a powerfully comprehensive synthesis system that uses a hybrid, multi-tone-generator sound engine, and sophisticated motion controls with multiple control sources for creating complex and continuously shifting sonic textures.

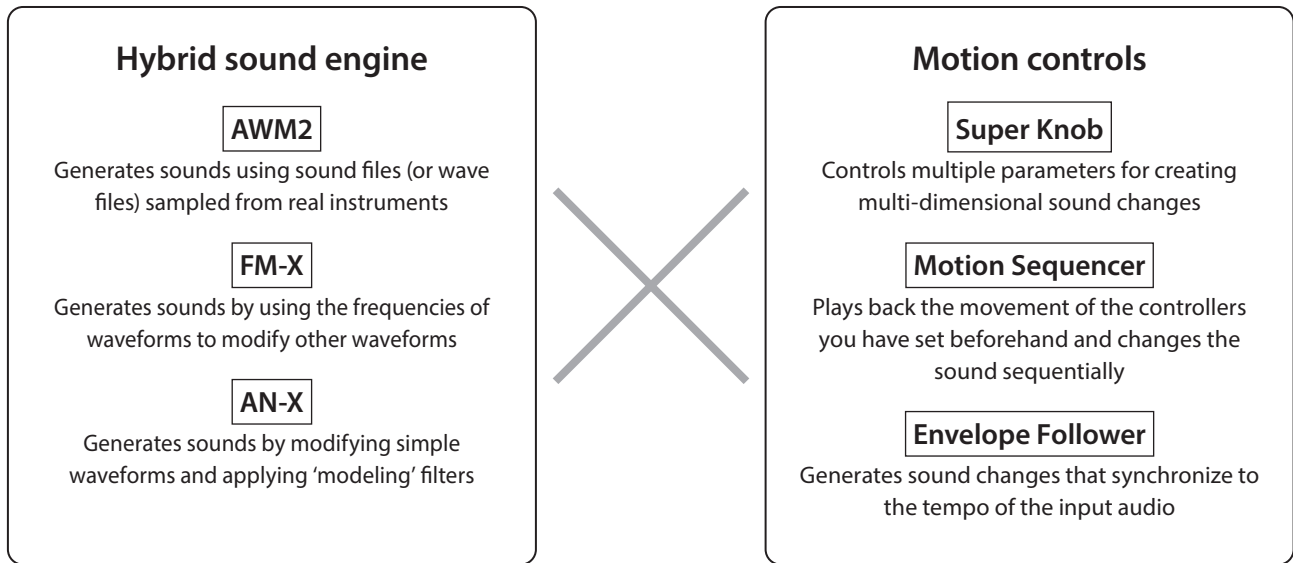

## Compact design for convenient portability and enhanced operability

The MODX M is compact in both size and weight, making it convenient and easy to carry.

The high-quality keyboard provides an authentic playing experience, and the precision control knobs allow for fine expression, expanding the range of your performance.

# Setting up

## Power supply

1. Make sure the [⏻] (Standby/On) switch on the instrument is set to the Standby (■) position.
2. Connect the supplied power cord and AC adaptor.
3. Fasten the DC plug cord inside the cable clip next to the DC IN jack as shown below, and then connect the DC plug to the DC IN jack.

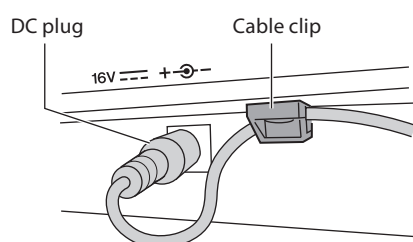

### NOTICE

Use of the cable clip prevents accidental unplugging of the cable during operation. Make sure to avoid pulling on the cord strongly while the DC plug is set to the cable clip to prevent wear on the cord or possible breakage of the clip.

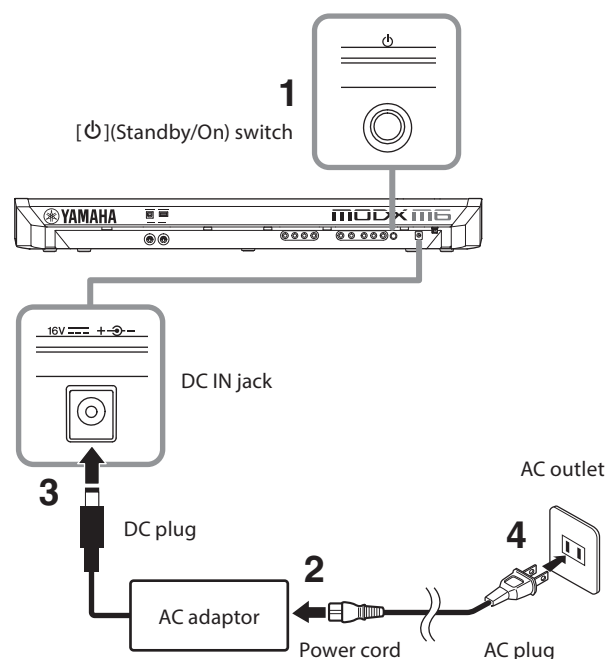

The shapes of the plug and outlet may differ depending on your locale.

4. Connect the AC plug to the AC outlet.



### WARNING

- Use the supplied AC adaptor (page 45)/power cord only. Do not use the AC adaptor/power cord for other devices. Using the wrong AC adaptor/power cord can result in damage to the instrument or overheating.
- When setting up the product, make sure that the AC outlet you are using is easily accessible. If some trouble or malfunction occurs, immediately turn the power off and disconnect the plug from the outlet.

### NOTE

When disconnecting the power cord/AC adaptor, first turn off the power, and then follow the steps above in reverse order.

## Connecting speakers or headphones

Since this instrument has no built-in speakers, you will need to monitor the sound of the instrument by using external equipment. Make sure to turn off any keyboard amplifiers, monitor speakers, and other devices, and then connect a set of headphones and any other devices as shown below. When making connections, be sure that your cables have the appropriate ratings.

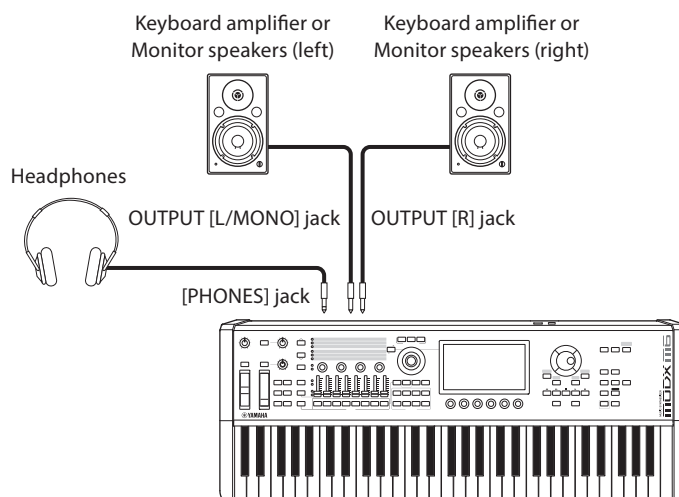

## Turning the instrument ON/OFF

Before turning the power on and off, make sure that the volume settings for the instrument and any external devices such as powered speakers are set to their minimum, and then operate them in the following order.

### ■ When turning the power on

First, the instrument (displays will turn on and buttons will light), and then the connected powered speakers.

### ■ When turning the power off

First, the connected powered speakers, and then the instrument (displays will turn off and buttons will turn off).

Keep in mind that the [⏻] (Standby/On) switch is located at the right side (from the view of the keyboard) of the DC IN jack on the rear panel of the instrument.



#### WARNING

Even when the [⏻] (Standby/On) switch is in standby status, electricity is still flowing to the product at the minimum level. Remove the electric plug from the outlet when the instrument is not to be used for extended periods of time, or during electrical storms.

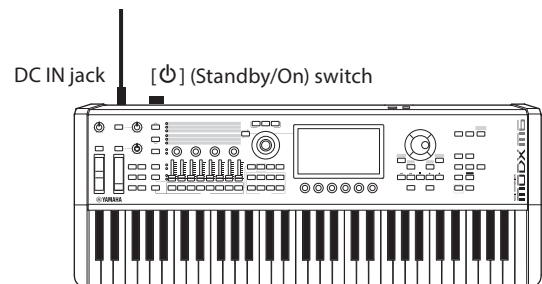

## Auto Power Off function

To prevent unnecessary power consumption, this instrument features an Auto Power Off function that automatically turns the power off if the instrument is not operated for a specific period of time.

### ■ Auto Power Off function setting

You can enable the Auto Power Off function and select the time setting for activating the function.

Procedure	[UTILITY] → Settings → Advanced → Auto Power Off
Settings (in minutes)	Off (Auto Power Off disabled), 5, 10, 15, 30, 60, 120
Default	Off (Auto Power Off disabled)

### ■ Disabling Auto Power Off function (simple method)

Turn the power on while holding down the lowest key on the keyboard. An "Auto power off disabled. Energy consumption might increase." message appears briefly on the screen and Auto Power Off is disabled. The setting is retained even if the power is turned off.

#### NOTICE

The setting will revert to its default value if not backed up before the power is turned off.

- When the instrument is not operated for a specified period of time while connected to an external device such as an amplifier, speaker or computer, make sure to follow the instructions in this Quick Guide to turn off the power to the instrument and the connected devices in the proper sequence to protect the devices from damage. If you do not want the power to turn off automatically when a device is connected, disable Auto Power Off function.
- When Auto Power Off function is set to **Off**, the value will be retained even if the backup data saved on another device is loaded to the instrument. When Auto Power Off function is set to something other than **Off**, the value will be overwritten with loaded data.

#### NOTE

- The setting time is approximate.
- To turn the power on after Auto Power Off function has been executed, press the [⏻] (Standby/On) switch to set the switch to the Standby (■) position and press it again to turn it On (■).
- When the factory settings are restored, the setting time is changed to the default value (Off).

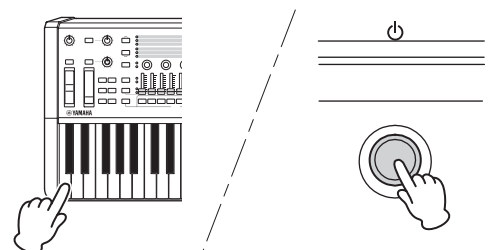

## Adjusting the master volume

---

Adjust the overall level of this instrument by using the [MASTER VOLUME] knob.

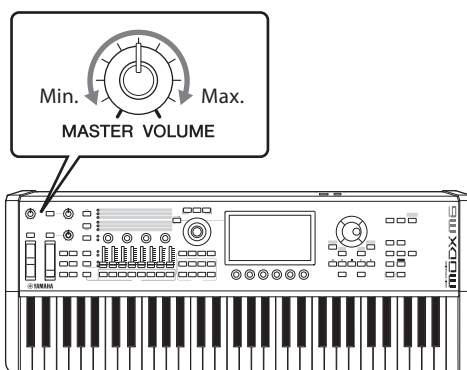

### CAUTION

Do not listen over the headphones at high volume for long periods of time. Doing so may cause hearing loss.

## Using USB flash drives

---

By connecting a USB flash drive to a USB [TO DEVICE] terminal, you can save your custom data to the connected drive, as well as read data from it. Before using the USB flash drive, be sure to read "Precautions when using the USB [TO DEVICE] terminal" on page 31.

### ■ Formatting a USB flash drive

You should format the USB flash drive only on this instrument. A USB flash drive formatted on another device may not operate properly.

#### NOTICE

The format operation overwrites any previously existing data. Make sure that the USB flash drive you are formatting does not contain important data.

#### NOTE

For more information on how to format the USB flash drive, refer to the Operation Manual.

### ■ To protect your data (write-protect)

To prevent important data from being inadvertently erased, enable write protection for the USB flash drive. If you are saving data to the USB flash drive, make sure to disable write protection.

### ■ Turning off the instrument

When turning off the instrument, make sure that the instrument is NOT accessing the USB flash drive by playback, recording or file management.

# Preparation for live performance

Shown below is a possible way for preparing the MODX M for use in live performance situations.

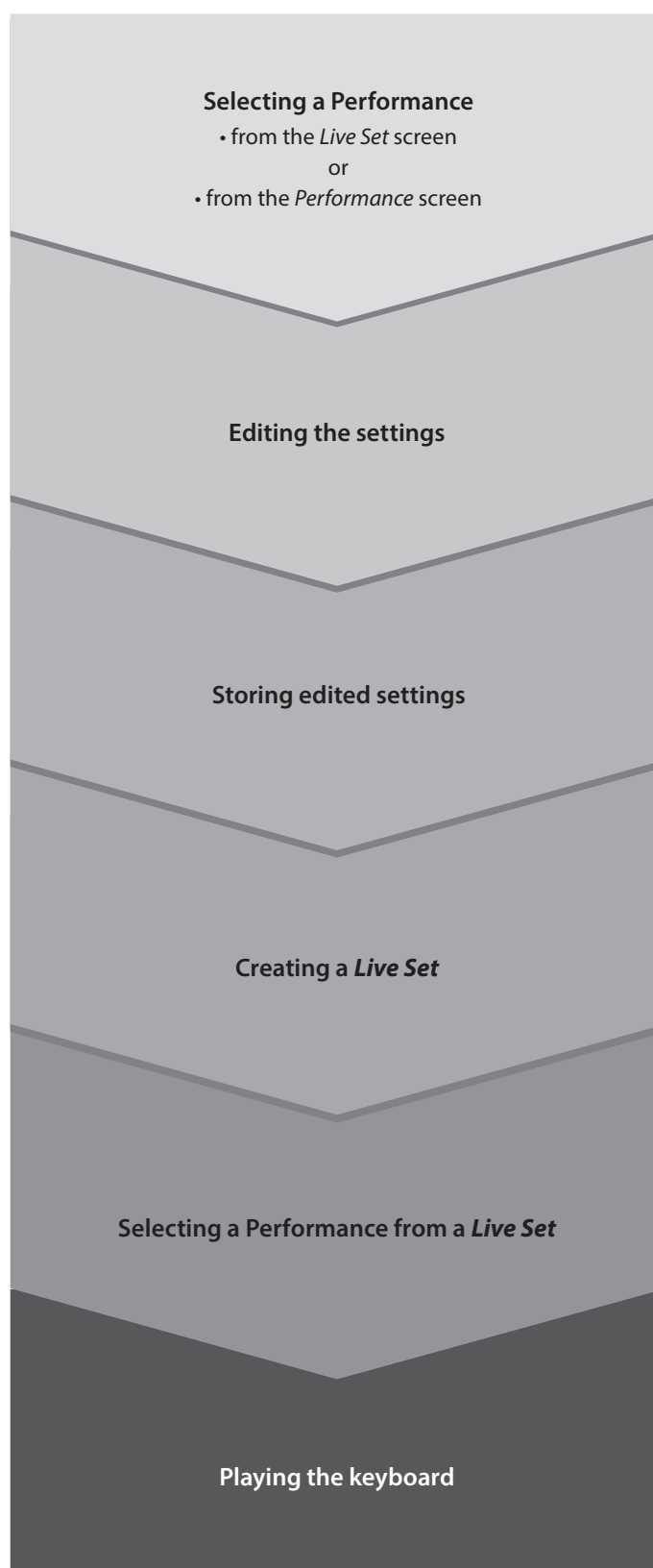

# Basic Performance structure

On the MODX M, the group of settings related to a specific sound is called a “Performance.” Select the desired Performance and play the keyboard.

A Performance can consist of up to 16 Parts, with a sound assigned to each Part.

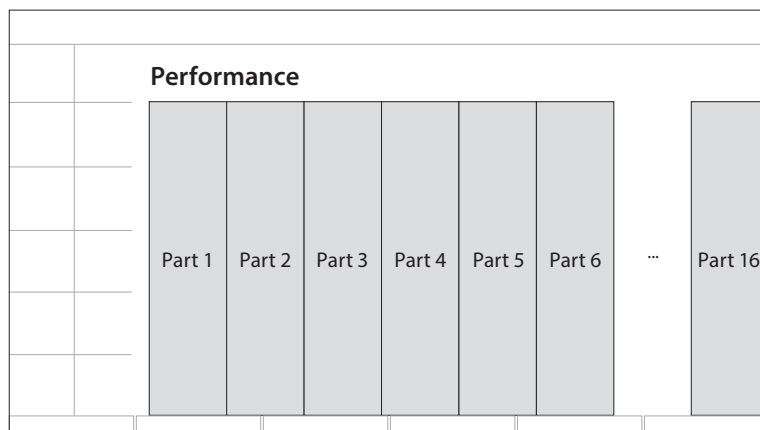

A Performance that contains multiple Parts is called a Multi-Part Performance, while a Performance that contains only one Part is called a Single-Part Performance. Single-Part Performances can be used in the same way as Voices on AWM2 synthesizers.

There are four types of Parts.

## ■ Normal Parts (AWM2)

Parts played by the AWM2 sound engine. An instrument sound such as piano, organ, guitar, and synthesizer can be assigned to a Part.

## ■ Normal Parts (FM-X)

Parts played by the FM-X sound engine.

## ■ Normal Parts (AN-X)

Parts played by the AN-X sound engine.

## ■ Drum Parts (AWM2)

Parts played by the AWM2 sound engine. A percussion instrument sound can be assigned to the Part. The Drum Parts are used for playing rhythms.

## NOTE

- If you wish to create sounds by using default initial values, select an *Init* Performance.
- If you wish to use this instrument as a 16-part multitimbral tone generator, use the *Multi/GM* Performances. These are Performances using all 16 parts, with the drums being assigned to Part 10.

Performances allow you to select a sound for each Part and combine multiple Parts in sophisticated split and layer settings for playing on the keyboard. Moreover, you can create complex sounds by editing the Performances and Parts from the Edit screen and enabling the Motion Control settings.

The created Performance can be saved to internal memory, or to USB flash drives connected to the instrument. You can also use *Soundmondo*, a sound management and sharing service, to save backups for yourself or share your Performances with others.

**Soundmondo:** <https://www.yamaha.com/2/soundmondo>

By pairing the *Expanded Softsynth Plugin for MONTAGE M/MODX M* (the software version of the MONTAGE M/MODX M) installed on the computer with the hardware version of the MODX M, you can create and manage a greater number of Performances. The sounds you have used in your DAW for music production and the sounds you have used for live performance are shared between the software and hardware synthesizers.

# How Live Set works

MODX M series synthesizers feature a powerful *Live Set* function for saving and managing the Performances you've created. The *Live Set* function lets you register the desired MIDI and audio files to play along with the Performances you wish to use on stage. On the *Live Set* screen, there are 16 slots per page for saving up to 16 sets of settings. For example, you can register the same Performance with different volume settings to various slots so that you can change the volume of the Performance as the song progresses. That way you can simply tap the slot to switch to the next volume setting as you play live.

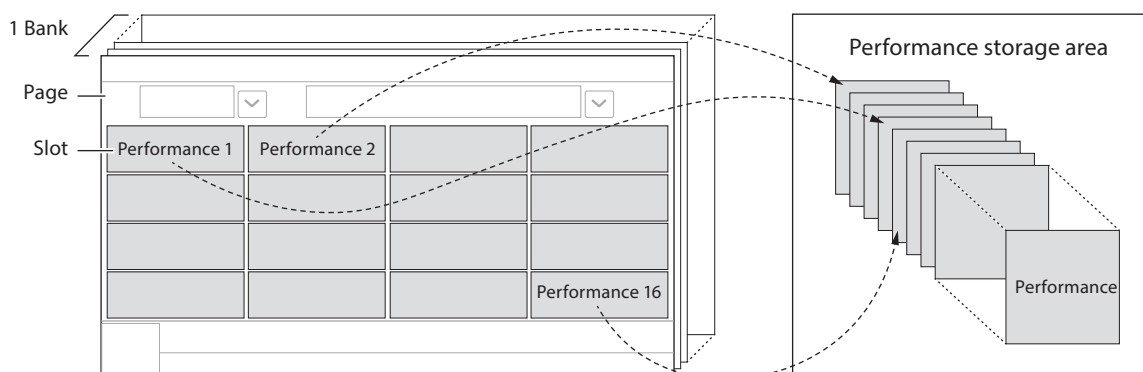

## NOTE

A link to the selected Performance is saved to each slot. When a Performance is edited and stored, all slots that have the link to the corresponding Performance will be updated.

## Live Set bank

A bank is a set of *Live Set* pages used for managing Performances. Each bank has 16 pages of *Live Sets*. There are three types of banks: Preset, User, and Library.

### ■ Preset bank

This is the location to which the built-in Performances (Preset Performances) are registered.

Any Performances in the Preset bank you have edited cannot be saved back to the Preset bank; they must be saved to a User bank.

## NOTE

Refer to the "Data list" for the list of Preset Performances.

### ■ User bank

This is the location for registered Performances you've edited yourself. Nothing is contained in this bank when the MODX M is shipped from the factory.

There are eight banks (or 128 pages) available, allowing you to register up to 2,048 Performances.

You can arrange the Performances in your own custom order—for example, according to a setlist in live performance situations.

### ■ Library bank

This is the location for registered Performances from the Library files. Nothing is contained in this bank when the MODX M is shipped from the factory.

You can register one Library file per bank.

Library files can be downloaded from the Yamaha website.

When you first start up the MODX M, the *Live Set* screen for the Preset bank will be shown on the LCD. The start-up screen can be set to a *Live Set* or *Performance* screen as desired ([UTILITY] → System).

# Panel controls and functions

This section provides an overview of the panel controls and functions.

## Top panel

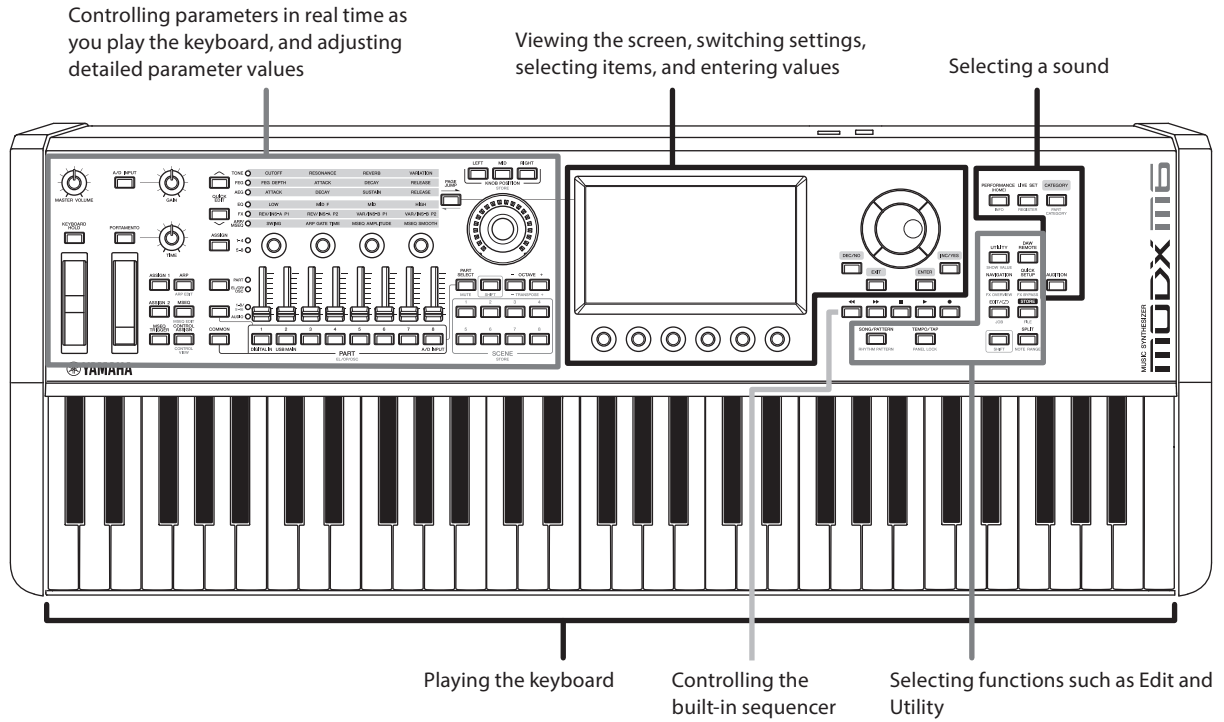

## Selecting a sound

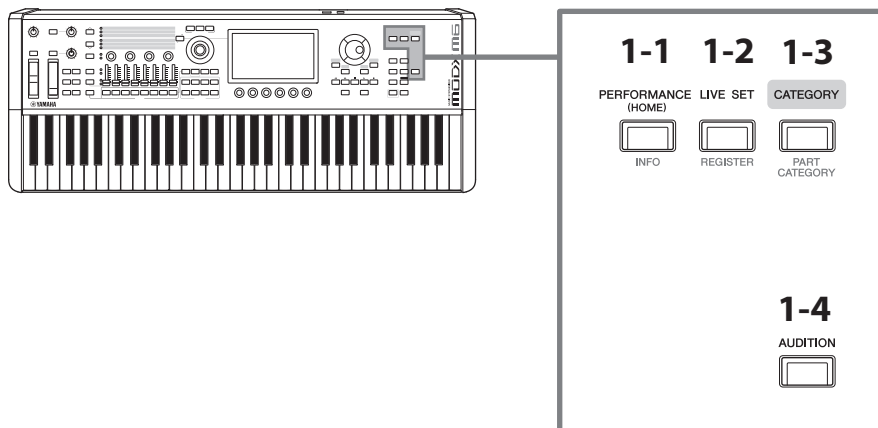

### 1-1 [PERFORMANCE (HOME)] button (INFO)

This calls up the *Performance* screen. You can switch to different Performance views by pressing this button repeatedly.

In the *Performance* screen, pressing the [PERFORMANCE (HOME)] button while holding down the [SHIFT] button calls up the screen for checking relevant information for the Performance (INFO screen).

### 1-2 [LIVE SET] button (REGISTER)

This calls up the *Live Set* screen. You can select a different Performance bank by pressing the button again.

Press the [LIVE SET] button and then tap the slot on the touchscreen to select a slot from the *Live Set* page currently shown on the screen.

Pressing [LIVE SET] button while holding the [SHIFT] button opens the screen for registering the current Performance to the *Live Set* page. Doing this beforehand allows you to call up Performances quickly and conveniently as you play live.

### 1-3 [CATEGORY] button (PART CATEGORY)

Use this button to call up the *Category Search* function. Every time you press the button, the next Performance bank is selected.

While the *Performance* screen is active, pressing [CATEGORY] button opens the *Performance Category Search* screen for selecting a Performance.

When the cursor is on a Part, pressing [CATEGORY] button while holding down the [SHIFT] button opens the *Part Category Search* screen.

### 1-4 [AUDITION] button

While one of the *Performance*, *Live Set*, or *Category Search* screens are shown, pressing [AUDITION] button starts or stops the playback of the audition phrase that uses the currently selected Performance.

## Selecting functions such as Edit and Utility

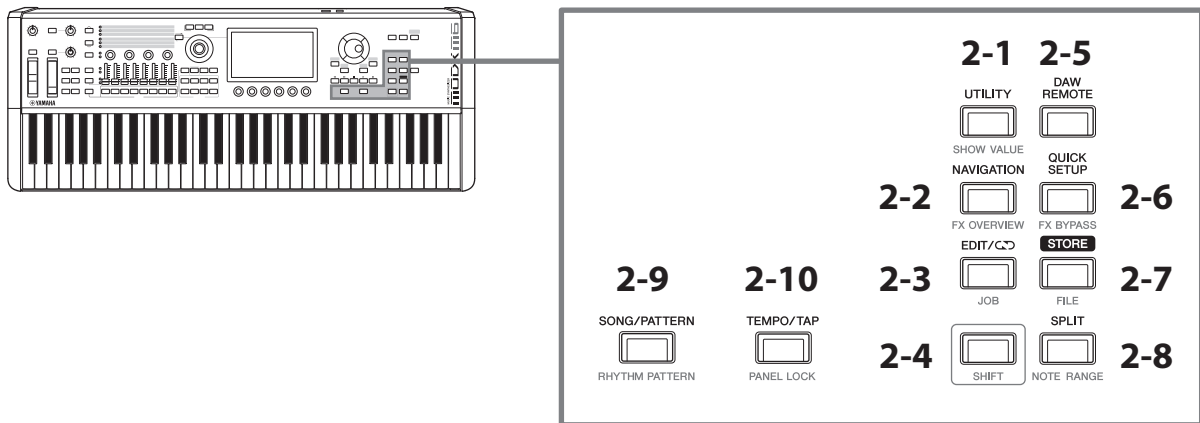

### 2-1 [UTILITY] button (SHOW VALUE)

This calls up the *Utility* screen where you can change the overall settings for the MODX M.

Pressing the [UTILITY] button while holding down the [SHIFT] button shows the values on the LCD if there are any values not shown graphically.

### 2-2 [NAVIGATION] button (FX OVERVIEW)

According to the Part you are editing, this calls up the map of the corresponding parameters. When you select one item from the map, the parameter setting screen for that item will be shown on the LCD.

Pressing [NAVIGATION] button while holding down the [SHIFT] button calls up the screen for checking the effect overview (FX OVERVIEW screen).

### 2-3 [EDIT/COPY] button (JOB)

This calls up the *Performance Edit*, *Live Set Edit* or *Pattern Edit* screen.

While editing the Performance parameters, pressing this button allows you to use the Compare function.

With the Compare function, you can check the sound before and after editing to see how the sound changes.

While the Edit screen is shown, press the [EDIT/COPY] button. The [EDIT/COPY] button flashes, and the settings temporarily revert to the state before the edit. Press the [EDIT/COPY] button again to enable the newly edited settings again.

Pressing [EDIT/COPY] button while holding down the [SHIFT] button calls up the screen for Job settings (JOB screen).

### 2-4 [SHIFT] button

While holding down [SHIFT] button, pressing another button enables you to call up the alternate function printed in red at the bottom of each button.

For the list of functions, refer to the Operation Manual.

### 2-5 [DAW REMOTE] button

This calls up the DAW REMOTE screen.

### 2-6 [QUICK SETUP] button (FX BYPASS)

This calls up the *Utility Quick Setup* screen.

Pressing the [QUICK SETUP] button while holding down the [SHIFT] button calls up the screen for making effect bypass settings (*Effect Switch* screen).

## 2-7 [STORE] button (FILE)

This calls up the *Store* screen. On the *Store* screen, you can select to save the Performance under a new name or to overwrite the existing performance.

Pressing [STORE] button while holding down the [SHIFT] button calls up the screen for File settings (FILE screen).

## 2-8 [SPLIT] button (NOTE RANGE)

This calls up the *Split Job* screen for the Performance.

Pressing [SPLIT] button while holding down the [SHIFT] button calls up the screen for setting note ranges (NOTE RANGE screen).

## 2-9 [SONG/PATTERN] button (RHYTHM PATTERN)

This calls up the *Play/Rec* screen for the Performance.

Pressing [SONG/PATTERN] button while holding down the [SHIFT] button calls up the screen for setting Rhythm Patterns (RHYTHM PATTERN screen).

## 2-10 [TEMPO/TAP] button (PANEL LOCK)

This calls up the *Utility Tempo Settings* screen.

Pressing the [TEMPO/TAP] button while holding down the [SHIFT] button locks the panel controls and disables the top panel buttons and touch panel operation. Repeat the operation to unlock the panel controls.

## Controlling the built-in sequencer

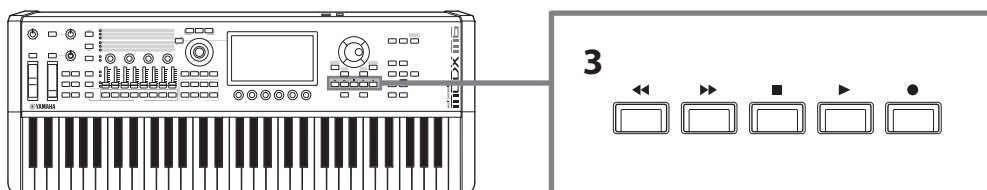

## 3 Sequencer transport buttons

Use these buttons for controlling playback and recording of the sequencer data for Pattern, Song and Audio.

### [◀◀] (Back) button

Use [◀◀] button for moving back one measure at a time.

### [▶▶] (Forward) button

Use [▶▶] button for moving forward one measure at a time.

### [■] (Stop) button

Use [■] button for stopping playback or recording. If you press this button again while playback is currently stopped, the starting point for playback returns to the beginning of the sequencer data.

You can also use this button to stop Arpeggio playback that continues playing after keys are released (in cases where the Arpeggio Hold switch is on).

### [●] (Record) button

This calls up the Recording screen. While the Recording screen is shown, press this button to call up the Recording setup screen (the button starts flashing). When you press the [▶] button, recording starts, and the button stops flashing and lights continuously.

### [▶] (Play) button

Use [▶] button for starting song playback or recording. When playback or recording starts, the button flashes at the tempo of the song. The button lights up continuously for audio.

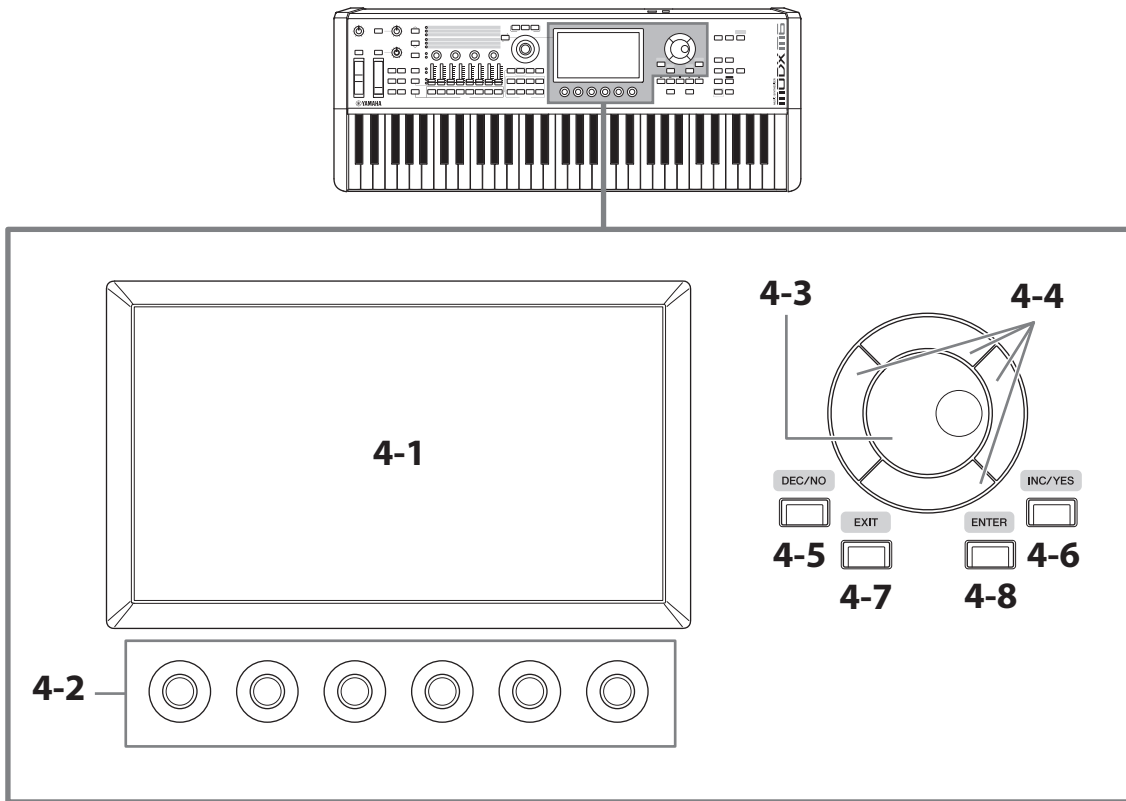

#### 4-1 LCD (touchscreen)

This display shows various information. You can change the settings by touching the screen directly. You can also use the cursor buttons, data dial, and display knobs to move the cursor and change the value. For details, see "Status check and basic operation" (page 34).

#### 4-2 Display knobs

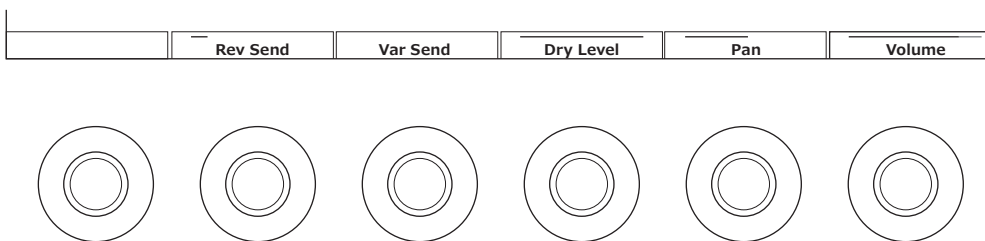

Use these knobs to control the selected row of parameters shown in the display. The knobs directly beneath the parameter names shown at the bottom of the display can be used for changing the corresponding parameter settings.

### **4-3 Data dial**

Use this dial to change the value shown at the cursor position.  
Moving the dial faster lets you change the parameter value in larger increments.

### **4-4 Cursor buttons**

For moving the cursor position up, down, left, and right.

### **4-5 [DEC/NO] button**

Use [DEC/NO] button to decrease the value in increments.  
You can also use this button to select "NO" for the message shown on the *Store* or *Job* screen.  
Pressing [DEC/NO] button while holding down the [SHIFT] button lets you jump through the values in units of 10.

### **4-6 [INC/YES] button**

Use [INC/YES] button to increase the value in increments.  
You can also use this button to select "YES" for the message shown on the *Store* or *Job* screen.  
Pressing [INC/YES] button while holding down the [SHIFT] button lets you jump through the values in units of 10.

### **4-7 [EXIT] button**

The functions shown on the touchscreen are arranged in hierarchical order. Use [EXIT] button to return upward on the hierarchical level.  
If a *Performance* screen other than the *Home* screen is shown, you can use the this button to instantly return to the *Home* screen.

### **4-8 [ENTER] button**

Use [ENTER] button to call up the item shown/selected on the screen. You can also use this button to select "YES" for prompts or messages shown on the *Store* or *Job* screen.

## Controlling parameters in real time as you play the keyboard, and adjusting detailed parameter values

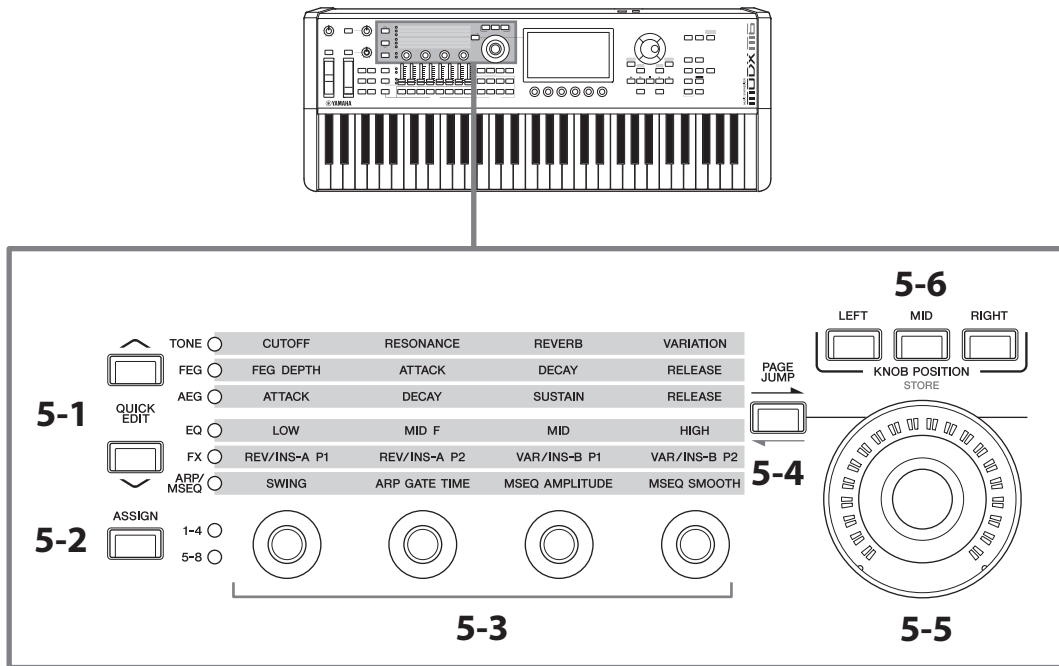

### 5-1 [QUICK EDIT] button

Use knobs 1–4 (5–8) to switch the parameter to be controlled.

Use knobs 1–4 (5–8) to control the parameters of the row whose indicator lamp is lit.

#### Parameters that can be switched with the [QUICK EDIT] buttons

Indicator	Description
TONE	Parameters for tone settings
FEG	Parameters related to filter envelope generator settings
AEG	Parameters related to the amplitude envelope generator settings
EQ	Parameters related to equalizer settings
FX	Parameters for effect settings
ARP/MSEQ	Parameters for Arpeggio and Motion Sequencer playback

To control the parameters of an entire performance, select the name of the Performance on the *Performance* screen (*Home* screen) or press the [COMMON] button.

Use the [QUICK EDIT] buttons to switch to the parameter you want to control, and then operate knobs 1–4 (5–8).

To control the parameters of a specific part, tap the part on the *Performance* screen (*Home* screen) or press the [PART SELECT] button, and then press the PART button.

Use the [QUICK EDIT] buttons to switch to the parameter you want to control, and then operate knobs 1–4 (5–8).

### 5-2 [ASSIGN] button

Switches the knobs to function as Assign 1–4 or as Assign 5–8.

### 5-3 Knobs 1–4 (5–8)

By turning these four knobs, you can control various parameters related to the Part sound, Arpeggio playback, Motion Sequencer, and others.

When the [ASSIGN] button is turned on, knobs 1–4 (5–8) function as assignable knobs (knobs to which functions can be freely assigned).

### 5-4 [PAGE JUMP] button

This calls up the parameter currently being selected with the [QUICK EDIT] buttons.

Pressing the [PAGE JUMP] button while holding down the [SHIFT] button, the parameter that can be switched with the [QUICK EDIT] button will change to match the parameter currently displayed on the screen, and can be controlled with knobs 1–4 (5–8).

### 5-5 Super Knob

You can use this knob to simultaneously control multiple parameters (*Assign* 1–8) assigned to knobs 1–4 (5–8).

You can also control the Super Knob from a connected FC7 foot controller.

For more information on the values controlled with the Super Knob, as well as instructions on how to assign functions to *Assign* 1–8 parameters and how to make settings for the foot controller connections, refer to the Operation Manual.

### 5-6 KNOB POSITION buttons

Pressing the KNOB POSITION buttons switches to the stored Super Knob setting.

After adjusting parameters using knobs 1–4 (5–8), hold down the [SHIFT] button and press one of the KNOB POSITION buttons to save the setting values to the selected button.

The setting values saved for each button can be checked under [PERFORMANCE (HOME)] → *Motion Control* → *Super Knob*.

[LEFT] button	The value corresponding to the leftmost position for the Super knob
[MID] button	The value (the center value) corresponds to the mid position for the Super knob The center value can be assigned to any position on the knob <b>NOTE</b> The [MID] button is available only when the <i>Super Knob Mid Position</i> setting is set to something other than <i>Off</i> .
[RIGHT] button	The value corresponding to the rightmost position for the Super knob

Morphing is possible by storing different setting values for each button. Refer to the Operation Manual for details.

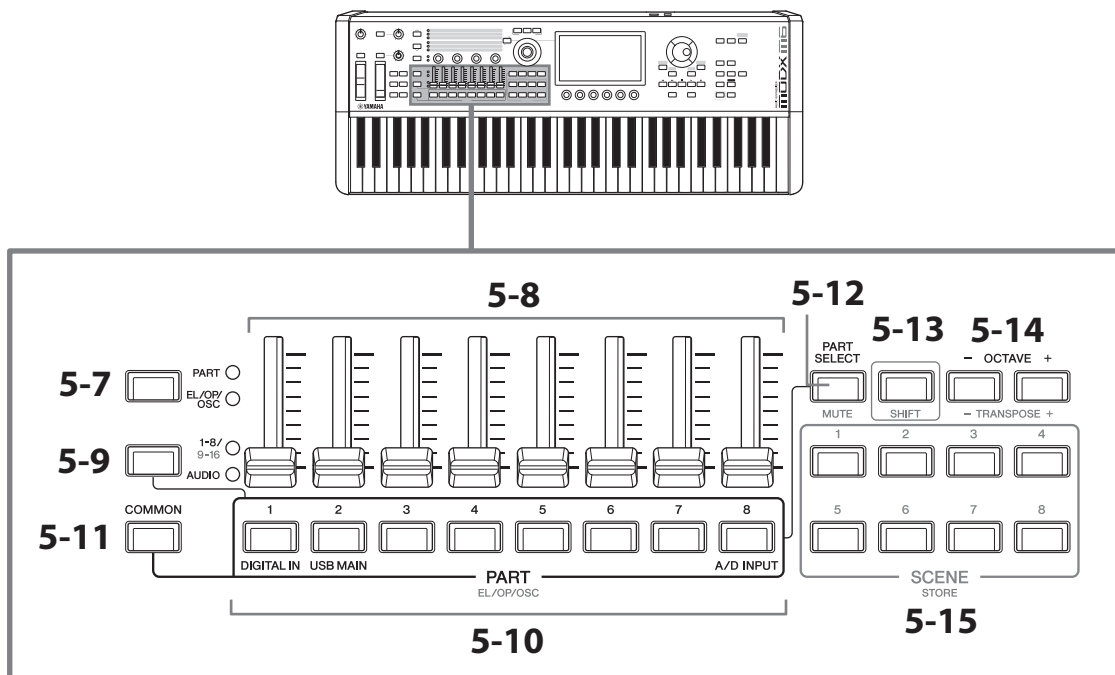

## 5-7 Slider function [PART]/[EL/OP/OSC] button

Use this button to set the eight control sliders for controlling the volume of the Parts or the level of the elements, operators, oscillators, or drum keys. Each time you press the button, the slider function alternates between PART and EL/OP/OSC.

## 5-8 Control sliders 1–8

Use these sliders for real-time control of the volume for Parts 1–16 (1–8/9–16), elements of Normal Parts (AWM2), operators of Normal Parts (FM-X), oscillators of Normal Parts (AN-X), and keys for the Drum Parts.

When the slider function [PART]/[EL/OP/OSC] button is set to “EL/OP/OSC,” the PART buttons select the part, and you can adjust the levels for the element, operator, oscillator, or drum key of the selected part.

### NOTE

- If all Control Sliders are set to the minimum, you may not hear any sound from the instrument, even when playing the keyboard or a Song. If this is the case, move all the sliders to a suitable level.
- The [MASTER VOLUME] knob controls the overall audio output level of this instrument. On the other hand, the Control Sliders control the level of each element/key/operator of the Parts and the volume for each Part of the Performance as a parameter. Accordingly, the values set via the Control Sliders can be stored as Performance data.

## 5-9 Part group [1-8/9-16]/[AUDIO] button

Use this button to set the PART buttons for selecting Parts 1 to 16 or for selecting AUDIO. Each time you press the button, the sliders’ function alternates between 1–8/9–16 and AUDIO.

By pressing Part group [1-8/9-16]/[AUDIO] button while holding down the [SHIFT] button, you can use the PART buttons to control Parts 9–16. When the 1-8/9-16 lamp is on, the PART buttons are set to Parts 1–8, and when the 1-8/9-16 lamp is flashing, the PART buttons are set to Parts 9–16.

## 5-10 PART buttons (EL/OP/OSC)

When the Part group [1-8/9-16]/[AUDIO] button is set to "1-8/9-16," you can use these buttons to select Parts 1–8 or Parts 9–16.

When the Part group [1-8/9-16]/[AUDIO] button is set to "AUDIO," you can use these buttons to select DIGITAL IN, USB MAIN, and A/D INPUT.

By pressing one of these buttons while holding down the [SHIFT] button, you can use the appropriate PART button to select *Elements* 1–8, *Operators* 1–8, *Oscillators* 1–3, or *Noise*.

## 5-11 [COMMON] button

Use this button to select Common operations for the Parts, elements, operators, and oscillators.

## 5-12 [PART SELECT] button (MUTE)

The [PART SELECT] button lights up when the PART button is ready for selection.

By pressing the [PART SELECT] button while holding down the [SHIFT] button, you can set the Part to MUTE on or off. Also, by pressing the [PART SELECT] button while holding down the [SHIFT] button and then pressing one of the PART buttons while holding down the [SHIFT] button, you can use the appropriate PART button to set MUTE to on or off for the particular Element, Operator, or Oscillator.

When the Part is set to MUTE on, you can see the status with the Mute button or the "M" icon on the screen.

## 5-13 [SHIFT] button

Hold down [SHIFT] button along with another button enables you to call up the alternate function printed in red at the bottom of each button.

For the list of functions, refer to the Operation Manual.

## 5-14 OCTAVE buttons (TRANPOSE)

Each time you press the OCTAVE button, the keyboard range moves in octaves.

The OCTAVE button lights or flashes when the octave setting is being changed.

Pressing both buttons at the same time resets the setting to the standard pitch or "0."

To transpose the keyboard, press the desired OCTAVE button while holding down the [SHIFT] button. Each time you press one of the buttons, the pitch of the keyboard moves up or down in semitones.

When the transpose setting is changed from 0, pressing the [SHIFT] button lights the appropriate OCTAVE button.

Holding down the [SHIFT] button and pressing both buttons at the same time resets the setting to the standard pitch or "0."

## 5-15 SCENE buttons (STORE)

You can assign different "snapshots" of important Part-related parameters such as track mute status and basic Mixing setups to each of the SCENE buttons.

The currently selected button fully lights, the button with stored Scene setting lights dimly, and the button with no stored Scene setting is turned off.

By pressing one of these buttons while holding down the [SHIFT] button, you can save the Scene settings you've edited.

### NOTICE

**Make sure to save (store) the Scene settings you have just edited before changing to a different Scene or turning off the instrument. If the Store operation has not been performed, the Scene settings will be lost.**

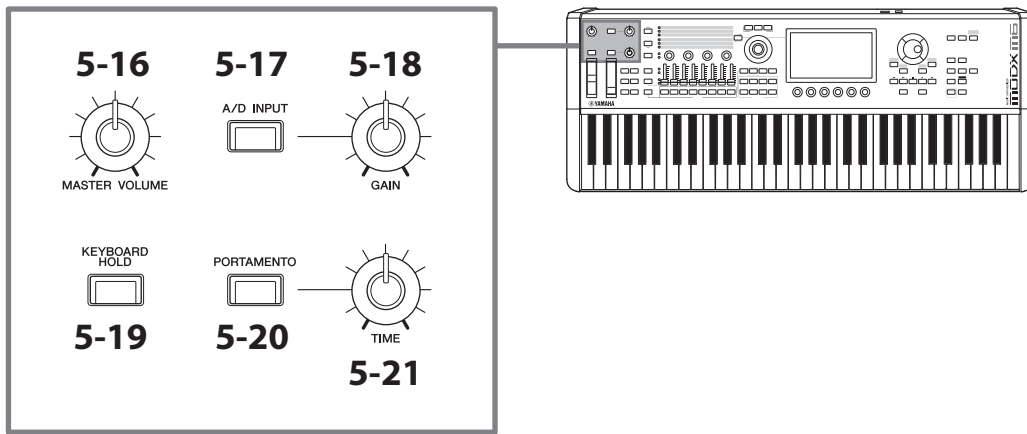

## 5-16 [MASTER VOLUME] knob

Use [MASTER VOLUME] knob for adjusting the Master volume.

## 5-17 [A/D INPUT] button

Use the [A/D INPUT] button to enable or disable the inputs from the A/D INPUT jacks.

Pressing the [A/D INPUT] button while holding the [SHIFT] button calls up the *Mixing* screen of the audio signal input from the A/D INPUT jack.

## 5-18 A/D INPUT [GAIN] knob

Use A/D INPUT [GAIN] knob to adjust the gain for the audio signals input from the A/D INPUT.

### NOTE

You may need to change the gain setting depending on the level of the external equipment connected to the A/D INPUT jacks, in the following order: [UTILITY] → *Settings* → *Audio I/O* → *A/D Input*. When the output level of the connected equipment (such as a microphone) is low, set this parameter to *Mic*. When the output level of the connected equipment (such as a synthesizer keyboard or CD player) is high, set this parameter to *Line*.

For other input-related parameters, change the settings as shown below.

### The Volume for the A/D Input block and send level for the Pan and effects

- [PERFORMANCE (HOME)] → *Mixing*
- [EDIT/↶] → *Audio In* → *Mixing*
- [NAVIGATION] → [COMMON] → *A/D Input*
- or
- [COMMON] → [NAVIGATION] → *A/D Input*
- Set the Part group [1-8/9-16]/[AUDIO] button to "AUDIO," and then press PART button 8.

### Destination for sending audio signals from the A/D INPUT jacks to the specific effect in the Effect block

- [EDIT/↶] → *Audio In* → *Routing*

## 5-19 [KEYBOARD HOLD] button

When this button is turned ON, you can sustain the notes you play without using the sustain pedal. The use of sustain is automatically adjusted to prevent the end of the previous sustained note from blending with the notes of the next chord.

## 5-20 [PORTAMENTO] button

Use [PORTAMENTO] button for setting the Portamento effect on and off. Portamento is a function that creates a smooth transition in pitch from the first note played on the keyboard to the next.

Pressing the [PORTAMENTO] button while holding the [SHIFT] button calls up the portamento setting screen.

## 5-21 PORTAMENTO [TIME] knob

Use PORTAMENTO [TIME] knob for adjusting the Portamento time.

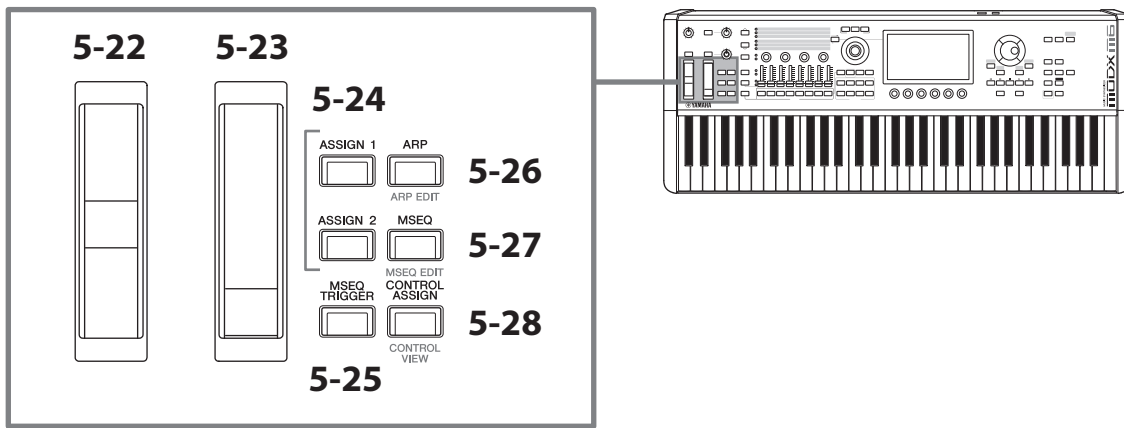

## 5-22 Pitch bend wheel

Use this wheel for controlling the pitch-bend effect.

The pitch bend range can be set from Part Edit → *General/Pitch* → *Pitch*.

You can assign other functions for each Part via Part Edit → *Mod/Control* → *Control Assign*.

## 5-23 Modulation wheel

Controls the modulation effect. You can assign functions individually to each Part via Part Edit → *Mod/Control* → *Control Assign*.

## 5-24 [ASSIGN 1] and [ASSIGN 2] buttons

Use these buttons to control the elements and operators during your performance to create variations in sounds. Other functions can be assigned as well.

To assign other functions individually to each Part, use Part Edit → *Mod/Control* → *Control Assign*.

To control elements that generate sounds by using the XA function (for creating realistic sounds like those on acoustic instruments as well as creating new synth sounds), use Element Edit → *Osc/Tune* → *XA Control*.

Pressing the [ASSIGN 1] or [ASSIGN 2] button while holding down the [SHIFT] button calls up the *Control Setting* screen, from which you can change the Assign 1 or 2 operation mode.

## 5-25 [MSEQ TRIGGER] button

When the [MSEQ] button and the *Motion SEQ Trigger* setting is ON, pressing [MSEQ TRIGGER] button plays back the motion sequence.

## 5-26 [ARP] button (ARP EDIT)

Use this button for enabling or disabling arpeggio playback.

The Arpeggio function lets you trigger rhythm patterns, riffs, and phrases using the current Part by simply playing notes on the keyboard.

It not only provides inspiration and full rhythmic passages in your live performances, but it gives you fully formed instrumental backing parts of various music genres for ease in creating songs.

If the Arpeggio switch for the Part is disabled, setting this button to ON will not playback the arpeggio for that Part.

Pressing the [ARP] button while holding down the [SHIFT] button opens the screen for making Arpeggio settings (ARP EDIT screen).

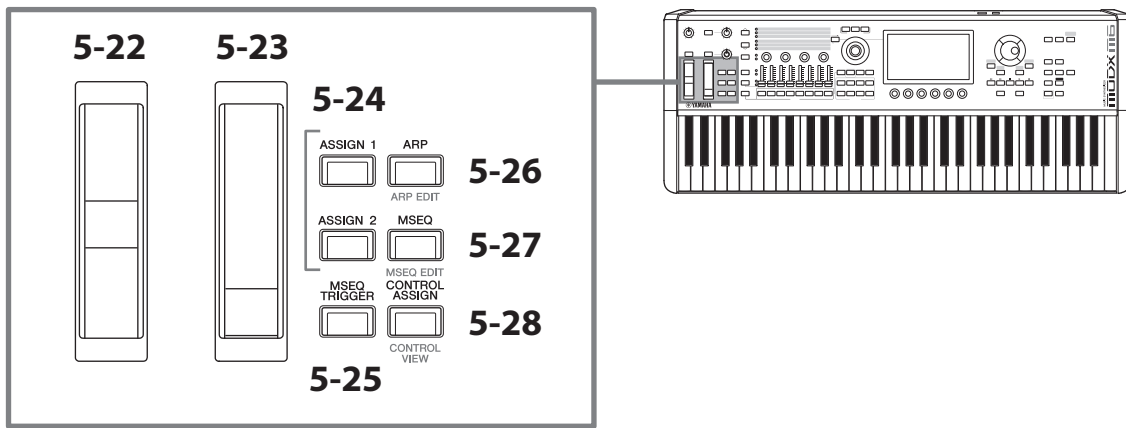

## 5-27 [MSEQ] button (MSEQ EDIT)

Use [MSEQ] button to enable or disable the Motion Sequencer.

If the Motion Sequencer switch for the Part or the Lane is disabled, even setting this button to ON will not enable playback of the Motion Sequence for that Part.

Pressing [MSEQ] button while holding down the [SHIFT] button opens the screen for making Motion Sequencer settings (MSEQ EDIT screen).

## 5-28 [CONTROL ASSIGN] button (CONTROL VIEW)

When parameters that can be assigned to a controller are selected on the screen, pressing this button displays the CONTROL ASSIGN screen. If a controller is operated at this time, the selected parameter will be assigned to that controller.

Pressing the [CONTROL ASSIGN] button while holding down the [SHIFT] button calls up the CONTROL VIEW screen. If a controller is operated at this time, the *Control Assign* screen will open, and the settings assigned to that controller can be confirmed.

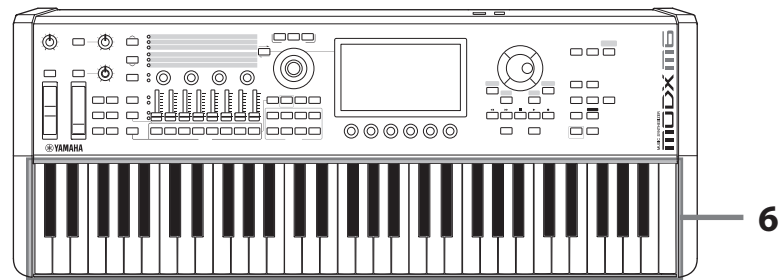

### 6 Keyboard

The MODX M6 features a 61-key keyboard, while the MODX M7 has 76 keys and the MODX M8 has 88 keys. All are equipped with a touch response feature (initial touch). With initial touch, the instrument senses how strongly or softly you play the keys and uses that playing strength to alter the sound in various ways.

## Connecting

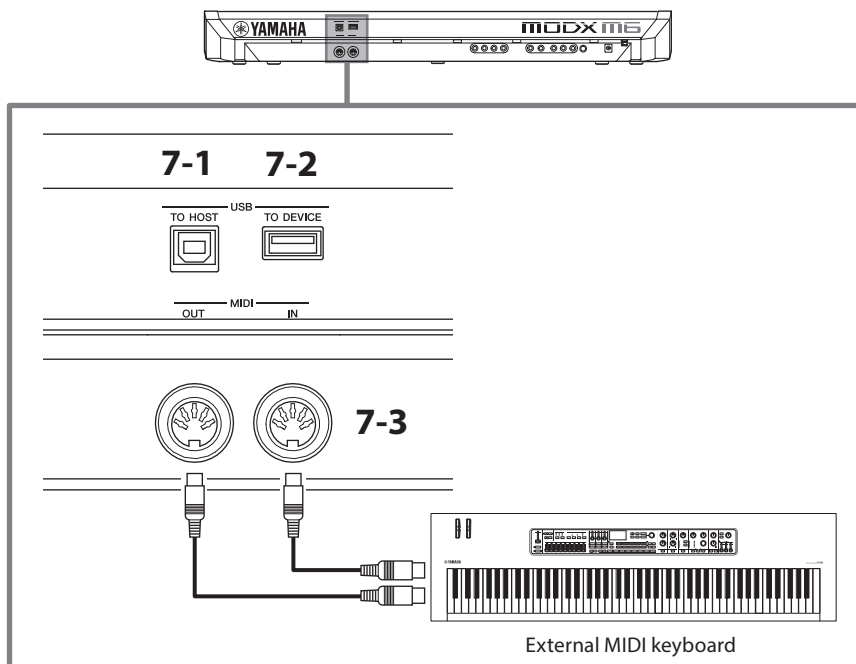

### 7-1 USB [TO HOST] terminal

Using this USB [TO HOST] terminal to connect a computer via a USB cable, allows you to transfer MIDI data and audio data between the devices. Unlike MIDI, USB can handle multiple ports via a single cable. For information about how this instrument handles Ports, refer to the Operation Manual.

#### NOTE

Audio data sending capability for the instrument is a maximum of 10 channels (5 stereo channels) at a sampling frequency of 44.1 kHz.

Audio data receiving capability is a maximum of 4 channels (2 stereo channels).

### 7-2 USB [TO DEVICE] terminal

Use USB [TO DEVICE] terminal for connecting USB flash drives and USB MIDI keyboards.

When a USB flash drive is connected, you can save data created on this instrument to the USB flash drive and load data from the USB flash drive to the instrument. Sending and receiving data between the USB flash drive and this instrument can be set from [UTILITY] → *Contents* → *Save (or Load)*.

When a USB MIDI keyboard is connected, you can use it in the same way as the built-in keyboard of this instrument, as far as the connected keyboard's specifications allow. For more information, refer to the Operation Manual.

### 7-3 MIDI terminals

Use MIDI terminal for connecting external MIDI devices with a MIDI cable. You can play an external MIDI device from the built-in keyboard, or play the tone generator block from an external MIDI device.

The MIDI [OUT] terminal can also be used as a MIDI Thru terminal.

It can be set from [UTILITY] → *Settings* → *MIDI I/O* → *MIDI Thru*.

However, *MIDI Thru* is displayed only when *MIDI IN/OUT* is set to *MIDI*.

## Precautions when using the USB [TO HOST] terminal

When connecting the computer to the USB [TO HOST] terminal, make sure to observe the following important precautions to avoid freezing the computer/instrument and corrupting or losing the data.

### NOTICE

- Use an AB type USB cable. USB 3.0 cables cannot be used.
- Execute the following before turning the power to the instrument on/off or plugging/unplugging the USB cable to/from the USB [TO HOST] terminal.
  - Quit any open application software on the computer.
  - Make sure that data is not being transmitted from the instrument. (Data is transmitted when notes on the keyboard are played or a Song is played back.)
- While the computer is connected to the instrument, you should wait for a few seconds between these operations: (1) when turning the power of the instrument off and then on again, or (2) when alternately connecting/disconnecting the USB cable.

If the computer or the instrument freezes, restart the application software or the computer OS or turn the power to the instrument off and then on again.

## Precautions when using the USB [TO DEVICE] terminal

When connecting a USB device to the USB [TO DEVICE] terminal, check the shape of the terminal and insert it carefully in the proper direction. Also, observe the following precautions.

### ■ Compatible USB devices

- USB flash drive
- USB class compliant MIDI devices (USB MIDI keyboards, etc.)
- Yamaha MIDI devices that have been tested for compatibility

Other USB devices such as a USB hub, computer keyboard, or mouse cannot be used. The instrument does not necessarily support all commercially available USB devices. Yamaha cannot guarantee the operation of USB devices that you purchase.

Before purchasing a USB device for use with this instrument, please visit the following web page:

<https://download.yamaha.com/>

Although USB devices 2.0 to 3.0 can be used on this instrument, the amount of time for saving to or loading from the USB device may differ depending on the type of data or the status of the instrument.

For details on available MIDI devices and their settings and operation when connected, refer to the Operation Manual.

### NOTICE

- The rating of the USB [TO DEVICE] terminal is a maximum of 5 V/500 mA. Do not connect USB devices having a rating above this, since this can cause damage to the instrument itself.
- Use an AB type USB cable of less than 3 meters.
- Avoid connecting or disconnecting the USB device during playback/recording and file management operations (such as Save, Copy, Delete, and Format), or when accessing the USB device. Failure to observe this may result in "freezing" of the operation of the instrument or corruption of the USB device and the data.
- When connecting and then disconnecting the USB device (and vice versa), make sure to wait for a few seconds between the two operations.

### NOTE

For more information about the handling of USB devices, refer to the owner's manual for the USB device.

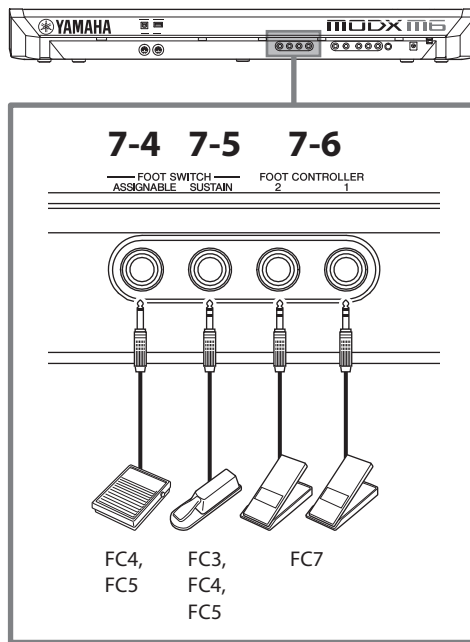

## 7-4 FOOT SWITCH [ASSIGNABLE] jack

## 7-5 FOOT SWITCH [SUSTAIN] jack

Use these jacks for connecting footswitches and a sustain pedal.

The FOOT SWITCH [ASSIGNABLE] is a jack for connecting a separately sold FC4 and FC5 used for functions other than sustain which you have assigned to the pedal. For example, you can use a footswitch to switch to the next Performance while the *Live Set* screen is shown.

FOOT SWITCH [SUSTAIN] is a jack for connecting separately sold foot switches FC3, FC4, and FC5 to use exclusively for sustain.

### NOTE

In this manual, the term "FC3" refers to the FC3 and all other equivalent products, such as the FC3A, and the term "FC4" refers to the FC4 and all other equivalent products, such as the FC4A.

## 7-6 FOOT CONTROLLER jacks

Use these jacks for connecting a separately sold FC7 Foot Controller.

You can assign a function in the Part Edit to control various parameters for the sound, such as its volume and pitch.

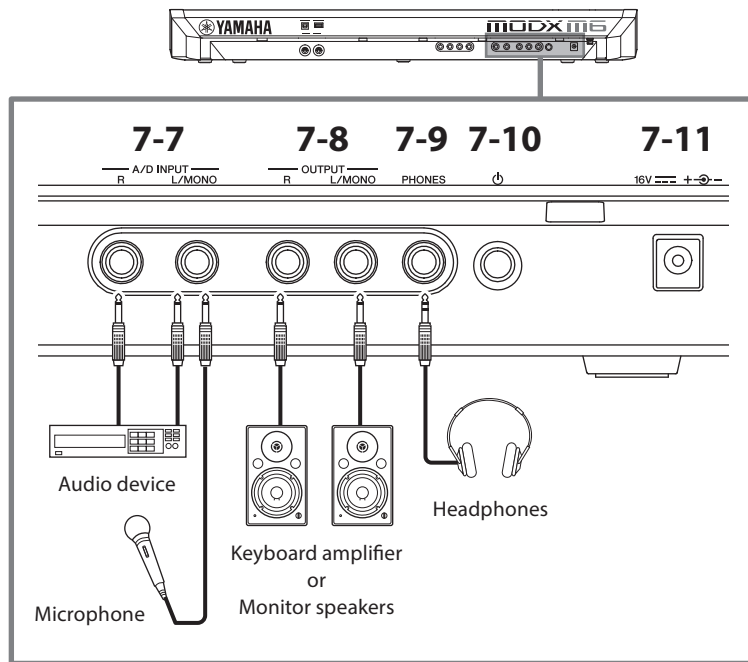

## 7-7 A/D INPUT jacks

Use these standard phone jacks for receiving the audio signals from the external device. Use a standard mono plug for connections.

Stereo devices should be connected to both the [L/MONO] and [R] jacks, while mono devices should only be connected to the [L/MONO] jack. The input audio will be played back as an audio input part. When using the Vocoder function, connect a microphone to the [L/MONO] jack.

In addition, you can also use this jack for the Envelope Follower and ABS (Audio Beat Sync) features. For details refer to the Operation Manual.

### NOTE

A guitar or bass having active pickups can be directly connected. However, when using passive pickups, connect the instrument via an effect device.

## 7-8 OUTPUT jacks

Use these standard phone jacks for outputting the audio signals from this instrument. For mono outputs, use only the [L/MONO] jack.

## 7-9 [PHONES] (headphone) jack

Use this standard stereo phone jack for connecting a set of stereo headphones. This jack outputs audio signals identical to those from the OUTPUT jacks.

## 7-10 [⏻] (Standby/On) switch

Press this to set the power to On (⏻) or Standby (⏻).

## 7-11 DC IN jack

This is for connecting the AC adaptor supplied with this instrument.

# Status check and basic operation

You can check the status by looking at the buttons, sliders, and displays on the top panel. By using the data dial and buttons or by tapping the touchscreen, you can switch to a different screen or change settings.



## Checking the status

### Shown on the top panel

The brightness and the color of the buttons on the top panel indicate the status of the settings.

### Brightness

There are three levels of brightness for the buttons.

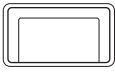
Brightness		Description
	Fully lit	Target setting or function is active or selected.
	Dimly lit	Target setting or function is available but set to OFF. You can press the button to set the function ON.
	Off	Target setting or function is not available and is set to OFF. Nothing occurs when you press the button.

### Color

The color of the slider slits and buttons indicate what they are set to control.

#### Slider slits

Color		Controls
Bright blue	<i>Cyan</i>	<i>Internal Part</i>
Yellow	<i>Yellow</i>	Elements, drum keys, operators, oscillators
Red	<i>Red</i>	Audio
Blue	<i>Blue</i>	Parts in <i>External mode</i> or <i>DAW Remote mode</i>

#### Buttons

Color		Controls
Bright blue	<i>Cyan</i>	<i>Live Set</i> , Part select
Mint green	<i>Mint green</i>	Category
Yellow	<i>Yellow</i>	Element, Operator, Oscillator select
White	<i>White</i>	Real-time control
Magenta	<i>Magenta</i>	Mute
Red	<i>Red</i>	Others

## Display

Below are explanations of the Navigation bar shown on the display at all times.

### Navigation bar

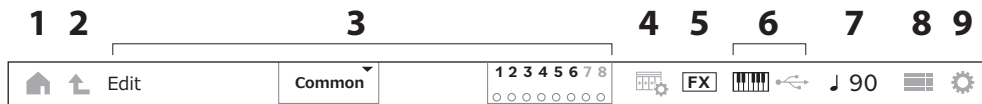

#### 1 HOME icon

The same function as the [PERFORMANCE (HOME)] button on the top panel. Tapping the icon calls up the *Performance* screen (*Home* screen).

#### 2 EXIT icon

The same function as the [EXIT] button on the top panel. Tapping the icon returns one level up in the hierarchical order.





#### 3 INFORMATION area

This area displays information such as the name of the currently selected screen name, the Parts, elements, operators, oscillators, and drum keys.

By tapping ▼, you can change the Part, element, operator, oscillator, and drum key.

##### ● For Normal Parts

When a normal part is selected, the status of the element, operator, and oscillator is displayed on the right side of this area. If the element, operator, and oscillator are muted, an M icon appears below their number.

	<p>Element numbers The element being played is indicated by lights below the numbers. This is useful, for example, when specifying the velocity range for the element to play and confirming that the element is being played.</p>
	<p>This indicates the total number of Elements set. The green bar indicates the volume for the Elements being played.</p>
	<p>Operator numbers</p>
	<p>Oscillator numbers</p>

##### ● For Drum Parts

When a Drum part is selected, the status of the drum keys is displayed on the right side of this area.

	<p>The Drum Keys section shows the total number of drum keys set. The green bar indicates the volume for the Drum Part being played.</p>
---	--

#### 4 VIEW icon

For selecting a view for the *Performance* screen. Tapping the icon calls up the view list of the *Performance* screen.

#### 5 EFFECT icon

Tapping the icon calls up the *Effect Switch* screen. The icon is turned off when an Insertion effect, System effect, or Master effect is turned off.

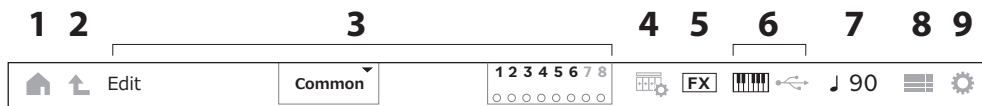

## 6 QUICK SETUP icon

Tapping the icon calls up the MIDI I/O screen.

	Indicates local control on/off When the icon is lit, the setting is on; when the icon is unlit, the setting is off.
	Indicates that MIDI IN and MIDI OUT are set to MIDI
	Indicates that MIDI IN and MIDI OUT are set to USB

## 7 TEMPO SETTINGS icon

The tempo of the currently selected performance is displayed. Tapping the icon calls up the *Tempo Settings* screen.

## 8 LIVE SET icon

Tapping the icon calls up the *Live Set* screen.

## 9 UTILITY icon

Tapping the icon calls up the previously selected tab on the *Utility* screen.

## Navigation button

The “map” of the signal flow of this instrument is shown on the screen. By tapping the item on the map you wish to edit, you can call up the corresponding setting screen.

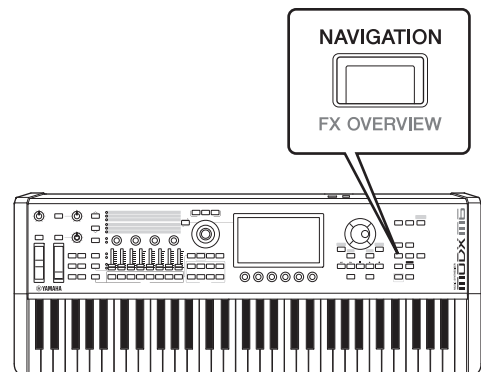

## Performances and Parts

The Performances and the Parts are shown with flags and attributes.

Flags are labels that indicate the sound engine types for the Performance or the Part.

Flag	Descriptions
<b>AWM2</b>	Performance consisting only of AWM2 Parts; Part using AWM2.
<b>FM-X</b> (in 1 color)	Performance consisting only of FM-X Parts; Part using FM-X.
<b>FM-X</b> (in 2 colors)	Performance consisting only of FM-X Parts and <i>Smart Morph</i> ; FM-X Part containing <i>Smart Morph</i> .
<b>AN-X</b> (in 1 color)	Performance consisting only of AN-X Parts; Part using AN-X.
<b>AN-X</b> (in 2 colors)	Performance consisting only of AN-X Parts and <i>Smart Morph</i> ; AN-X Part containing <i>Smart Morph</i> .
<b>MC</b>	Performance that features Motion Control.
<b>SSS</b>	Performance that supports <i>Seamless Sound Switching</i> <i>Seamless Sound Switching</i> (SSS) is a feature that lets you switch Performances smoothly without any notes being cut off. SSS is available when Parts 7 to 16 and the VCM Rotary Speaker effect are not used.

\* The Performances that combine multiple sound engine types are expressed using the "+" sign.

Attributes are labels used to identify types of Performances or Parts. You can use the attribute to filter search results to see only the Performances or Parts that suit your needs.

Attribute	Descriptions
AWM2	AWM2 sound engine
FM-X	FM-X sound engine
AN-X	AN-X sound engine
MC	Performance that features Motion Control
SSS	Performance that supports <i>Seamless Sound Switching</i>
<i>Smart Morph</i>	Performance with <i>Smart Morph</i> settings
<i>Single</i>	Single-Part Performance (Performance containing one Part) Use this when you want to play one instrument sound. The Single-Part Performances are shown in green on the <i>Performance Category Search</i> screen.
<i>Multi</i>	Multi-Part Performance (Performance containing multiple Parts) Use it this when you want to play multiple instruments in layer or split combinations. Multi-Part Performances are shown in blue on the <i>Performance Category Search</i> screen.
MOTIF XF	Factory Performance for MOTIF XF
MONTAGE	Factory Performance for MONTAGE/MODX
MODX M OS Vx.x	Factory Performance for MODX M (x.x is the OS version number)

## Opening setting screens

Touch the LCD to select a screen.

When you select a tab on the first column from the left of the touchscreen, and then select a tab on the second column, the parameter edit view appears.

In the parameter edit view, you can change the parameter value or switch the settings on or off.

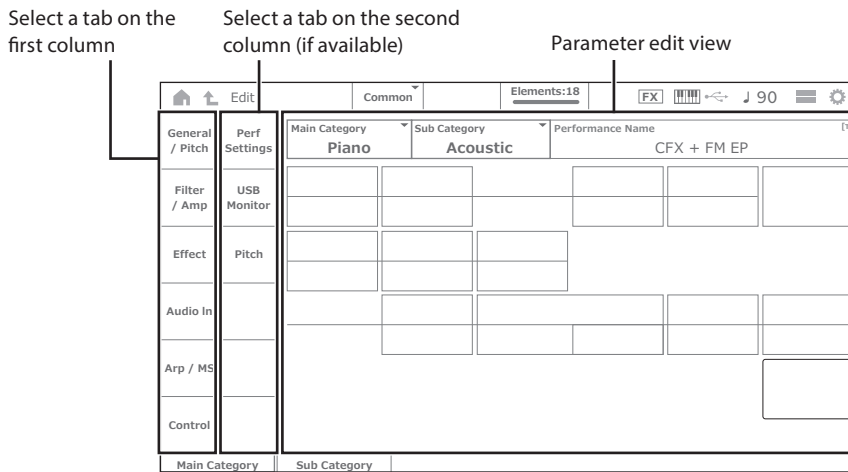

Close the edit view by doing any of the following:

- Press the [EXIT] button.
- Press the [ENTER] button.
- Tap the HOME icon.
- Tap the EXIT icon.

Operation on the touchscreen is performed from left to right.

In the Operation shorthand, it is shown as: the button on the top panel (or the icon in the Navigation bar on the touchscreen) → tab on the first column → tab on the second column → the parameter edit view.

### Example

Operation	[PERFORMANCE (HOME)] → [EDIT/↶] → Part selection → <i>General/Pitch</i> → <i>Part Settings</i>
-----------	--

Operation	[UTILITY] → <i>Settings</i> → <i>Sound</i>
-----------	--

## Moving the cursor and changing parameter values

Use the four cursor buttons on the dial ring to move the cursor on the touchscreen in four directions. You can move the cursor by touching the item shown on the touchscreen.

Change the parameter value at the cursor position by using the data dial, [INC/YES] button, and [DEC/NO] button.

For parameters with large value ranges, you can increase the value by 10 by holding down the [SHIFT] button and pressing the [INC/YES] button. To decrease by 10, hold down the [SHIFT] button and press the [DEC/NO] button.

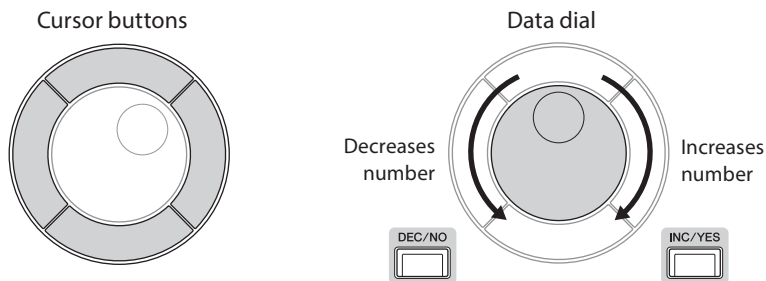



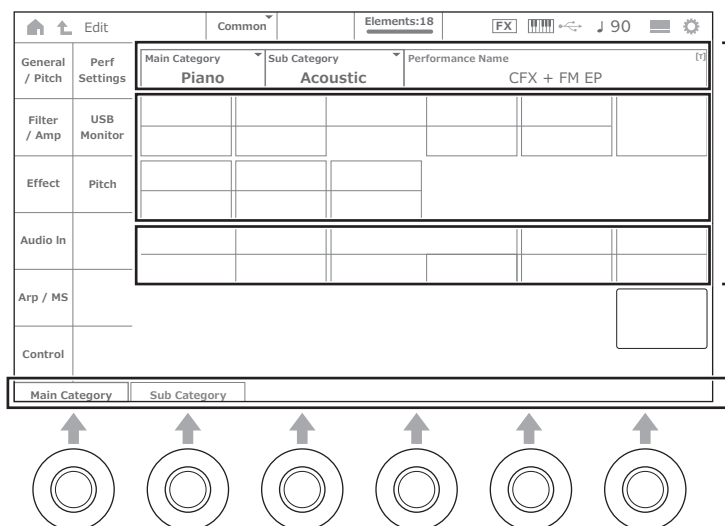



By moving a cursor to a different row of the parameters using the up and down buttons, you can control a different set of parameters using the display knobs.

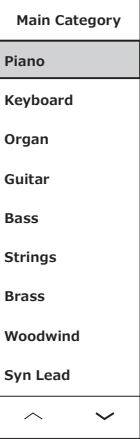

1. Move the cursor up and down to select a different row.

2. Use the display knobs to control the indicated parameters.

## Icons shown for specific operations

Icons	Operations
	<p>The context menu appears Tap to display the context menu.</p>  <p>Tap the context menu button to switch operation screens.</p>
	<p>The pop-up list appears Tap to display a pop-up list. When there are many items, up and down scroll buttons are available.</p>  <p>Touch the item that you wish to select from the list. To close the pop-up list, you can press the [ENTER] or [EXIT] button on the top panel, or tap outside the pop-up list on the screen.</p>
	<p>The screen for entering names appears</p>
	<p>Move to a different screen</p>
	<p>Add a Part</p>

# Entering characters and numbers

## Entering characters

To enter characters, use the keyboard shown on the screen.

The keyboard screen appears when you select the item that requires entering names by tapping the item on the screen or by moving the cursor to the item and pressing the [ENTER] button.

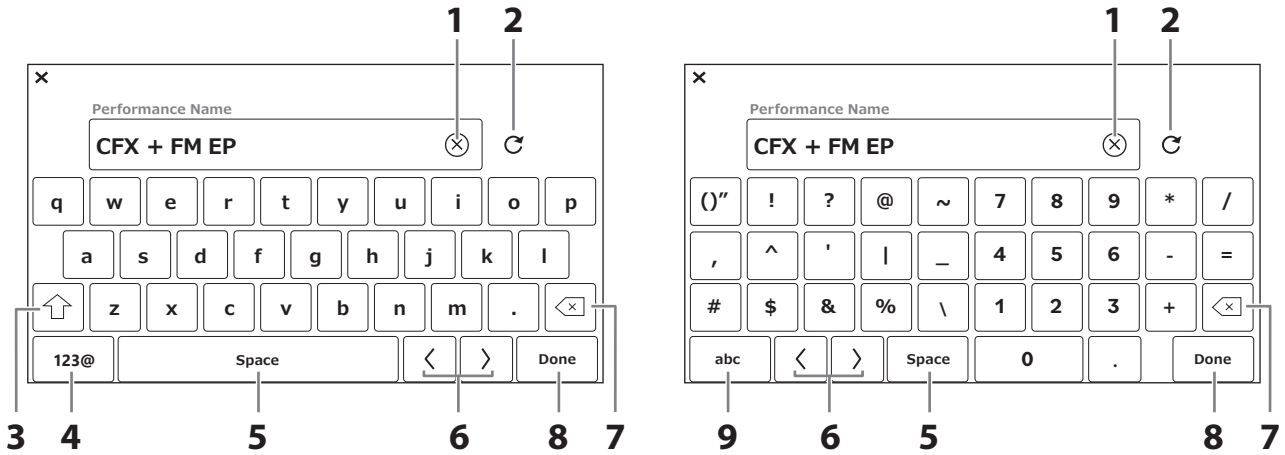

<b>1</b>	Delete all characters
<b>2</b>	Cancel all character changes on the screen
<b>3</b>	Switch between upper case and lower case
<b>4</b>	Switch to the keyboard for entering symbols
<b>5</b>	Insert a space at the cursor position (same as the [INC/YES] button)
<b>6</b>	Move the cursor
<b>7</b>	Delete one character (same as using the [DEC/NO] button)
<b>8</b>	Finish entering characters and close the screen
<b>9</b>	Switch to the keyboard for entering alphabetical characters

## Entering numbers

For entering numbers, you can use the keys on the built-in keyboard or the numeric pad shown on the screen.

When you select a parameter for which note number or velocity is to be entered numerically, you can press the built-in keyboard to enter the numerical value.

When you select a parameter for which velocity is entered numerically, you can use the numeric pad on the screen to enter numerical values.

By tapping the corresponding item on the screen or by moving the cursor and pressing the [ENTER] button, the following tab appears.

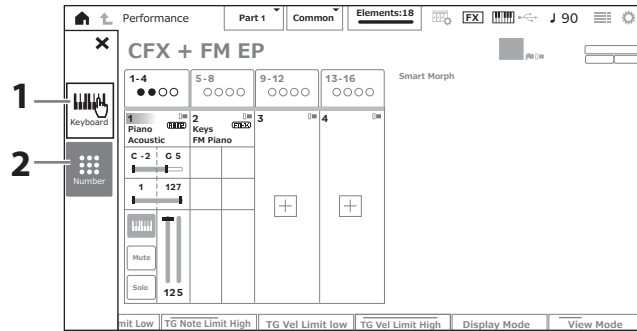

<b>1</b>	Enables keyboard entry Press a key on the built-in keyboard to enter the corresponding value for the note number or velocity.
<b>2</b>	Calls up the numeric pad screen Tap the numbers on the numeric keypad on the screen or use the Data dial, [INC/YES], and [DEC/NO] buttons to increase or decrease the value.

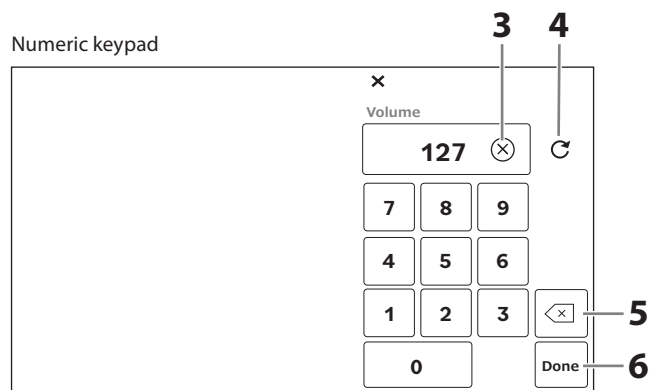

<b>3</b>	Deletes all numbers
<b>4</b>	Cancels the changes on the screen
<b>5</b>	Deletes the last digits
<b>6</b>	Finish entering numbers and close the screen

# Playing the keyboard

First, select a preset Performance from the *Live Set* screen and try playing the keyboard.

## Selecting a Performance from the *Live Set* screen

### 1. Press the [LIVE SET] button.

The *Live Set* screen appears.

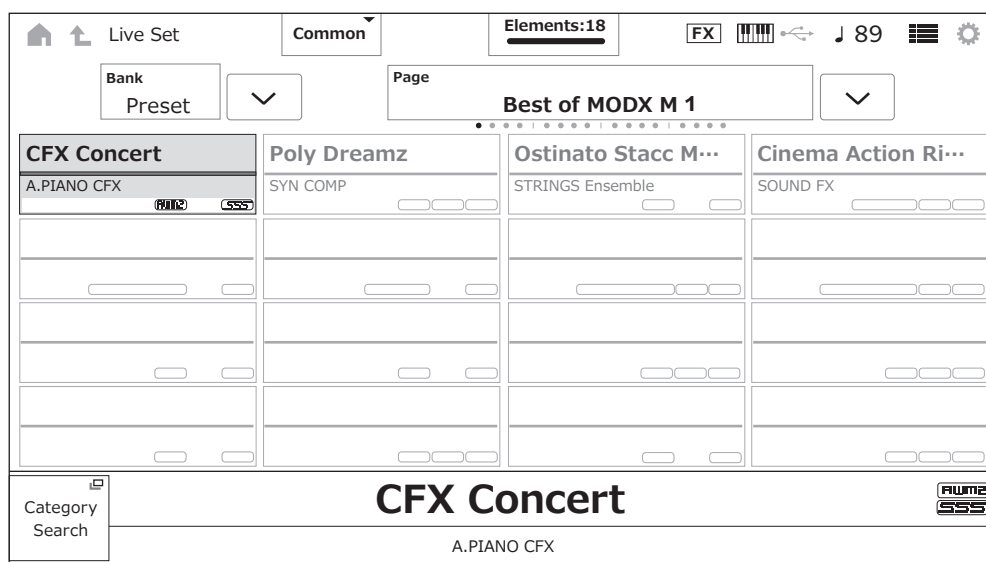

### 2. Find the desired Performance, and touch the Performance name on the screen to select it.

### 3. Play the keyboard.

You can also use the *Performance* screen to select a preset Performance and edit Performance settings. For more information, refer to the Operation Manual.

# Troubleshooting

No sound? Wrong sound? When these or other problems occur, make sure to check the troubleshooting section in the Operation Manual before assuming that the product is faulty. Many problems can be solved by carrying out the *Initialize All Data* operation (below), after backing up your data to a USB flash drive. If the problem persists, consult your Yamaha dealer.

## Restoring the factory default settings (*Initialize All Data*)

---

### NOTICE

When the *Initialize All Data* function is carried out, all the Performances and songs in the User memory you have stored, as well as the Utility settings for the overall keyboard settings will be overwritten with their defaults. Make sure you are not overwriting any important data. Therefore, you should regularly save backups of important settings to a USB flash drive (refer to the Operation Manual).

### 1. Open the Settings screen from [UTILITY] → *Settings* → *System*.

This calls up the setting screen for the entire instrument.

### 2. Tap *Initialize All Data*.

The confirmation screen appears.

To cancel the operation, tap the *Cancel (No)* on the screen or press the [DEC/NO] button on the top panel.

### 3. Tap the *Initialize (YES)* on the screen or press the [INC/YES] button on the top panel.

The *Initialize All Data* operation is carried out.

# Specifications

<b>Keyboard</b>	MODX M8: 88 keys, GHS Keyboard (Initial Touch) MODX M7: 76 keys, Semi-weighted FSB Keyboard (Initial Touch) MODX M6: 61 keys, Semi-weighted FSB Keyboard (Initial Touch)	
<b>Tone Generator</b>	Motion Control Synthesis Engine AWM2: 128 Elements (max.) FM-X: 8 Operators, 88 Algorithms AN-X: 3 Oscillators, 1 noise generator	
<b>Display</b>	7" TFT Color Wide VGA LCD touchscreen	
<b>Connectivity</b>	USB [TO DEVICE], USB [TO HOST], MIDI [IN]/[OUT], FOOT SWITCH [ASSIGNABLE]/[SUSTAIN], FOOT CONTROLLER [1]/[2], A/D INPUT [L/MONO]/[R] (6.3 mm, standard phone jacks), OUTPUT [L/MONO]/[R] (6.3 mm, standard phone jacks), [PHONES] (6.3 mm, standard stereo phone jack)	
<b>Power Supply</b>	<b>AC Adaptor</b>	PA-300C (Output: DC 16 V, 2.4 A)
	<b>Power Consumption</b>	19 W (When using PA-300C AC adaptor)
<b>Standby Power Consumption</b>	0.3 W	
<b>Dimensions, Weight</b>	MODX M8: 1,310 (W) × 391 (D) × 152 (H) mm, 13.6 kg (51-9/16" (W) × 15-3/8" (D) × 5-15/16" (H), 29 lb 15 oz) MODX M7: 1,089 (W) × 347 (D) × 117 (H) mm, 7.6 kg (42-7/8" (W) × 13-11/16" (D) × 4-5/8" (H), 16 lb 12 oz) MODX M6: 882 (W) × 347 (D) × 117 (H) mm, 6.6 kg (34-3/4" (W) × 13-11/16" (D) × 4-5/8" (H), 14 lb 9 oz)	
<b>Included Accessories</b>	AC adaptor*: PA-300C, Quick guide (this book), Cubase AI Download Information, Expanded Softsynth Plugin for MONTAGE M/MODX M Download Information, About downloading manuals, Welcome card * May not be included depending on your area. Check with your Yamaha dealer.	

The complete list of specifications is available on the following website.

<https://www.yamaha.com/2/modxm>

\* The contents of this manual apply to the latest specifications as of the publishing date. Since specifications, equipment or separately sold accessories may not be the same in every locale, please check with your Yamaha dealer.

# Index

## A

AN-X .....	9, 37
attribute .....	37
Auto Power Off function .....	11
AWM2 .....	9, 37

## B

bank .....	15
------------	----

## D

Drum Parts (AWM2) .....	14
-------------------------	----

## E

Envelope Follower .....	9
-------------------------	---

## F

factory default settings .....	44
flag .....	37
FM-X .....	9, 37

## H

Hybrid sound engine .....	9
---------------------------	---

## I

Init .....	14
------------	----

## L

Library bank .....	15
Live Set .....	15

## M

Motion Control .....	9, 14, 37
Motion Control Synthesis Engine .....	9
Motion Sequencer .....	9
Multi/GM .....	14
Multi-Part Performance .....	14, 37

## N

Normal Parts (AN-X) .....	14
Normal Parts (AWM2) .....	14
Normal Parts (FM-X) .....	14

## P

Part .....	14
Performance .....	14
Preset bank .....	15

## S

Single-Part Performance .....	14, 37
slot .....	15
Soundmodo .....	14
SSS .....	37
Super Knob .....	9

## U

User bank .....	15
-----------------	----

## V

Voice .....	14
-------------	----

## Note on source code distribution

For three years after the final factory shipment, you may request from Yamaha the source code for any portions of the product which are licensed under the GNU General Public License or GNU Lesser General Public License by writing to the following address:

Digital Musical Instruments Marketing & Sales Group, Digital Musical Instruments Division  
Musical Instruments & Audio Products Business Unit, Yamaha Corporation  
10-1 Nakazawa-cho, Chuo-ku, Hamamatsu, 430-8650, JAPAN

The source code will be provided at no charge; however, we may require you to reimburse Yamaha for the cost of delivering the source code to you.

- Note that we shall bear no responsibility whatsoever for any damage arising from changes (additions/deletions) made to the software for this product by a third party other than Yamaha (or party authorized by Yamaha).
- Note that re-use of source code released to the public domain by Yamaha is unguaranteed, and Yamaha shall not bear any responsibility whatsoever for the source code.
- The source code can be downloaded from the following address:  
<https://download.yamaha.com/sourcecodes/synth/>

## Important Notice: Power management information for customers in European Economic Area (EEA), Switzerland and Turkey

### Remarque importante : Informations sur la gestion de l'alimentation pour les clients de l'Espace économique européen (EEE), de Suisse et de Turquie

Yamaha products are equipped with a power management function. Some products allow you to disable that function, or to extend the amount of time that elapses before the power is turned off or set to standby. In these cases, energy consumption will increase.	English
Yamaha-Produkte sind mit einer Power-Management-Funktion ausgestattet. Bei einigen Produkten können Sie diese Funktion ausschalten oder die Zeitdauer, die verstreicht, bis das Instrument ausgeschaltet oder in Bereitschaft versetzt wird, verlängern. In diesen Fällen erhöht sich der Energieverbrauch.	Deutsch
Les produits Yamaha sont équipés d'une fonction de gestion de l'alimentation. Certains produits vous permettent de désactiver cette fonction ou d'allonger le délai avant la mise hors tension ou la mise en veille. Dans ces cas, la consommation d'énergie augmente.	Français
Yamaha-producten zijn uitgerust met een energiebeheerfunctie. Bij sommige producten kunt u die functie uitschakelen of de tijd verlengen die verstrijkt voordat de stroom wordt uitgeschakeld of in stand-by wordt gezet. In deze gevallen zal het energieverbruik toenemen.	Nederlands
Los productos Yamaha están equipados con una función de administración de energía. Algunos productos permiten desactivar esa función o ampliar el tiempo que transcurre antes de apagar la alimentación o poner el producto en modo de espera. En estos casos, el consumo de energía aumentará.	Español
I prodotti Yamaha sono dotati di una funzione di gestione dell'alimentazione. Alcuni prodotti consentono di disattivare tale funzione o di estendere il periodo di tempo che trascorre prima che l'alimentazione venga spenta o impostata in standby. In questi casi, il consumo energetico aumenterà.	Italiano
Os produtos Yamaha são equipados com uma função de gerenciamento de energia. Alguns produtos permitem desativar essa função ou estender o tempo decorrido antes de se desligar ou entrar em standby. Nesses casos, o consumo de energia aumentará.	Português
Τα προϊόντα της Yamaha είναι εξοπλισμένα με μια λειτουργία διαχείρισης ισχύος. Ορισμένα προϊόντα σας δίνουν τη δυνατότητα να απενεργοποιείτε αυτή τη λειτουργία ή να επεκτείνετε το χρονικό διάστημα μέχρι την απενεργοποίηση ή τη θέση σε κατάσταση αναμονής. Σε αυτές τις περιπτώσεις, η κατανάλωση ενέργειας θα αυξηθεί.	Ελληνικά
Yamaha-produkterna är utrustade med en energihanteringsfunktion. För vissa produkter kan du inaktivera den funktionen eller för att förlänga tiden som förlutit innan strömmen stängs av eller ställs i vänteläge. I dessa fall ökar energiförbrukningen.	Svenska
Yamahas produkter har en strømstyringsfunktion. På nogle produkter er det muligt at deaktivere denne funktion eller at forlænge den tid, der går, før der slukkes for strømmen, eller sættes på standby. I disse tilfælde vil strømforbruget stige.	Dansk
Yamaha-tuotteet on varustettu virranhallintatoiminnolla. Joissakin tuotteissa voit poistaa toiminnon käytöstä tai pidentää aikaa, joka kuluu ennen virran katkaisemista tai valmiustilaan asettamista. Näissä tapauksissa energiankulutus kasvaa.	Suomi
Produkty Yamaha są wyposażone w funkcję zarządzania energią. Niektóre produkty umożliwiają wyłączenie tej funkcji lub wydłużenie czasu, jaki upływa do wyłączenia zasilania lub przejścia w tryb gotowości. W takich przypadkach zużycie energii wzrośnie.	Polski
Produkty Yamaha jsou vybaveny funkcí správy napájení. Některé produkty umožňují tuto funkci zakázat nebo prodloužit dobu, která má uběhnout před vypnutím napájení nebo pohotovostním režimem. V těchto případech se zvýší spotřeba elektřiny.	Čeština
A Yamaha termékék energiamedzszment funkcióval vannak ellátva. Egyes termékék lehetővé teszik, hogy letiltsa ezt a funkciót, vagy meghosszabbítsa a kikapcsolás vagy készenléti állapotba helyezés előtt eltelt időt. Ezekben az esetekben az energiafogyasztás növekedni fog.	Magyar
Yamaha tooted on varustatud toitehalduse funktsiooniga. Mõned tooted võimaldavad teil selle funktsiooni keelata või pikendada aega, mis möödub enne toite väljalülitamist või ooterežiimi seadmist. Sellistel juhtudel suureneb energiatarbimine.	Eesti
Yamaha izstrādājumi ir aprīkoti ar barošanas pārvaldības funkciju. Dažiem izstrādājumiem šo funkciju var atspējot vai paildzināt laiku, kam jāpaiet pirms barošanas atslēgšanas vai pāriešanas gaidstāves režīmā. Šādā gadījumā palielināsies enerģijas patēriņš.	Latviešu
„Yamaha“ gaminiuose yra energijos sąnaudų valdymo funkcija. Kai kurie gaminiai leidžia išjungti šią funkciją arba pratęsti laiką, praėjusį prieš išjungiant maitinimą arba įjungiant budėjimo režimą. Tokiais atvejais energijos suvartojimas padidės.	Lietuvių
Produkty spoločnosti Yamaha sú vybavené funkciou správy napájania. Niektoré produkty vám umožňujú túto funkciu vypnúť alebo predĺžiť čas, po uplynutí ktorých sa napájanie vypne alebo nastaví do pohotovostného režimu. V takýchto prípadoch sa zvýši spotreba energie.	Slovenčina
Yamahini izdelki imajo funkcijo upravljanja z napajanjem. Nekateri izdelki vam omogočajo, da onemogočite to funkcijo ali podaljšate čas, ki mora preteči, preden se napajanje izklopi ali nastavi v stanje pripravljenosti. V teh primerih se bo poraba energije povečala.	Slovenščina
Продуктите на Yamaha са снабдени с функция за управление на захранването. Някои продукти ви позволяват да забраните тази функция или да удължите времето, което ще изтече, преди захранването да се изключи или да се настрои в режим на готовност. В тези случаи консумацията на енергия ще се увеличи.	Български
Produsele Yamaha sunt echipate cu o funcție de gestionare a energiei. Unele produse vă permit să dezactivați această funcție sau să prelungiți perioada de timp care trece înainte ca alimentarea să fie oprită sau setată în standby. În aceste cazuri, consumul de energie va crește.	Română
Yamaha proizvodi opremljeni su funkcijom upravljanja potrošnjom energije. Neki vam proizvodi omogućuju onemogućavanje te funkcije ili produženje vremena koje protekne prije isključivanja napajanja ili postavljanja u stanje pripravnosti. U tim će se slučajevima povećati potrošnja energije.	Hrvatski
Yamaha ürünlerinde güç yönetimi işlevi vardır. Bazı ürünler, bu işlevi devre dışı bırakmanıza veya güç kapatılmadan ya da bekleme moduna alınmadan önce geçen süreyi uzatmanıza olanak tanır. Bu gibi durumlarda, enerji tüketimi artacaktır.	Türkçe



**Important Notice:**

**U.S. LIMITED WARRANTY for Customers in the United States**

For detailed information about this Yamaha product and warranty service, please either visit the following website address (printable file is available at our website) or contact Customer Service at the address or telephone number identified below.

**Website Address:**

[Yamaha.io/SynthAndStageWarranty](http://Yamaha.io/SynthAndStageWarranty)

**Customer Service:**

Yamaha Corporation of America  
6600 Orangethorpe Avenue, Buena Park, CA 90620  
Telephone: 800-854-1569



# Important Notice: Guarantee Information for customers in European Economic Area (EEA) and Switzerland

<b>Important Notice: Guarantee Information for customers in EEA* and Switzerland</b> For detailed guarantee information about this Yamaha product, and Pan-EEA* and Switzerland warranty service, please either visit the website address below (Printable file is available at our website) or contact the Yamaha representative office for your country. * EEA: European Economic Area	<b>English</b>
<b>Wichtiger Hinweis: Garantie-Information für Kunden in der EWR* und der Schweiz</b> Für nähere Garantie-Information über dieses Produkt von Yamaha, sowie über den Pan-EWR*- und Schweizer Garantieservice, besuchen Sie bitte entweder die folgend angegebene Internetadresse (eine druckfähige Version befindet sich auch auf unserer Webseite), oder wenden Sie sich an den für Ihr Land zuständigen Yamaha-Vertrieb. *EWR: Europäischer Wirtschaftsraum	<b>Deutsch</b>
<b>Remarque importante: informations de garantie pour les clients de l'EEE et la Suisse</b> Pour des informations plus détaillées sur la garantie de ce produit Yamaha et sur le service de garantie applicable dans l'ensemble de l'EEE ainsi qu'en Suisse, consultez notre site Web à l'adresse ci-dessous (le fichier imprimable est disponible sur notre site Web) ou contactez directement Yamaha dans votre pays de résidence. * EEE : Espace Economique Européen	<b>Français</b>
<b>Belangrijke mededeling: Garantie-informatie voor klanten in de EER* en Zwitserland</b> Voor gedetailleerde garantie-informatie over dit Yamaha-product en de garantieservice in heel de EER* en Zwitserland, gaat u naar de onderstaande website (u vindt een afdrukbaar bestand op onze website) of neemt u contact op met de vertegenwoordiging van Yamaha in uw land. * EER: Europese Economische Ruimte	<b>Nederlands</b>
<b>Aviso importante: información sobre la garantía para los clientes del EEE* y Suiza</b> Para una información detallada sobre este producto Yamaha y sobre el soporte de garantía en la zona EEE* y Suiza, visite la dirección web que se incluye más abajo (la versión del archivo para imprimir esta disponible en nuestro sitio web) o póngase en contacto con el representante de Yamaha en su país. * EEE: Espacio Económico Europeo	<b>Español</b>
<b>Avviso importante: informazioni sulla garanzia per i clienti residenti nell'EEA* e in Svizzera</b> Per informazioni dettagliate sulla garanzia relativa a questo prodotto Yamaha e l'assistenza in garanzia nei paesi EEA* e in Svizzera, potete consultare il sito Web all'indirizzo riportato di seguito (è disponibile il file in formato stampabile) oppure contattare l'ufficio di rappresentanza locale della Yamaha. * EEA: Area Economica Europea	<b>Italiano</b>
<b>Aviso importante: informações sobre as garantias para clientes da AEE* e da Suíça</b> Para obter uma informação pormenorizada sobre este produto da Yamaha e sobre o serviço de garantia na AEE* e na Suíça, visite o site a seguir (o arquivo para impressão está disponível no nosso site) ou entre em contato com o escritório de representação da Yamaha no seu país. * AEE: Área Económica Europeia	<b>Português</b>
<b>Σημαντική σημείωση: Πληροφορίες εγγύησης για τους πελάτες στον ΕΟΧ* και Ελλάδα</b> Για λεπτομερείς πληροφορίες εγγύησης σχετικά με το παρόν προϊόν της Yamaha και την κάλυψη εγγύησης σε όλες τις χώρες του ΕΟΧ και την Ελλάδα, επισκεφτείτε την παρακάτω ιστοσελίδα (Εκτυπώσιμη μορφή είναι διαθέσιμη στην ιστοσελίδα μας) ή απευθυνθείτε στην αντιπροσωπεία της Yamaha στη χώρα σας. * ΕΟΧ: Ευρωπαϊκός Οικονομικός Χώρος	<b>Ελληνικά</b>
<b>Viktigt: Garantiinformation för kunder i EES-området* och Schweiz</b> För detaljerad information om denna Yamahaprodukt samt garantiservice i hela EES-området* och Schweiz kan du antingen besöka nedanstående webbadress (en utskriftsvänlig fil finns på webbplatsen) eller kontakta Yamahas officiella representant i ditt land. * EES: Europeiska Ekonomiska Samarbetsområdet	<b>Svenska</b>
<b>Viktig merknad: Garantiinformasjon for kunder i EØS* og Sveits</b> Detaljert garantiinformasjon om dette Yamaha-produktet og garantiservice for hele EØS-området* og Sveits kan fås enten ved å besøke nettstedene nedenfor (utskriftsversjon finnes på våre nettsider) eller kontakte Yamahas kontoret i landet der du bor. *EØS: Det europeiske økonomiske samarbeidsområdet	<b>Norsk</b>
<b>Vigtig oplysning: Garantioplysninger til kunder i EØ* og Schweiz</b> De kan finde detaljerede garantioplysninger om dette Yamaha-produkt og den fælles garantiserviceordning for EØ* (og Schweiz) ved at besøge det websted, der er angivet nedenfor (der findes en fil, som kan udskrives, på vores websted), eller ved at kontakte Yamahas nationale repræsentationskontor i det land, hvor De bor. * EØ: Det Europæiske Økonomiske Område	<b>Dansk</b>
<b>Tärkeä ilmoitus: Takuutiedot Euroopan talousalueen (ETA)* ja Sveitsin asiakkaille</b> Tämän Yamaha-tuotteen sekä ETA-alueen ja Sveitsin takuuta koskevat yksityiskohtaiset tiedot saatte alla olevasta nettiosoitteesta. (Tulostettava tiedosto saatavissa sivustollamme.) Voitte myös ottaa yhteyttä paikalliseen Yamaha-edustajaan. *ETA: Euroopan talousalue	<b>Suomi</b>
<b>Ważne: Warunki gwarancyjne obowiązujące w EOG* i Szwajcarii</b> Aby dowiedzieć się więcej na temat warunków gwarancyjnych tego produktu firmy Yamaha i serwisu gwarancyjnego w całym EOG* i Szwajcarii, należy odwiedzić wskazaną poniżej stronę internetową (Plik gotowy do wydruku znajduje się na naszej stronie internetowej) lub skontaktować się z przedstawicielstwem firmy Yamaha w swoim kraju. * EOG — Europejski Obszar Gospodarczy	<b>Polski</b>
<b>Důležité oznámení: Záruční informace pro zákazníky v EHS* a ve Švýcarsku</b> Podrobné záruční informace o tomto produktu Yamaha a záručním servisu v celém EHS* a ve Švýcarsku naleznete na níže uvedené webové adrese (soubor k tisku je dostupný na našich webových stránkách) nebo se můžete obrátit na zástupce firmy Yamaha ve své zemi. * EHS: Evropský hospodářský prostor	<b>Česky</b>
<b>Fontos figyelemzetés: Garancia-információk az EGT* területén és Svájcban élő vásárlók számára</b> A jelen Yamaha termékre vonatkozó részletes garancia-információk, valamint az EGT*-re és Svájcra kiterjedő garanciális szolgáltatás tekintetében keresse fel webhelyünket az alábbi címen (a webhelyen nyomtatható fájl is található), vagy pedig lépjen kapcsolatba az országában működő Yamaha képviselői irodával. * EGT: Európai Gazdasági Térség	<b>Magyar</b>
<b>Oluline märkus: Garantiiteave Euroopa Majanduspiirkonna (EMP)* ja Šveitsi klientidele</b> Täpsemat teabes saamiseks selle Yamaha toote garantii ning kogu Euroopa Majanduspiirkonna ja Šveitsi garantiiteeninduse kohta, külastage palun veebisaiti alljärgneval aadressil (meie saidil on saadaval printitav fail) või pöörduge Teie regiooni Yamaha esinduse poole. * EMP: Euroopa Majanduspiirkond	<b>Eesti keel</b>
<b>Svarīgs paziņojums: garantijas informācija klientiem EEZ* un Šveicē</b> Lai saņemtu detalizētu garantijas informāciju par šo Yamaha produktu, kā arī garantijas apkalpošanu EEZ* un Šveicē, lūdzmu, apmeklējiet zemāk norādīto tīmekļa vietnes adresi (tīmekļa vietnē ir pieejams drukājams fails) vai sazinieties ar jūsu valsti apkalpojošo Yamaha pārstāvniecību. * EEZ: Eiropas Ekonomikas zona	<b>Latviešu</b>
<b>Dėmesio: informacija dėl garantijos pirkėjams EEE* ir Šveicarijoje</b> Jei reikia išsamios informacijos apie šį „Yamaha“ produktą ir jo techninę priežiūrą visoje EEE* ir Šveicarijoje, apsilankykite mūsų svetainėje toliau nurodytu adresu (svetainėje yra spausdintinas failas) arba kreipkitės į „Yamaha“ atstovybę savo šaliai. *EEE – Europos ekonominė erdvė	<b>Lietuvių kalba</b>
<b>Dôležité upozornenie: Informácie o záruke pre zákazníkov v EHP* a Švajčiarsku</b> Podrobné informácie o záruke týkajúce sa tohto produktu od spoločnosti Yamaha a garančnom servise v EHP* a Švajčiarsku nájdete na webovej stránke uvedenej nižšie (na našej webovej stránke je k dispozícii súbor na tlač) alebo sa obráťte na zástupcu spoločnosti Yamaha vo svojej krajine. * EHP: Európsky hospodársky priestor	<b>Slovenčina</b>
<b>Pomembno obvestilo: Informacije o garanciji za kupce v EGP* in Švici</b> Za podrobnejše informacije o tem Yamahinem izdelku ter garancijskem servisu v celotnem EGP in Švici, obiščite spletno mesto, ki je navedeno spodaj (natisljiva datoteka je na voljo na našem spletnem mestu), ali se obrnite na Yamahinega predstavnika v svoji državi. * EGP: Evropski gospodarski prostor	<b>Slovenščina</b>
<b>Важно съобщение: Информация за гаранцията за клиенти в ЕИП* и Швейцария</b> За подробна информация за гаранцията за този продукт на Yamaha и гаранционното обслужване в паневропейската зона на ЕИП* и Швейцария или посетете посочения по-долу уеб сайт (на нашия уеб сайт има файл за печат), или се свържете с представителния офис на Yamaha във вашата страна. * ЕИП: Европейско икономическо пространство	<b>Български език</b>
<b>Notificare importantă: Informații despre garanție pentru clienții din SEE* și Elveția</b> Pentru informații detaliate privind acest produs Yamaha și serviciul de garanție Pan-SEE* și Elveția, vizitați site-ul la adresa de mai jos (fișierul imprimabil este disponibil pe site-ul nostru) sau contactați biroul reprezentanței Yamaha din țara dumneavoastră. * SEE: Spațiul Economic European	<b>Limba română</b>
<b>Važna obavijest: Informacije o jamstvu za države EGP-a i Švicarske</b> Za detaljne informacije o jamstvu za ovaj Yamahin proizvod te jamstvenom servisu za cijeli EGP i Švicarsku, molimo Vas da posjetite web-stranicu navedenu u nastavku ili kontaktirate ovlaštenog Yamahinog dobavljača u svojoj zemlji. * EGP: Evropski gospodarski prostor	<b>Hrvatski</b>

<https://europe.yamaha.com/warranty/>

# Yamaha Worldwide Representative Offices

## English

For details on the product(s), contact your nearest Yamaha representative or the authorized distributor, found by accessing the 2D barcode below.

## Deutsch

Wenden Sie sich für nähere Informationen zu Produkten an eine Yamaha-Vertretung oder einen autorisierten Händler in Ihrer Nähe. Diese finden Sie mithilfe des unten abgebildeten 2D-Strichcodes.

## Français

Pour obtenir des informations sur le ou les produits, contactez votre représentant ou revendeur agréé Yamaha le plus proche. Vous le trouverez à l'aide du code-barres 2D ci-dessous.

## Español

Para ver información detallada sobre el producto, contacte con su representante o distribuidor autorizado Yamaha más cercano. Lo encontrará escaneando el siguiente código de barras 2D.

## Português

Para mais informações sobre o(s) produto(s), fale com seu representante da Yamaha mais próximo ou com o distribuidor autorizado acessando o código de barras 2D abaixo.

## Italiano

Per dettagli sui prodotti, contattare il rappresentante Yamaha o il distributore autorizzato più vicino, che è possibile trovare tramite il codice a barre 2D in basso.

## Nederlands

Neem voor meer informatie over de producten contact op met uw dichtstbijzijnde Yamaha-vertegenwoordiger of de geautoriseerde distributeur, te vinden via de onderstaande 2D-barcode.

## Polski

Aby uzyskać szczegółowe informacje na temat produktów, skontaktuj się z najbliższym przedstawicielem firmy Yamaha lub autoryzowanym dystrybutorem, którego znajdziesz za pośrednictwem poniższego kodu kreskowego 2D.

## Русский

Чтобы узнать подробнее о продукте (продуктах), свяжитесь с ближайшим представителем или авторизованным дистрибьютором Yamaha, воспользовавшись двухмерным штрихкодом ниже.

## Dansk

Hvis du vil have detaljer om produktet/produkterne, kan du kontakte den nærmeste Yamaha-repræsentant eller autoriserede Yamaha-distributør, som du finder ved at scanne 2D-stregkode nedenfor.

## Svenska

Om du vill ha mer information om produkterna kan du kontakta närmaste Yamaha-representant eller auktoriserade distributör med hjälp av 2D-streckkoden nedan.



[https://manual.yamaha.com/mi/address\\_list/](https://manual.yamaha.com/mi/address_list/)

## Čeština

Podrobnosti o produktu(ech) získáte od nejbližšího zástupce společnosti Yamaha nebo autorizovaného distributora, který by byl nalezen při použití 2D čárového kódu níže.

## Slovenčina

Podrobné informácie o produkte(-och) vám poskytne najbližší zástupca spoločnosti Yamaha alebo autorizovaný distribútor, ktorého nájdete pomocou nižšie uvedeného 2D čiarového kódu.

## Magyar

A termék(ek)re vonatkozó részletekért forduljon a legközelebbi Yamaha képviselőhöz vagy a hivatalos forgalmazóhoz, amelyet az alábbi 2D vonalkód segítségével találhat meg.

## Slovenščina

Če želite podrobnejše informacije o izdelkih, se obrnite na najbližjega Yamahinega predstavnika ali pooblaščenega distributerja, ki ga najdete prek 2D-kode v nadaljevanju.

## Български

За подробности относно продукта/ите се свържете с най-близкия представител на Yamaha или оторизиран дистрибутор, който можете да откриете, като използвате 2D баркода по-долу.

## Română

Pentru detalii privind produsele, contactați cel mai apropiat reprezentant Yamaha sau distribuitorul autorizat, pe care îl puteți găsi accesând codul de bare 2D de mai jos.

## Latviešu

Lai iegūtu plašāku informāciju par izstrādājumiem, sazinieties ar tuvāko Yamaha pārstāvi vai pilnvaroto izplatītāju, kuru atradīsiet, izmantojot tālāk pieejamo 2D svītrkodu.

## Lietuvių

Norėdami gauti daugiau informacijos apie gaminių (-ius), kreipkitės į artimiausią „Yamaha“ atstovą arba įgaliotąjį platintoją, kurį rasite nuskaityt toliau pateiktą 2D brūkšninį kodą.

## Eesti

Toodete kohta täpsema teabe saamiseks võtke ühendust lähima Yamaha esindaja või autoriseeritud levitajaga, kelle leiате allpool asuva 2D-võõtkoodi kaudu.

## Hrvatski

Za detalje o proizvodima obratite se lokalnom predstavku ili ovlaštenom distributeru tvrtke Yamaha, kojeg možete pronaći skeniranjem 2D crtičnog koda u nastavku.

## Türkçe

Ürünler hakkında ayrıntılar için, aşağıdaki 2D kodlu motora erişerek bulunan size en yakın Yamaha temsilcisine veya yetkili bayiye başvurun.



YAMAHA CORPORATION

10-1 Nakazawa-cho, Chuo-ku, Hamamatsu, 430-8650 Japan

© 2025 Yamaha Corporation  
Published 04/2026  
MWMA-B0



VKH2360