

# YAMAHA SR-30

*Natural Sound Processing Amplifier  
Surround Stereo and Simulated Stereo Processing  
Bass Extension Control, Switchable High Filter  
Dual Speaker Outputs, Dual Monaural Outputs  
Tape Loop with Tape Monitor Switch  
30 Watts RMS per Channel, 8 ohms, 0.01% THD*

*Thank you for purchasing the YAMAHA SR-30 Processing amplifier.*

## CONTENTS

CAUTION	2
FRONT PANEL PARTS AND THEIR FUNCTIONS	3
REAR PANEL PARTS AND THEIR FUNCTIONS	4
CONNECTIONS	5/6
HOW TO USE AND ENJOY THE SR-30	6
SPEAKER PLACEMENT	7
USING THE REAR AND MAIN IN TERMINALS	8
TROUBLESHOOTING	9
BLOCK DIAGRAM	10
SPECIFICATIONS	10



## OWNER'S MANUAL



### IMPORTANT!

Please record the serial number of your unit in the space below.

Model **SR-30**

Serial No. \_\_\_\_\_

The serial number is located on the rear of the unit.

Retain this Owner's Manual in a safe place for future reference.

### WARNING

To prevent fire or shock hazard, do not expose this appliance to rain or moisture.

## SAFETY INSTRUCTIONS

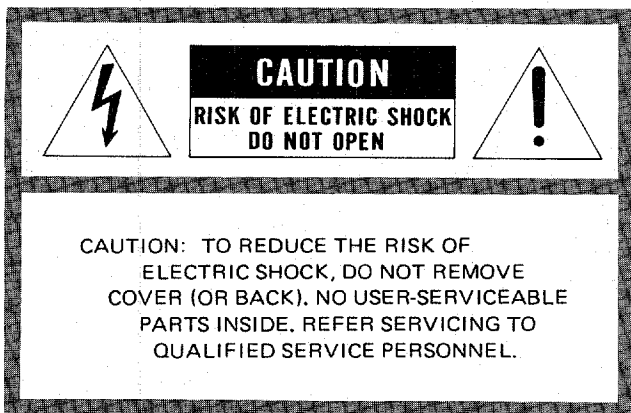

### • Explanation of Graphical Symbols



The lightning flash with arrowhead symbol, within an equilateral triangle, is intended to alert you to the presence of uninsulated "dangerous voltage" within the product's enclosure that may be of sufficient magnitude to constitute a risk of electric shock to persons.



The exclamation point within an equilateral triangle is intended to alert you to the presence of important operating and maintenance (servicing) instructions in the literature accompanying the appliance.

- 1** Read Instructions — All the safety and operating instructions should be read before the appliance is operated.
- 2** Retain Instructions — The safety and operating instructions should be retained for future reference.
- 3** Heed Warnings — All warnings on the appliance and in the operating instructions should be adhered to.
- 4** Follow Instructions — All operating and other instructions should be followed.
- 5** Water and Moisture — The appliance should not be used near water — for example, near a bathtub, washbowl, kitchen sink, laundry tub, in a wet basement, or near a swimming pool, etc.
- 6** Carts and Stands — The appliance should be used only with a cart or stand that is recommended by the manufacturer.
- 7** Wall or Ceiling Mounting — The appliance should be mounted to a wall or ceiling only as recommended by the manufacturer.
- 8** Ventilation — The appliance should be situated so that its location or position does not interfere with its proper ventilation. For example, the appliance should not be situated on a bed, sofa, rug, or similar surface that may block the ventilation openings; or placed in a built-in installation, such as a bookcase or cabinet that may impede the flow of air through the ventilation openings.
- 9** Heat — The appliance should be situated away from heat sources such as radiators, stoves, or other appliances that produce heat.
- 10** Power Sources — The appliance should be connected to a power supply only of the type described in the operating instructions or as marked on the appliance.
- 11** Power-Cord Protection — Power-supply cords should be routed so that they are not likely to be walked on or pinched by items placed upon or against them, paying particular attention to cords at plugs, convenience receptacles, and the point where they exit from the appliance.
- 12** Cleaning — The appliance should be cleaned only as recommended by the manufacturer.
- 13** Nonuse Periods — The power cord of the appliance should be unplugged from the outlet when left unused for a long period of time.
- 14** Object and Liquid Entry — Care should be taken so that objects do not fall into and liquids not spilled into the inside of the appliance.
- 15** Damage Requiring Service — The appliance should be serviced by qualified service personnel when:
  - A. The power-supply cord or the plug has been damaged; or
  - B. Objects have fallen, or liquid has been spilled into the appliance; or
  - C. The appliance has been exposed to rain; or
  - D. The appliance does not appear to operate normally or exhibits a marked change in performance; or
  - E. The appliance has been dropped, or the cabinet damaged.
- 16** Servicing — The user should not attempt to service the appliance beyond those means described in the operating instructions. All other servicing should be referred to qualified service personnel.

**CAUTION: READ THIS BEFORE OPERATING YOUR SR-30**

1

The SR-30 is a sophisticated surround processing amplifier. To ensure proper operating for the best possible operation, please read this manual carefully.

2

Install your SR-30 carefully. Avoid placing it in direct sunlight or close to a source of heat. Also avoid locations subject to vibration and excessive dust, heat, cold or moisture. Keep away from sources of hum such as transformers or motors.

3

Do not open the cabinet as this might result in damage to the set or electrical shock. If a foreign object should get into the set, contact your dealer.

4

When removing the power plug from the wall outlet, always pull directly on the plug; never yank the cord.

5

Do not use force when using the switches, buttons, or knobs.

6

When moving the set be sure to first pull out the power plug and remove cords connecting to other equipment.

7

Always turn the volume knob down before source selection and play back.

8

Do not attempt to clean the SR-30 with chemical solvents as this might damage the finish. Use a clean, dry cloth.

9

Be sure to read the "TROUBLESHOOTING" section for advice on common operating errors before concluding that your SR-30 is faulty.

10

Keep this manual in a safe place for future reference.

11

Do not connect audio equipment to the AC outlets on the rear panel if that equipment requires more power than the outlets are rated to provide.

# SR-30

## FRONT PANEL PARTS AND THEIR FUNCTIONS

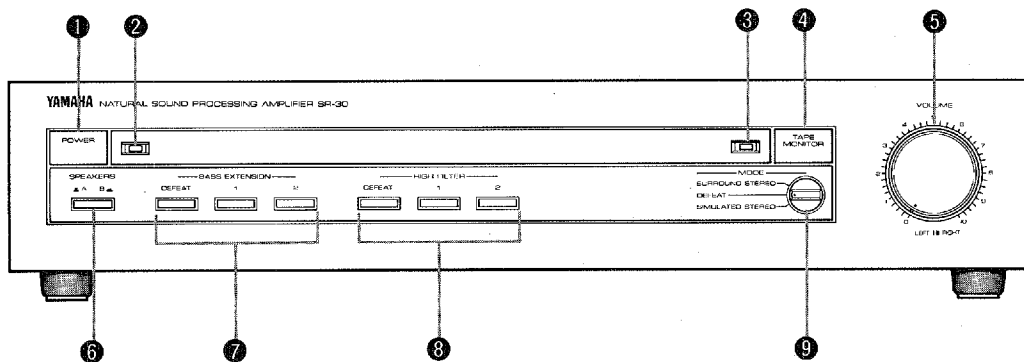

### 1 POWER SWITCH

Turns power on and off. When power is turned on, speaker protection circuitry is activated, muting output for a few seconds to prevent amplification of power-on "popping" noise through your speakers.

### 2 POWER INDICATOR

Lights when power is on.

### 3 TAPE MONITOR INDICATOR

Lights when Tape Monitor switch is engaged.

### 4 TAPE MONITOR SWITCH

Acts as an input source selector, allowing you to monitor playback from a tape deck connected to the rear panel tape deck terminals when engaged.

### 5 VOLUME CONTROL

Provides independent control of left and right channel volume for the speakers connected to the rear panel.

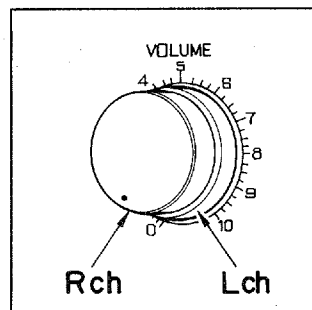

### 6 SPEAKER SELECTOR

Selects either of two speaker pairs which can be connected to the rear panel. Speaker pair A is selected when the button is not depressed; speaker pair B is selected when the button is depressed.

### 7 BASS EXTENSION SELECTORS

The Bass Extension selectors allow you to emphasize low-frequency output to both the "surround" speakers connected to the rear panel, and to the "front" speakers connected to your system amplifier. There are two Bass Extension selectors, and a Defeat selector. Selector 1 boosts output level by 8 dB at the 50 Hz level, for extreme low-frequency emphasis, and Selector 2 boosts output level by 8 dB at the 100 Hz level, for low-frequency emphasis at a level still beneath that of your system amplifier's bass tone control.

### 8 HIGH FILTER SELECTORS

Two High Filter selectors are provided to aid in eliminating high-frequency noise and hiss from the audio signal. High-frequency noise is common with many monaural video and TV program sources. There are two High Filter selectors, and a Defeat selector. Selector 1 cuts out the audio signal from the 5 kHz frequency level and above, for extreme filtering, and Selector 2 cuts out the audio signal from the 10 kHz frequency level and above, for normal high-frequency filtering.

### 9 MODE SELECTOR

This selects either Surround Stereo processing, Simulated Stereo processing, or normal stereo output (Defeat). Please refer to the appropriate portions of this manual for a detailed discussion of Surround Stereo and Simulated Stereo processing.

## REAR PANEL PARTS AND THEIR FUNCTIONS

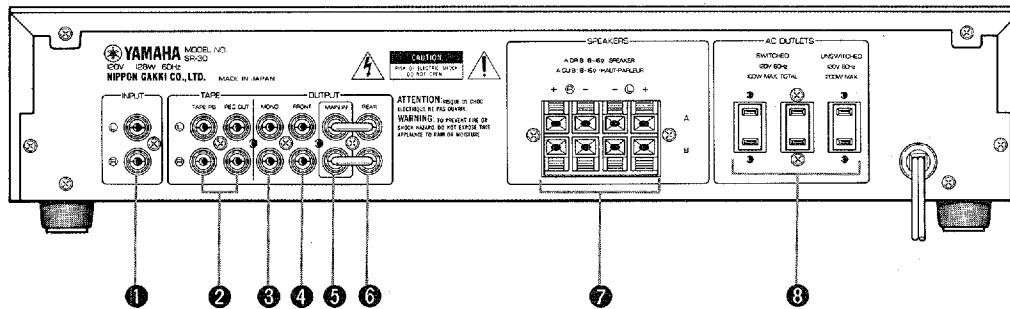

### 1 INPUT

The left and right input terminals receive the audio signal for Surround Stereo or Simulated Stereo processing by the SR-30. Please refer to the Connections portion of this manual for a detailed description of connections to these terminals.

### 2 TAPE PB AND TAPE REC OUT

These terminals allow you to connect a tape deck directly to the SR-30. This does not allow you to record a signal processed in Surround Stereo or Simulated Stereo. It does, however, add an additional tape loop to your entire system, and replaces the one lost if the SR-30 is connected to an amplifier through a tape loop. See Connections.

### 3 MONO

These output terminals allow you to send a two-channel monaural signal to an additional power amplifier for superwoofer or center speaker drive. The monaural signal is unaffected by Surround Stereo or Simulated Stereo processing.

### 4 FRONT

These output terminals fold the signal received at the INPUT terminals back to your system's amplifier, for "front" speaker drive. Simulated Stereo processing, Bass Extension and High Filter settings will affect this signal—Surround Stereo processing will not.

### 5 MAIN IN

These input terminals accept an audio signal from an external preamplifier, allowing you to use the SR-30 simply as a 30 watt stereo power amplifier. In combination with the REAR terminals, they also open up a number of exciting expansion possibilities, allowing you to add in a graphic equalizer, delay unit, or multi-amp/multi-speaker system setup. Normally, these terminals are "defeated" by jumper bars which connect them to the REAR terminals.

### 6 REAR

These output terminals send the output stage signal to an external stereo power amplifier, for higher power amplification if so desired. In combination with the MAIN IN terminals, they also open up a number of exciting

expansion possibilities, allowing you to add in a graphic equalizer, delay unit, or multi-amp/multi-speaker system setup. Normally, these terminals are "defeated" by jumper bars which connect them to the MAIN IN input terminals.

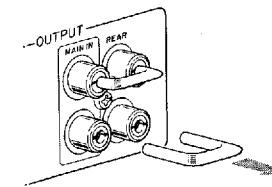

When not using the MAIN IN and REAR terminals, always leave the supplied jumper bars connected. When using either of these terminals, simply pull the jumper bars out.

Pull the jumper bar to remove

### 7 SPEAKERS

Two sets of speaker terminals are provided for connection of speakers. Although two sets of speakers may be connected at the same time, only one pair may be selected for output.

- \*Always be sure that the power is OFF when connecting the speakers to the SR-30.
- \*Beware that the speaker cord never causes shorts.

### 8 AC OUTLETS (U.S.A., Canadian and general models)

Three auxiliary AC power outlets are provided to facilitate easier system power supply connections. The 2 Switched outlets provide power to the component connected only when the SR-30 Power switch is turned on. The 1 Unswitched outlet provides power to the component connected regardless of the SR-30 Power switch. Please observe the maximum wattage limits of these outlets. (Switched: maximum 100 watts total. Unswitched: maximum 200 watts.)

# SR-30

## CONNECTIONS

### BASIC SYSTEM REQUIREMENTS

The SR-30 does not replace your system's amplifier or receiver; it is an additional processing amplifier that connects in the same way a graphic equalizer does. An additional pair of "rear" speakers will be necessary to create the surround sound effect in your listening environment; these are connected to the rear panel of the SR-30, and are powered by the SR-30. The "Front" speakers in your existing system are connected to and powered by your current amplifier or receiver.

### BASIC SYSTEM CONNECTIONS

The rear panel INPUT terminals receive the signal from your amplifier or receiver for processing, and the FRONT terminals send the signal back to the amplifier or receiver, completing the loop. INPUT and FRONT terminals connect to your amplifier or receiver in three possible ways, according to the type of amplifier or receiver you have.

#### 1. Between a Separate Preamplifier and Power Amplifier

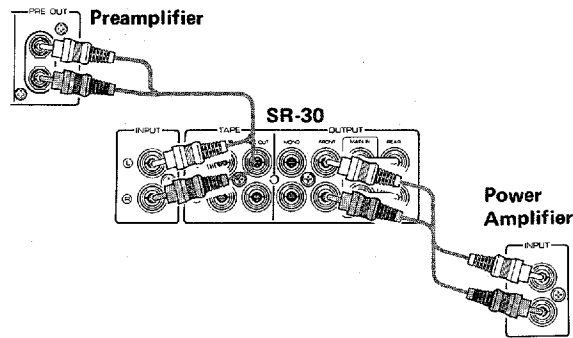

This is the simplest connection. The PRE-OUT terminals of the preamplifier connect to the INPUT terminals on the SR-30. The SR-30 FRONT terminals connect to the INPUT terminals on the power amplifier.

**Note:** Before making any connections, make sure power to all components in your system is turned off. When making connections between components, take care in matching left and right channels accurately.

#### 2. Through a Tape Loop (Integrated Amplifier or Receiver)

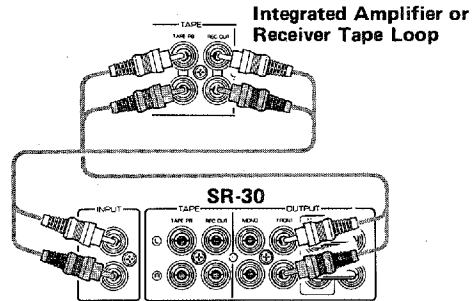

This is the only way to connect the SR-30 to an integrated amplifier or receiver that does not provide special terminals (e.g. "Accessory Output Loop" or "Pre-Main Coupling") for external signal processing. The inputs and outputs for connection of a tape deck are used to connect the SR-30. The REC OUT terminals on the amplifier or receiver connect to the INPUT terminals on the SR-30, and the TAPE PB terminals on the amplifier or receiver connect to the FRONT terminals on the SR-30.

When connections are made in this way, you will have to engage the amplifier or receiver Tape Monitor selector for the terminals connected to the SR-30 in order to receive the signal back from the SR-30.

If your amplifier or receiver has a Rec Out Selector as many Yamaha models do, you will have to use it to send an input source (phono, tuner, CD, AUX, etc.) to the SR-30, and engage the TAPE input selector for the terminals connected to the SR-30 in order to receive the signal back from the SR-30. In other words, the Rec Out Selector then functions as an input source selector.

(See CONNECTING A TAPE DECK TO THE SR-30.)

#### 3. Through a Signal Processing Loop (Integrated Amplifier or Receiver)

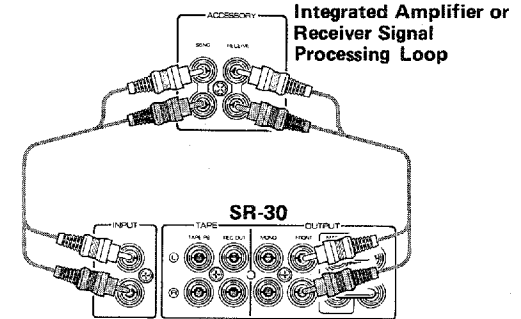

Many new Yamaha integrated amplifiers and receivers are provided with a rear panel Accessory Output Loop which sends and receives a source signal for external processing by a graphic equalizer or sound processor like the SR-30. Such terminals are sometimes referred to as "Pre-Main Coupling" terminals on other components. If your integrated amplifier or receiver has such terminals, simply connect the SEND (or OUT) terminals to the INPUT terminals on the SR-30, and connect the RECEIVE (or IN) terminals to the FRONT terminals on the SR-30. The signal sent to the SR-30 is then selected by the amplifier or receiver's input selector.

### CONNECTING A TAPE DECK TO THE SR-30

If you have connected the SR-30 to an integrated amplifier or receiver through a tape loop, then you can not use that tape loop for its intended purpose—a tape deck. However, the SR-30 has its own tape loop, restoring the one lost when such connections are made, or providing an additional tape loop if connections are made in another way. The SR-30 rear panel tape loop terminals are identical to those on an amplifier or receiver, and they connect to a tape deck in the same way. (Refer to your tape deck owner's manual.)

When you connect a tape deck to the SR-30 in this way, the front panel Tape Monitor Selector serves as an input selector for that tape deck, and routes the playback signal to your amplifier or receiver for monitoring. The source signal received by the SR-30 from your amplifier or receiver may be recorded by the tape deck, unaffected by SR-30 processing.

If the SR-30 is connected through a tape loop to an integrated amplifier or receiver with a Rec Out selector any tape deck previously connected there should be connected to the SR-30 tape loop, not an additional tape loop on the amplifier or receiver.

## CONNECTING SPEAKERS

Speaker connections are the same as those made on a normal amplifier or receiver. The SR-30 has terminals for connection of two pairs of speakers, selectable by a front panel selector. Only one pair of speakers may be selected at a time. With two different pairs of speakers, at different locations in the room, simple A/B comparisons can be made to aid in determining the ideal speaker arrangement. Different speaker pairs may also be permanently located to create a different effect with different program sources.

## MONO OUTPUT CONNECTIONS

A two-channel monaural signal is output at the MONO terminals, permitting superwoofer or center mono speaker drive for added enhancement of the audio/video listening environment. The output signal is a line level signal, equivalent to that from a playback source component, and an additional power amplifier is necessary to power this signal to a superwoofer or center mono speaker. These terminals connect to the INPUT terminals of a separate stereo power amplifier, or to the AUX, TUNER, CD or TAPE PB terminals of an integrated amplifier. (Refer to your amplifier's owner's manual.)

## MAIN IN AND REAR CONNECTIONS

Please refer to the end portion of this manual for a detailed discussion on how these terminals may be used to expand your system capabilities.

## HOW TO USE AND ENJOY THE SR-30

### SURROUND STEREO

With your existing audio system driving a front pair of speakers, and the SR-30 driving an additional pair of rear speakers, you have a surround sound stereo system. The added depth, impact and imaging of surround sound processing creates a dramatic listening experience that rivals that of a live concert or theater setting. A number of different effects can be achieved with different rear speaker placement possibilities. When the SR-30 is used with an integrated audio/video system, the surround stereo mode is particularly effective with stereo video sources.

Unlike other surround processing amplifiers, no delay circuitry is used in the SR-30 Surround Stereo circuit, resulting in a more natural effect.

1. Turn volume all the way down.
2. Make sure the Tape Monitor Selector is off.
3. Set the Mode selector to Surround Stereo.
4. Adjust the volume level to the rear speakers to an appropriate level.

With the surround speakers in the rear, lowering the volume slightly below that of the front speakers creates the most natural effect.

### SIMULATED STEREO

The Simulated Stereo circuit converts a monaural audio signal into a simulated stereo signal with the use of a special comb filter. An optimally determined number of bands, band frequencies, and bandwidth configuration of the filter ensure the most natural response possible. Simulated Stereo is ideal for the audio portion of monaural video and monaural TV sources, adding impact and depth to the sound source. The signal processed with Simulated Stereo is fed back to the front speakers and to the rear speakers if desired.

1. Turn volume all the way down.
2. Make sure the Tape Monitor Selector is off.
3. Set the Mode Selector to Simulated Stereo.
4. Adjust the volume level of the front speakers to an appropriate level (also the rear speakers if they are used).

### HIGH FILTER

The High Filter is particularly effective with video and TV sources, as they are prone to high-frequency noise. When used in combination with the Simulated Stereo effect, poor quality monaural video and TV programs will be dramatically improved.

### BASS EXTENSION

The Bass Extension selectors let you add low-frequency emphasis for audio or video sources that are lacking in bass response. This is particularly effective with video programs that have exciting sound effects, creating a dramatically "live" effect.

# SR-30

## SPEAKER PLACEMENT

### 1. Rear Speaker Placement

In the conventional rear speaker configuration, the pair of speakers connected to the SR-30 speaker output terminals are placed behind the listener with the "right" rear speaker directly behind the right front speaker, and the "left" rear speaker directly behind the left front speaker. The rear speakers should be approximately the same distance apart as the front speakers. The rear speakers should also be approximately the same distance from the listener as the front speakers. This arrangement completely immerses the listener in the sound field, and is generally the most dramatic surround effect.

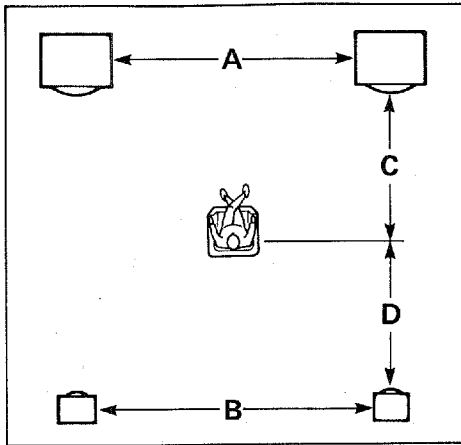

A = B

C = D

### 2. Side Speaker Placement

This alternative speaker arrangement has the effect of dramatically broadening the sound field and placing the listener at the "edge" of the stage. The surround speakers are placed directly to the left and right of the listening position or slightly ahead of the listening position. If you feel too "immersed" in the sound with this arrangement, the surround speakers can be moved even further forward—flanking the front speakers—thus moving the listener away from the "stage" while still providing a greatly broadened sound field.

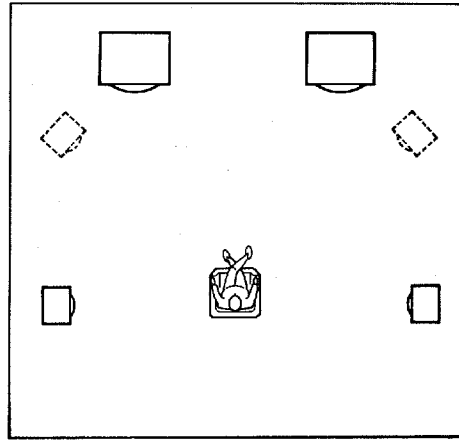

### 3. Front Reflective Placement

In this configuration the surround speakers are aimed at a reflective surface (wall) from beside the front stereo speakers. This has the effect of giving the sound field greater depth. In other words, rather than hearing a two-dimensional sound field from the main stereo speakers, the stage seems to recede behind the main speakers. The effectiveness of this arrangement will depend on the type of surface available behind the front speakers. A soft surface—such as a curtain—will absorb a considerable amount of the surround sound, thus reducing the effect. A fairly hard, even surface is recommended.

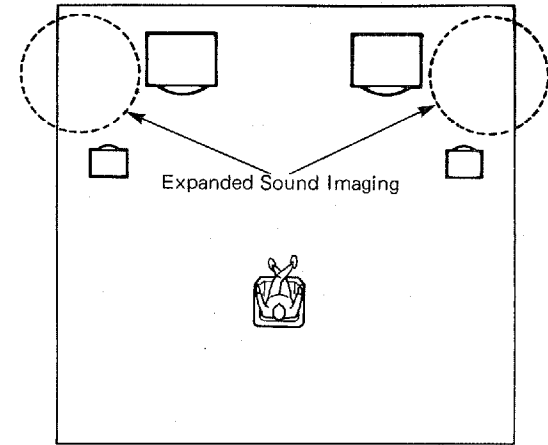



**USING THE REAR AND MAIN IN TERMINALS****1. Extra Signal Processing**

By inserting a stereo graphic equalizer in the SR-30 surround sound signal path—the REAR terminals feed the INPUTS of the graphic equalizer, and the OUTPUTS from the equalizer feed the SR-30 MAIN IN terminals—it is possible to further tailor the frequency characteristics of the surround sound for greater effect. You might want to emphasize only the lower frequency components of the surround sound, for example, to limit the surround effect to sounds in this frequency range: spaceships or planes rumbling overhead, gunfights, etc. By emphasizing the middle-high frequencies you would enhance the surround effect on waves, wind, and other “environmental” sounds. The possibilities are virtually limitless.

Another possibility for external signal processing is to insert a stereo delay unit in place of the graphic equalizer as described above (you could even combine the two). Delaying the surround sound (between about 10 to 50 milliseconds delay) has the effect of greatly enlarging the listening room, making it seem as though you are listening in an extremely large hall.

The SR-30 REAR and MAIN IN terminals are essentially an “insert” point between the surround processor stage and the SR-30 stereo power amplifier stage. They can be used in a number of ways to produce more sophisticated surround effects, as described below.

**2. Four-Speaker Surround**

This is a really sophisticated setup that delivers surround sound from four speakers simultaneously. Feed the REAR terminals to the inputs of another integrated amplifier (NOT the one that is driving your main speakers), then return the signal from that amplifier’s REC OUT terminals to the SR-30 MAIN IN terminals. This way you have one pair of surround speakers driven by the extra integrated amp and another driven by the SR-30 power amp. You could, for example, place one pair of surround speakers behind you, and another off to the sides or facing the wall next to the front speakers in order to reflect the surround sound (see SPEAKER PLACEMENT section). You could even insert equalization between the RED OUT terminals of the integrated amp and the SR-30 MAIN IN terminals so that the two pairs of surround speakers deliver a different portion of the surround signal frequency spectrum. Delay could also be incorporated so that one surround sound speaker pair (preferably the rear speakers) delivers a delayed surround sound in relation to the other pair.

**3. High-Power Surround**

Although this will seldom be the case, the SR-30’s internal power amplifier may not have enough power to produce the desired surround effect in very large rooms in which the surround speakers are placed a considerable distance from the listener. This would be the case in a large-screen projection video “theater” for large audiences. In this application the buss bars connecting the REAR and MAIN IN terminals are removed, and the REAR terminals are connected to the inputs of a high-wattage power amplifier or integrated amplifier, which then drives the surround speakers. The SR-30 power stage is not used.

# SR-30

## TROUBLESHOOTING

Before assuming that there is a problem with your SR-30, please consult the following list of possible problems and corrective measures you can make yourself without having to call a service engineer. If you have any doubts or questions, please get in touch with your nearest Yamaha dealer.

Fault	Cause	Cure
No power is supplied when the Power switch is turned on.	Power cord connections are improperly made.	Recheck all power cord connections.
		If power is supplied from the rear panel of another component, make sure power to that component is turned on first.
There is no sound from the rear speakers.	SR-30 volume control is turned all the way down.	Raise SR-30 volume control until sound is heard.
	SR-30 Tape Monitor Selector is engaged.	Disengage the SR-30 Tape Monitor Selector.
	Connections between components are not properly made.	Recheck all connections between components.
	Source selection at amplifier or receiver is not properly made.	Check source selection at amplifier or receiver, referring to the Connections portion of this manual.
	SR-30 front panel speaker selection is improperly made.	Select the proper speaker pair (A or B).
There is no sound from the front speakers.	Amplifier or receiver volume control is turned all the way down.	Raise amplifier or receiver volume control until sound is heard.
	SR-30 Tape Monitor selector is engaged.	Disengage the SR-30 Tape Monitor Selector.
	Connections between components are not properly made.	Recheck all connections between components.
	Source selection at amplifier or receiver is not properly made.	Check source selection at amplifier or receiver, referring to the Connections portion of this manual.
There is no sound from one of the rear speakers.	Speaker connections are improperly made.	Recheck speaker connections.
	One channel of the SR-30 volume control is turned all the way down.	Turn both channels of the SR-30 volume control up until sound is heard from both rear speakers.

## BLOCK DIAGRAM

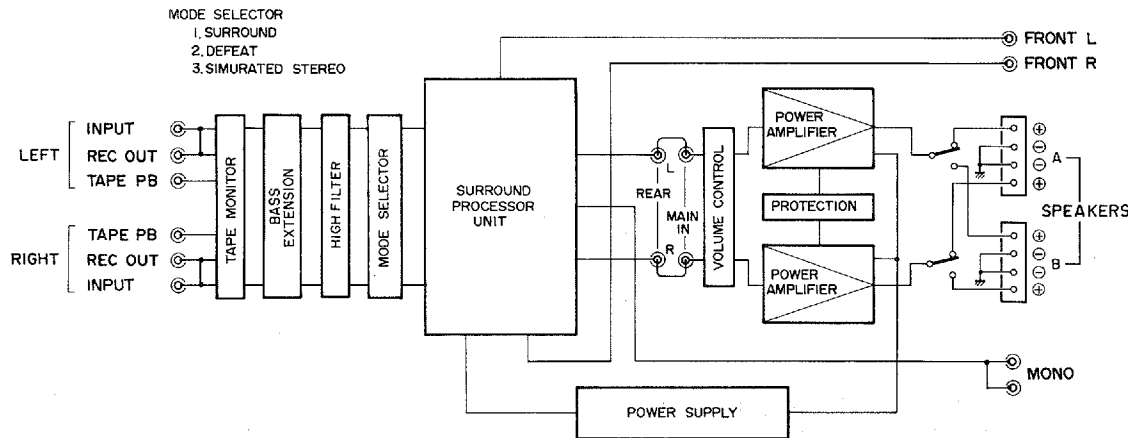

## SPECIFICATIONS

### ■ SURROUND PROCESSOR

Input Sensitivity	150mV
Output level/Impedance	
FRONT, REAR	150mV/1k $\Omega$
MONO	150mV/5k $\Omega$
Maximum Output (FRONT, REAR)	
20 to 20kHz, 1% T.H.D.	9V
Filter Characteristics	
BASS EXTENSION 1	8dB (50Hz)
BASS EXTENSION 2	8dB (100Hz)
HIGH FILTER 1	-12dB/oct (5kHz)
HIGH FILTER 2	-12dB/oct (10kHz)
Mode Selector	
SURROUND STEREO	2ch $\rightarrow$ 4ch
SIMULATED STEREO	monaural $\rightarrow$ 2ch

### ■ POWER AMPLIFIER

Continuous Power Per Channel	
20 to 20kHz, 8 $\Omega$ , 0.01% T.H.D.	30W
1kHz, 8 $\Omega$ , 0.01% T.H.D.	40W
Input Sensitivity/Impedance	150mV/47k $\Omega$
Power Band Width	
8 $\Omega$ , 15W, 0.04% T.H.D.	10 to 50kHz
Frequency Response	
20 to 20kHz	+0 -0.5dB
Signal to Noise Ratio	
Input shorted IHF-A network	105dB
AC OUTLET	
Switched x 2	100W max. total
Unswitched x 1	200W max.
Power Supply	AC120V, 60Hz
Power Consumption	128W
Dimensions (W x H x D)	435 x 92 x 293 mm (17-1/8" x 3-5/8" x 11-1/2")
Weight	4.8 kg (10 lbs. 6 oz.)
Accessories	2 cords

*\*Specifications subject to change without notice.*

SINCE 1887  **YAMAHA**  
NIPPON GAKKI CO., LTD. HAMAMATSU, JAPAN