

YAMAHA *Clavinova*[®]

CVP-20

**Owner's Guide
Bedienungsanleitung
Manuel d'instructions
Manual del Propietario**

IMPORTANT

Check your power supply

Make sure that your local AC mains voltage matches the voltage specified on the name plate on the bottom panel. In some areas a voltage selector may be provided on the rear panel of the main keyboard unit. Make sure that the voltage selector is set for the voltage in your area.

WICHTIG

Überprüfung der Stromversorgung

Sicherstellen, daß die örtliche Netzspannung den Betriebsspannungswerten entspricht, die in die Plakette auf der Unterseite des Keyboards eingetragen sind. Für manche Bestimmungsländer ist das Keyboard mit einem Spannungswähler auf der Rückseite ausgerüstet. Darauf achten, daß der Spannungswähler auf die örtliche Netzspannung eingestellt ist.

IMPORTANT

Contrôler la source d'alimentation

S'assurer que la tension secteur locale correspond à la tension indiquée sur la plaque d'identification située sur le panneau inférieur. Les modèles destinés à certaines régions peuvent être équipés d'un sélecteur de tension situé sur la plaque d'identification, sur le panneau arrière du clavier. Vérifier que le sélecteur est bien réglé pour la tension secteur utilisée.

IMPORTANTE

Verifique la alimentación de corriente

Asegúrese de que el voltaje local de CA concuerde con el especificado en la placa de identificación del panel trasero. En algunas áreas, la unidad viene provista de un selector de voltaje en el panel inferior de la unidad de teclado principal. Asegúrese de que este selector esté en la posición correspondiente al voltaje de su área.

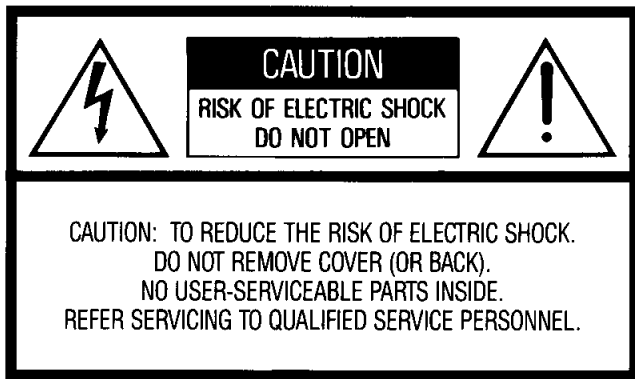

See bottom of keyboard enclosure for graphic symbol markings

Explanation of Graphical Symbols

The lightning flash with arrowhead symbol, within an equilateral triangle, is intended to alert the user to the presence of uninsulated "dangerous voltage" within the product's enclosure that may be of sufficient magnitude to constitute a risk of electric shock to persons.



The exclamation point within an equilateral triangle is intended to alert the user to the presence of important operating and maintenance (servicing) instructions in the literature accompanying the product.



IMPORTANT SAFETY AND INSTALLATION INSTRUCTIONS

INFORMATION RELATING TO POSSIBLE PERSONAL INJURY, ELECTRIC SHOCK, AND FIRE HAZARD POSSIBILITIES HAS BEEN INCLUDED IN THIS LIST.

WARNING — When using electronic products, basic precautions should always be followed, including the following:

1. Read all Safety and Installation Instructions, Explanation of Graphical Symbols, and assembly instructions (where applicable) BEFORE using your Yamaha electronic product. Check unit weight specifications before you attempt to move this instrument!
2. Main Power Supply Verification: Your Yamaha electronic product has been manufactured specifically for the main supply voltage used in your area. If you should move, or if any doubt exists, please contact your dealer for instructions. The main supply voltage required by your electronic product is printed on the name plate. For name plate location, see Before Playing item.
3. This product may be equipped with a polarized line plug (one blade wider than the other). If you are unable to insert the plug into the outlet, contact an electrician to have your obsolete outlet replaced. Do NOT defeat the safety purpose of the plug. Yamaha products not having polarized plugs incorporate construction methods and designs that do not require line plug polarization.
4. **WARNING** — Do NOT place objects on your electronic product's power cord or place the unit in a position where anyone could trip over, walk over, or roll anything over cords of any kind. Do NOT allow your electronic product or its bench to rest on or be installed over cords of any type. Improper installations of this type create the possibility of a fire hazard and/or personal injury.
5. Environment: Your electronic product should be installed away from heat sources such as a radiator, heat registers and/or other products that produce heat. Additionally, the unit should not be located in a position that exposes the cabinet to direct sunlight, or air currents having high humidity or heat levels.
6. Your Yamaha electronic product should be placed so that its location or position does not interfere with its proper ventilation.
7. Some Yamaha electronic products may have benches that are either a part of the product or supplied as an optional accessory. Some of these benches are designed to be dealer assembled. Please make sure that the bench is stable before using it. The bench supplied by Yamaha was designed for seating only. No other uses are recommended.

8. Some Yamaha electronic products can be made to operate with or without the side panels or other components that constitute a stand. These products should be used only with the components supplied or a cart or stand that is recommended by the manufacturer.
9. Do not operate for a long period of time at a high volume level or at a level that is uncomfortable. If you experience any hearing loss or ringing in the ears, you should consult an audiologist.
10. Do not use your Yamaha electronic product near water or in wet environments. For example, near a swimming pool, spa, or in a wet basement.
11. Care should be taken so that objects do not fall, and liquids are not spilled, into the enclosure through openings.
12. Your Yamaha electronic product should be serviced by a qualified service person when:
 - a. The power-supply cord or plug has been damaged: or
 - b. Objects have fallen, or liquid has been spilled into the product: or
 - c. The product has been exposed to rain: or
 - d. The product does not operate, exhibits a marked change in performance: or
 - e. The product has been dropped, or the enclosure of the product has been damaged.
13. When not in use, always turn your Yamaha electronic product "OFF". The power-supply cord of the product should be unplugged from the outlet when it is to be left unused for a long period of time. Notes: In this case, some units may lose some user programmed data. Factory programmed memories will not be affected.
14. Do not attempt to service the product beyond that described in the user-maintenance instructions. All other servicing should be referred to qualified service personnel.
15. Electromagnetic Interference (RFI). This series of Yamaha electronic products utilizes digital (high frequency pulse) technology that may adversely affect Radio/TV reception or the operation of other devices that utilize digital technology. Please read FCC Information (page 67) for additional information.

**PLEASE KEEP THIS MANUAL
FOR FUTURE REFERENCE!**

Introduction

Please accept our thanks for purchasing a Yamaha Clavinova CVP-20. The Clavinova is a completely new type of keyboard made possible by Yamaha's advanced technology and over a century of experience in manufacturing musical instruments.

Its main features are as follows:

- 76 standard size keys
- An AE (Action Effect) keyboard with weighted touch and dynamic control virtually identical to those of an acoustic piano.
- 22 realistic AWM orchestra voices and 32 dynamic rhythms.
- A variety of functions that enable a wide range of performances, including Solo Styleplay, Piano ABC, Keyboard Percussion, Performance and Registration Memories, MIDI compatibility and more.

Einleitung

Vielen Dank für den Kauf eines Yamaha Clavinova CVP-20. Das Clavinova ist eine völlig neue Art Tasteninstrument, ermöglicht durch die fortschrittliche Technologie von Yamaha und über einem Jahrhundert Erfahrung in der Herstellung von Musikinstrumenten. Es zeichnet sich durch die folgenden Merkmale aus:

- 76 Manuallasten in Standardgröße
- Ein AE-(Action Effect)-Manual mit Anschlagdynamik, praktisch identisch zu dem eines akustischen Pianos.
- 22 realistische AWM-Orchesterstimmen und 32 dynamische Rhythmen.
- Eine Vielzahl von Funktionen, die einen großen Bereich an Darbietungen gestatten, darunter Solo Styleplay, Piano ABC, Keyboard Percussion, Performance- und Registrierungs-Speicher, MIDI-Kompatibilität und mehr.

Introduction

Nous tenons à vous remercier d'avoir porté votre choix sur un Clavinova CVP-20. C'est un tout nouveau type d'instrument que seules les techniques de pointe et l'expérience centenaire de Yamaha en matière d'instruments de musique, ont rendu possible. Voici ses principales caractéristiques.

- Soixante-seize touches de dimension standard.
- Un clavier "Action Effect" dont le toucher est pondéré et le contrôle dynamique, reproduisant parfaitement les sensations d'un piano acoustique.
- Vingt-deux voix d'orchestre et 32 rythmes dynamiques.
- Un grand éventail de particularités telles que Solo Styleplay, Piano ABC, les percussions au clavier, les mémoires d'exécution et de registration et la compatibilité MIDI.

Introducción

Permítanos agradecerle sinceramente la compra de este Clavinova Yamaha CVP-20. El Clavinova es un tipo de teclado completamente nuevo, hecho realidad gracias a la avanzada tecnología de Yamaha y a su larga experiencia en la fabricación de instrumentos musicales, que abarca más de un siglo. Sus características principales son las siguientes:

- 76 teclas de tamaño estándar.
- Un teclado AE (Efecto de acción) con toque ponderado y control dinámico, virtualmente idénticos a los de un piano tradicional.
- 32 ritmos dinámicos y 22 voces de orquesta AWM, de gran realismo.
- Amplia variedad de funciones que le permite una gran diversidad de ejecuciones, incluyendo el estilo de ejecución solista, el piano ABC, el teclado de percusión, las memorias de ejecuciones y registro, la compatibilidad MIDI y mucho más.

Contents

	PAGE
• Assembly Instructions	3
• Before Playing	7
• Voice Section	8
• Rhythm Section	10
• Keyboard Percussion	11
• Piano ABC	12
• Solo Styleplay	13
• Performance Memory	13
• Registration Memory	15
• Useful Information	15
• How to Use MIDI	16
• Specifications	67
• MIDI Implementation Chart	68

Inhalt

	Seite
• Zusammenbau-Anleitung	3
• Vor dem Spielen	22
• Stimmen-Sektion	23
• Rhythmus-Sektion	25
• Keyboard Percussion	26
• Piano ABC	27
• Solo Styleplay	28
• Performance-Speicher	28
• Registrierungs-Speicher	30
• Nützliche Information	30
• Verwendung von MIDI	31
• Technische Daten	67
• MIDI-Implementations-tabelle	68

Table des matières

	Page
• Instructions de montage	3
• Avant de jouer	37
• Les voix	38
• Le rythme	40
• Les percussions au clavier	41
• Piano ABC	42
• Solo Styleplay	43
• La mémoire d'exécution	43
• La mémoire de registration	45
• Quelques renseignements utiles	45
• L'interface MIDI	46
• Caractéristiques	67
• Tableau des fonctions MIDI	68

Indice

	PAGINA
• Instrucciones de montaje	3
• Antes de tocar	52
• Sección de las voces	53
• Sección del ritmo	55
• Percusión del teclado	56
• Piano ABC	57
• Estilo de ejecución solista	58
• Memoria de ejecuciones	58
• Memoria de registro	60
• Información útil	60
• Cómo utilizar MIDI	61
• Especificaciones	67
• Tabla de implementación de MIDI	68

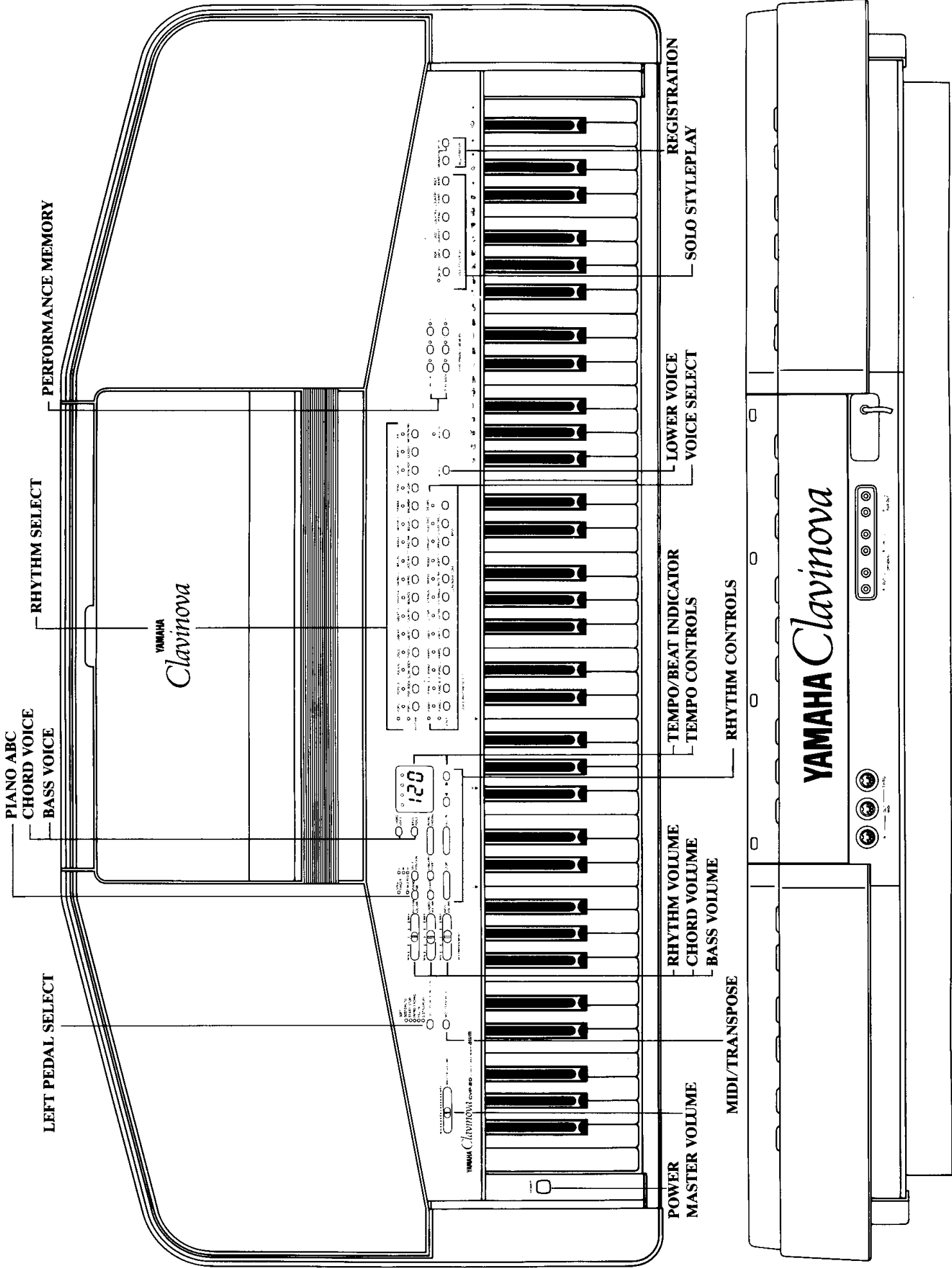

PIANO ABC
 CHORD VOICE
 BASS VOICE

LEFT PEDAL SELECT

RHYTHM SELECT

PERFORMANCE MEMORY

YAMAHA
Clavinova

POWER
 MASTER VOLUME

MIDI/TRANPOSE

RHYTHM VOLUME
 CHORD VOLUME
 BASS VOLUME

TEMPO/BEAT INDICATOR
 TEMPO CONTROLS

RHYTHM CONTROLS

LOWER VOICE
 VOICE SELECT

REGISTRATION
 SOLO STYLEPLAY

YAMAHA
Clavinova

Assembly Instructions
Zusammenbau-Anleitung
Instructions de montage
Instrucciones de montaje

1

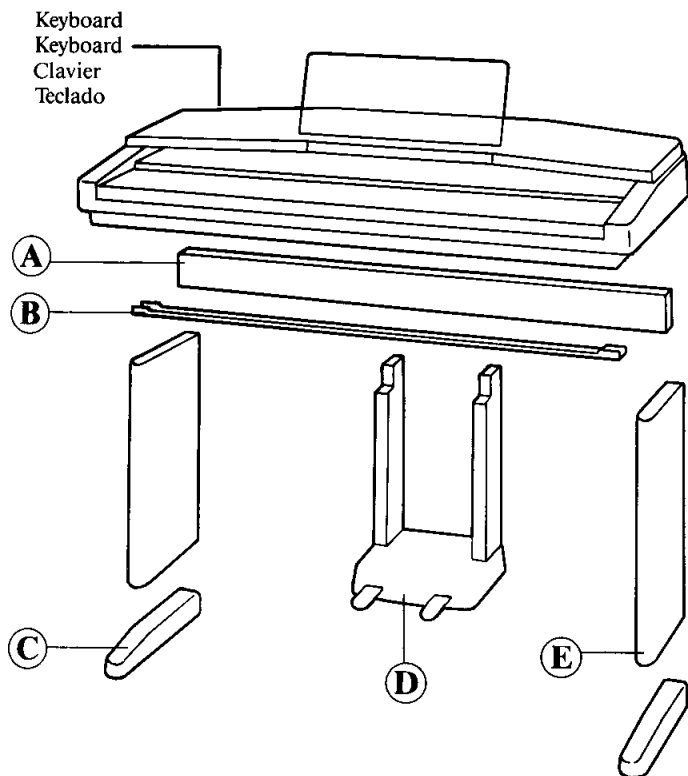

Open the carton and remove the various parts.

When assembling the CVP-20, be sure to have someone help you. Remove all parts, including screws, connectors and caps.

Öffnen Sie den Karton und entnehmen Sie die verschiedenen Teile.

Zum Zusammenbau des CVP-20 benötigen Sie die Hilfe einer weiteren Person. Entnehmen Sie alle Teile, einschließlich Schrauben, Verbindungsstücke und Kappen.

Ouvrez le carton d'emballage et retirez toutes les pièces

Assurez-vous de n'oublier aucune pièce dans l'emballage (veillez aux vis, connecteurs, cache-vis).

Abra la caja y saque todas las piezas.

Pida ayuda a otra persona para montar el CVP-20. Quite todas las piezas, inclusive los tornillos, conectores y tapas.

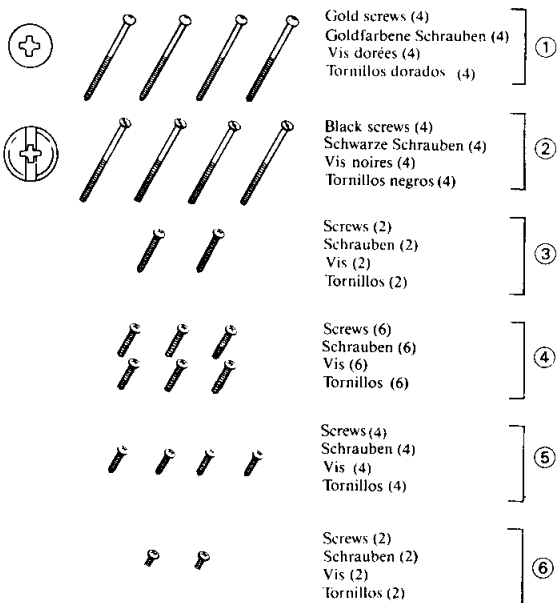

Joint connectors (8)
 Verbindungsstücke (8)
 Ecrous de rappel (8)
 Conectores de unión (8)



Plastic caps (4)
 Plastikkappen (4)
 Cache-vis en plastique (4)
 Tapas de plástico (4)

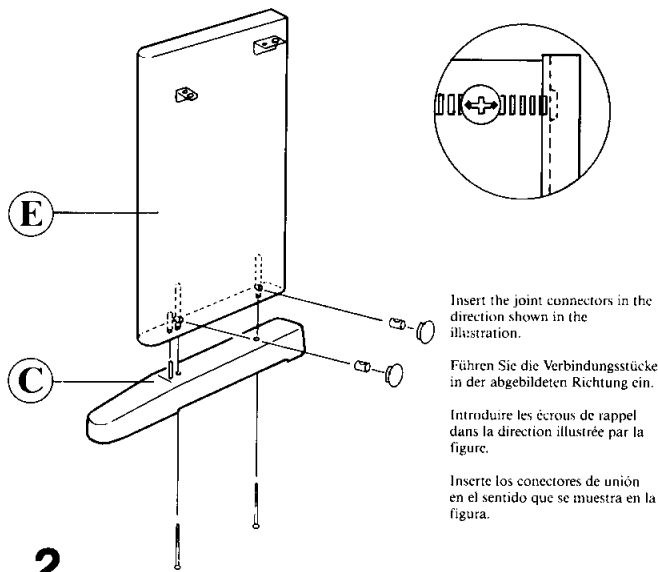

Insert the joint connectors in the direction shown in the illustration.

Führen Sie die Verbindungsstücke in der abgebildeten Richtung ein.

Introduire les écrous de rappel dans la direction illustrée par la figure.

Inserte los conectores de unión en el sentido que se muestra en la figura.

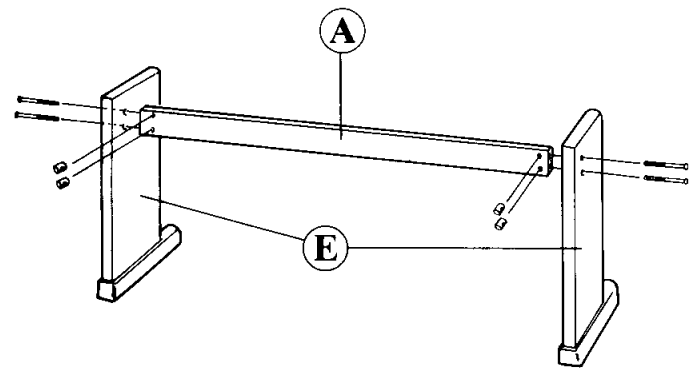

Connect part (A) to parts (E).

Connect part (A) to parts (E), securing part (A) firmly with 4 joint connectors and 4 black screws ② as shown in fig. 3.

Assemble the legs.

As shown in fig. 2, attach each part (C) to one part (E). Place a joint connector into each of the holes at the lower portion of parts (E), and secure parts (C) with 4 gold screws ①. Cover each hole with a plastic cap.

Verbinden Sie Teil (A) mit den Teilen (E).

Verbinden Sie Teil (A) mit den Teilen (E), sichern Sie Teil (A) mit 4 Verbindungsstücken und 4 schwarzen Schrauben ②, siehe Abb. 3.

Bauen Sie die Beine zusammen.

Wie in Abb. 2 gezeigt, bringen Sie jedes Teil (C) an ein Teil (E) an. Stecken Sie ein Verbindungsstück in jede der Löcher unten an den Teilen (E) und sichern Sie die Teile (C) mit 4 goldfarbenen Schrauben ①. Bedecken Sie jedes Loch mit einer Plastikkappe.

Reliez les pièces (A) et (E).

Reliez les pièces (A) et (E) à l'aide des 4 écrous de rappel et des 4 vis noires ②, comme le montre la figure 3.

Montage des pieds

Fixez une pièce (C) à une pièce (E), comme le montre la figure 2. Placez un écrou de rappel dans chaque trou pratiqué à la partie inférieure de la pièce (E) et fixez les pièces (C) au moyen des 4 vis dorées ①. Posez ensuite un cache-vis.

Conecte la pieza (A) a las piezas (E).

Conecte la pieza (A) a las piezas (E), asegurando firmemente la pieza (A) con 4 conectores de unión y 4 tornillos negros ② como se muestra en la figura 3.

Arme las patas.

Como se indica en la fig. 2, junte cada una de las piezas (C) con cada una de las piezas (E). Coloque un conector de unión en cada uno de los orificios de la parte inferior de las piezas (E), y fije las piezas (C) con 4 tornillos dorados ①. Cubra cada uno de los orificios con una tapa de plástico.

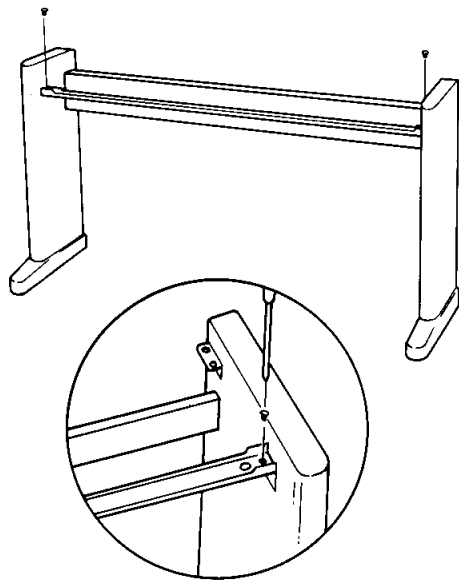

4

Connect part (B) to parts (E).

Connect part (B) to parts (E), securing it firmly with 2 screws ⑥ as shown in fig. 4.

Verbinden Sie Teil (B) mit den Teilen (E).

Verbinden Sie Teil (B) mit den Teilen (E) und sichern es mit 2 Schrauben ⑥, siehe Abb. 4.

Reliez les pièces (B) et (E)

Reliez les pièces (B) et (E) à l'aide des 2 vis ⑥, comme le montre la figure 4.

Conecte la pieza (B) a las piezas (E).

Conecte la pieza (B) a las piezas (E), asegurándola firmemente con dos tornillos ⑥ como se muestra en la figura 4.

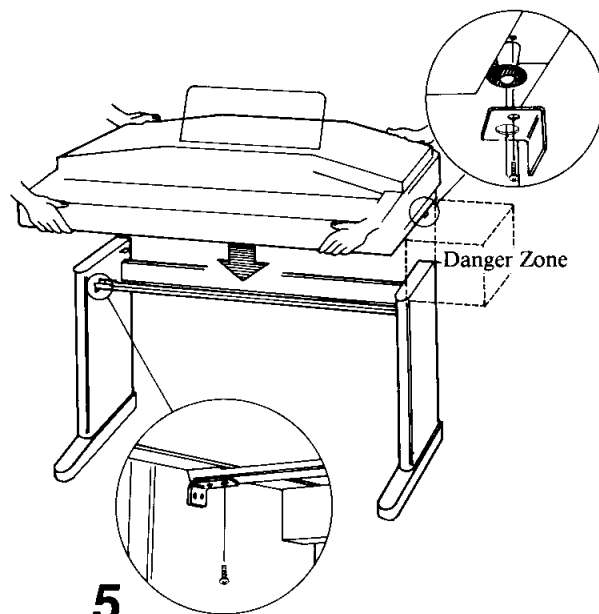

5

Place the keyboard on parts (E).

As shown in fig. 5, gently place the keyboard on parts (E) so that the 2 plastic black cones on the bottom of the keyboard fit into the bigger holes of the back metal fittings. Secure the keyboard by screwing 2 screws ④ into the back metal fittings and 2 screws ③ into the front metal fittings.

Notes:

1. When disassembling the Clavinova unscrew the black cones with a Phillips screwdriver.
2. Be careful not to damage parts (E) when placing the keyboard on them.

Legen Sie das Keyboard auf die Teile (E).

Wie in Abb. 5 gezeigt, legen Sie das Keyboard vorsichtig auf die Teile (E), so daß die 2 schwarzen Plastikkegel an der Unterseite des Keyboards in die größeren Löcher der hinteren Metallbeschläge kommen. Sichern Sie das Keyboard, indem Sie 2 Schrauben ④ in die hinteren Metallbeschläge und 2 Schrauben ③ in die vorderen Metallbeschläge schrauben.

Hinweise:

1. Zum Auseinanderbauen des Clavinova die schwarzen Kegel mit einem Kreuzschlitzschraubendreher losschrauben.
2. Sorgfältig darauf achten, die Teile (E) nicht zu beschädigen, wenn das Keyboard darauf gelegt wird.

Posez le clavier sur les pièces (E).

Posez le clavier sur les pièces (E), comme le montre la figure 5, de manière que les deux cônes en plastique noir situés à la partie inférieure du clavier entrent dans les trous pratiqués dans les ferrures métalliques noires. Fixez le clavier à l'aide de deux vis ④ (ferrures métalliques noires) et des deux vis ③ (ferrures métalliques avant).

Remarques:

1. Pour démonter le Clavinova, dévissez les cônes noirs à l'aide d'un tournevis cruciforme.
2. Veillez à ne pas endommager les pièces (E) lorsque vous posez le clavier.

Coloque el teclado sobre las piezas (E).

Como se muestra en la fig. 5, coloque suavemente el teclado sobre las piezas (E) de forma que los 2 conos de plástico negro situados en la parte inferior del teclado encajen en los orificios mayores de los accesorios de conexión metálicos traseros. Fije el teclado a los accesorios de conexión metálicos traseros con 2 tornillos ④ y a los accesorios de conexión metálicos delanteros con 2 tornillos ③.

Notas:

1. Cuando desmonte el Clavinova, destornille los conos negros con un destornillador tipo Phillips.
2. Tenga cuidado para no dañar las piezas (E) al colocar sobre ellas el teclado.

Do not carry the keyboard by holding onto the area marked Danger Zone in the illustration. Hold the keyboard as shown in fig. 5 to avoid trapping your hands between the keyboard and parts (E).

Das Keyboard nicht an dem mit Gefahrenzone in der Abbildung gekennzeichneten Teil tragen. Das Keyboard wie in Abb. 5 halten, um nicht die Hände zwischen dem Keyboard und den Teilen (E) einzuklemmen.

Ne déplacez pas le Clavinova en le saisissant à l'emplacement indiqué sur l'illustration comme présentant un danger. Saisissez le clavier comme le montre la figure 5 de manière que vos doigts ne puissent être coincés entre le clavier et les pièces (E).

No transporte el teclado sosteniéndolo del área marcada Danger Zone (Zona peligrosa) en la ilustración. Sostenga el teclado como se muestra en la fig. 5 para evitar que su mano quede retenida entre el teclado y las piezas (E).

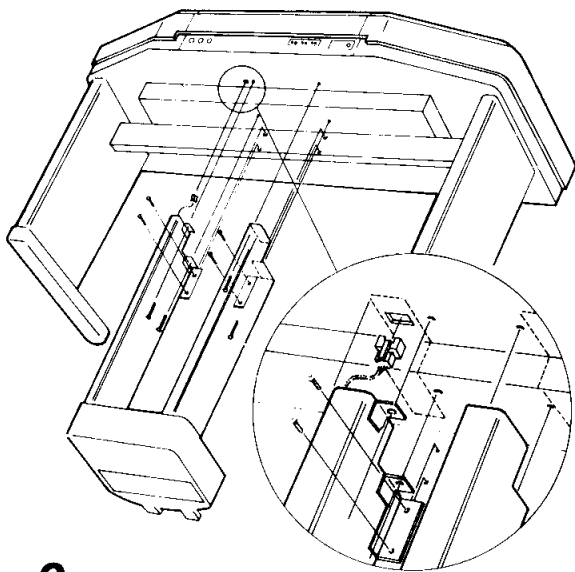

The pedal connector can be inserted in one direction only. (Insert in the direction shown in the illustration.)

Der Pedalstecker kann nur in einer Richtung eingesteckt werden. In die abgebildete Richtung einstecken.

Le connecteur des pédales ne peut être introduit que dans un seul sens, celui représenté par

El conector de los pedales puede insertarse en un sentido solamente. Insertélo en el sentido que se indica en la ilustración

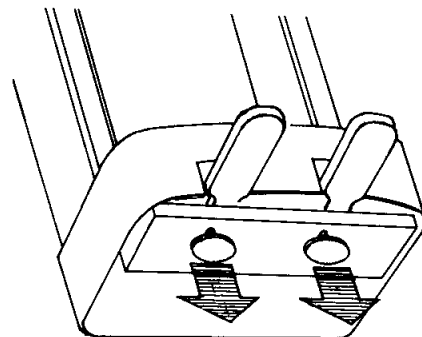

7

Loosen the pedal adjusters

Two pedal adjusters are provided at the bottom of part (D) for stability and pedal length adjustment. Loosen the pedal adjusters so that they touch the floor. This will ensure that part (D) remains stable when pushing down the pedals with your feet, thus enabling more precise pedal control.

* To make sure that all connections have been properly made, check each screw once again for a secure fit.

Lösen Sie die Pedaleinsteller.

An der Unterseite von Teil (D) befinden sich zwei Pedaleinsteller für Stabilitäts- und Pedallängen-Einstellung. Lösen Sie die Pedaleinsteller, so daß sie den Fußboden berühren. Dadurch wird gewährleistet, daß Teil (D) beim Betätigen der Pedale mit dem Fuß stabil bleibt, so daß eine präzisere Pedalbetätigung möglich ist.

* Überprüfen Sie alle Schrauben, um sicherzugehen, daß alle Befestigungen einwandfrei durchgeführt wurden.

Dévissez les régleurs des pédales.

Deux régleurs sont prévus à la partie inférieure de la pièce (D) pour assurer sa stabilité et positionner les pédales en hauteur. Dévissez ces régleurs afin qu'ils viennent en contact avec le sol. De la sorte, la pièce (D) demeure stable, même lorsque vous appuyez sur les pédales.

* Assurez-vous une fois encore que vous avez soigneusement serré toutes les vis.

Afloje los ajustadores de los pedales.

En la parte inferior de la pieza (D) se suministran dos ajustadores de los pedales que brindan estabilidad y permiten regular la longitud de los pedales. Afloje los ajustadores de los pedales de modo que toquen el piso. De esta forma se asegurará que la pieza (D) se mantenga estable cuando se presionen los pedales con el pie, permitiendo un control de los pedales más preciso.

* Para asegurarse de que todas las conexiones se han realizado correctamente, verifique otra vez que todos los tornillos estén bien colocados.

6

Connect part (D).

Connect part (D) to the keyboard as shown in fig. 6. Insert the pedal connector into the socket at the bottom of the keyboard. Align the holes in the metal fittings of part (D) and the holes in the middle of part (A) and at the bottom of the keyboard. First insert and screw 4 screws ⑤ into part (A), then insert and screw 4 screws ④ into the keyboard. It may be necessary to lift part (D) a little while securing. When inserting, make sure that the wire does not get caught between the keyboard and the pedal connector. Push the wire all the way into part (D).

Bringen Sie das Teil (D) an.

Bringen Sie das Teil (D) an das Keyboard an, siehe Abb. 6. Stecken Sie den Pedalstecker in die Buchse an der Unterseite des Keyboards. Richten Sie die Löcher in den Metallbeschlägen von Teil (D) und die Löcher in der Mitte von Teil (A) und an der Unterseite des Keyboards miteinander aus. Schrauben Sie zuerst 4 Schrauben ⑤ in Teil (A) und dann 4 Schrauben ④ in das Keyboard. Zum Sichern kann es erforderlich sein, das Teil (D) etwas anzuheben.

Beim Einstecken des Pedalsteckers darauf achten, daß der Draht nicht zwischen dem Keyboard und dem Pedalstecker eingeklemmt wird. Den Draht vollständig in Teil (D) einschieben.

Fixez la pièce (D).

Fixez la pièce (D) au clavier, comme le montre la figure 6. Introduisez le connecteur de la pédale dans la prise située à la partie inférieure du clavier. Superposez les trous des ferrures métalliques de la pièce (D) et les trous situés au milieu de la pièce (A), à la partie inférieure du clavier. Introduisez et serrez tout d'abord les quatre vis ⑤ dans la partie (A) puis les quatre vis ④ dans le clavier. Le cas échéant, soulevez légèrement la partie (D). Veillez à ce que le câble ne soit pas coincé entre le clavier et le connecteur. Repoussez le câble dans la partie (D).

Conecte la pieza (D).

Conecte la pieza (D) al teclado como se muestra en la fig. 6. Inserte el conector de los pedales en el zócalo situado en la parte inferior del teclado. Alinee los orificios de los accesorios de conexión metálicos de la pieza (D) con los orificios de la parte media de la pieza (A) y los de la parte inferior del teclado. Primero inserte y atornille 4 tornillos ⑤ en la pieza (A), y luego inserte y atornille 4 tornillos ④ en el teclado. Mientras se fija la pieza (D) puede ser necesario levantarla un poco.

Al insertarlo, asegúrese de que el cable no quede retenido entre el teclado y el conector de los pedales. Empuje el cable para que entre completamente en la pieza (D).

Before Playing

Your Clavinova does not require professional installation or routine maintenance. However, it is **IMPORTANT** to be aware of the following.

INSTALLATION

1. Refer to your "Assembly Instructions" manual to ensure correct assembly. The Clavinova leg assemblies were not designed to accommodate additional weight.
 2. **WARNING:** Do not allow your Clavinova or its bench to rest on or be installed over power cords of any type. An electrical shock and/or fire hazard could possibly result from this type of improper installation.
 3. **WARNING:** Do not place objects on your Clavinova power cord or place it in a position where anyone could trip over, walk on or roll anything over it. An improper installation of this type creates a personal injury/fire hazard possibility.
 4. **Main Power Supply Verification:** Your Clavinova has been manufactured specifically for the main power supply voltages used in your area. If you should move, or if any doubt should exist, please consult your Yamaha Clavinova dealer for instructions.
The main power supply voltage is printed on the name plate. The name plate of the CVP-20 is on the bottom of the main body. In some areas a voltage selector may be provided on the rear panel of the main body. Make sure that the voltage selector is set for the voltage in your area.
 5. **Environment:** Your Clavinova should not be installed in a position that exposes the cabinet to direct sunlight or air currents having high humidity or heat levels. This type of installation can cause contact oxidation, case joint separation, and cabinet finish problems.
 6. **Vinyl Products:** Do not set vinyl items, (i.e., headphones, vinyl doilies, etc.) on the finished surfaces of your Clavinova or use a polyvinyl material to cover the unit for any extended period of time. A chemical reaction may occur between the finish chemicals and those contained in the polyvinyl products resulting in a permanent marring of the finish.
 7. **Electromagnetic interference (RFI):** Your Clavinova has been type tested and found to comply with all applicable regulations. However, if it is installed in the immediate proximity of other electronic devices, some form of interference may occur.
- **Name Plate Location**
The nameplate is located on the bottom panel.

MAINTENANCE

1. **SERVICE:** Your Clavinova contains no user serviceable components. Refer all service to qualified service technicians only.
2. **BENCH STRUCTURAL INTEGRITY (Bench optional):** If any motion or an "unsteady" sensation is noted in the bench, please check its structural integrity immediately. Discontinue use until any and all discrepancies are resolved. The bench was designed for seating only. No other applications are recommended.
3. **POWER:** When not in use, always turn your Clavinova "OFF".
4. **CLEANING/CARE**
 - A) **GENERAL:** DO NOT use chemically harsh (i.e., alcohol, paint thinner, etc.) or abrasive cleaners on any portion of your Clavinova.
 - B) **KEYS/CONTROL PANEL:** When cleaning the keys and control panels of your Clavinova, please use a soft absorbent-type cloth that has been dampened with a very mild solution of liquid soap and lukewarm water.
 - C) **CABINET:** Clean the cabinet portions of your Clavinova with a slightly dampened cloth containing a neutral cleaning agent. The cleaning agent selected should not contain a high wax content or any other substance that would have a tendency to form a "build-up" on the cabinet finish.

Voice Section

The CVP-20 offers 22 amazingly realistic AWM voices for enhanced musical variety and potential.

First, firmly insert the Clavinova's plug into a wall power outlet.

Step 1. Press the POWER button to turn the CVP-20 on.



Step 2. Adjust the MASTER VOLUME control.



This control determines the overall volume level of your Clavinova.

Step 3. Select any desired voice.

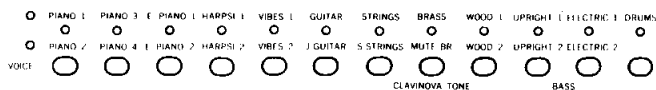

Each voice selector is used to select 2 different voices. When a voice selector is repeatedly pressed, the voice selected switches between the voice listed above the voice selector's LED and the voice listed below the LED. One of the two LEDs at the very left of the voice selector section also lights to indicate which of the 2 voices has been selected.

Piano 1 is automatically selected when the power is first turned on.

Step 4. Start playing.

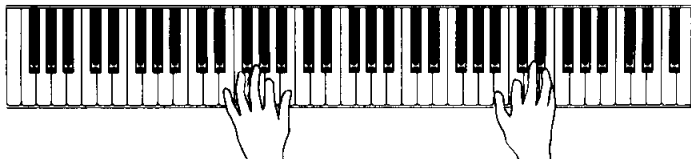

Experiment with other voices to discover the musical potential of the CVP-20.

[Lower Voice Selection]

The CVP-20's keyboard can be split into two in order to play different voices on the upper and lower keyboards.

Step 1. Press the LOWER ON button.



Step 2. Adjust the CHORD VOLUME control.

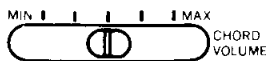

In the Piano ABC mode (refer to "Piano ABC"), the CHORD VOLUME control is used to adjust the chord volume.

Step 3. Select a voice while holding down the LOWER VOICE button. The voice selected in this step is played on the lower keyboard.

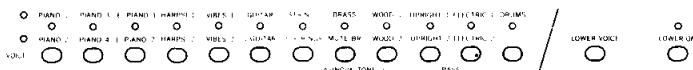

The lower keyboard is made up of the keys to the left of the assigned split position. (Refer to the SPLIT POSITION section in "Piano ABC".)

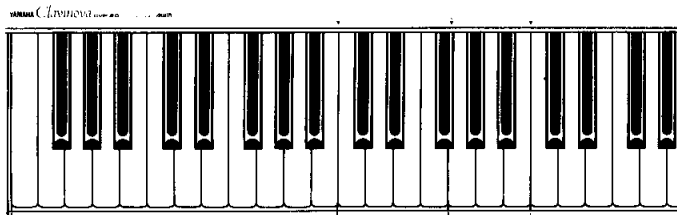

lower keyboard

[DAMPER PEDAL]

The DAMPER PEDAL allows you to hold the sound when the key is released, a feature similar to the damper pedal of an acoustic piano.

Note: The DAMPER PEDAL can also be used to activate an "extra sustain" mode for notes played without the DAMPER PEDAL's normal sustain effect. Hold down the MIDI/TRANPOSE button and press/release the DAMPER PEDAL, then release the MIDI/TRANPOSE button. Notes now have a slightly longer sustain. The "extra sustain" can be turned off by holding down the MIDI/TRANPOSE button and pressing/releasing the DAMPER PEDAL again.

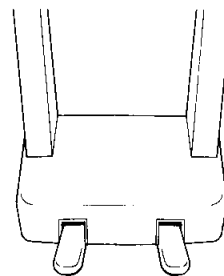

[LEFT PEDAL]

- SOFT
- SOSTENUTO
- START/STOP
- INTRO/ENDING
- FILL IN
- S STYLEPLAY
- LEFT PEDAL FUNCTION

The LEFT PEDAL can control the soft and sostenuto effects, Rhythm start/stop, Intro./Ending and Fill In, and the Solo Styleplay feature.

The function of the LEFT PEDAL is chosen with the LEFT PEDAL function selector. When the keyboard is turned on, SOFT is selected. The LED next to the selected function lights (SOFT has no LED).

• SOFT effect

The sounds played from the keyboard is softened when the LEFT PEDAL is pressed.

• SOSTENUTO effect

In the Sostenuto mode, if the LEFT PEDAL is pressed while notes or chords are played on the keyboard, the notes or chords played at this time are held as long as the LEFT PEDAL is held (as if the DAMPER PEDAL had been pressed). All subsequently played notes or chords are not sustained.

This makes it possible to sustain a chord, for example, while other notes are played "staccato".

• Rhythm START/STOP functions

The rhythm is started when the LEFT PEDAL is pressed while the rhythm is in the stop mode. The rhythm is stopped when the LEFT PEDAL is pressed while the rhythm is being sounded.

• Rhythm INTRO./ENDING functions

The rhythm starts after a 2-bar introduction pattern when the LEFT PEDAL is pressed while the rhythm is in the stop mode. The rhythm stops after a 2-bar ending pattern when the LEFT PEDAL is pressed while the rhythm is being sounded.

● **Rhythm FILL IN function**

A Fill In pattern accents your rhythm for one measure when the LEFT PEDAL is pressed while the rhythm is being sounded.

● **SOLO STYLEPLAY function**

The LEFT PEDAL's SOLO STYLEPLAY setting can not be selected unless the Solo Styleplay feature is turned on using the SOLO STYLEPLAY ON/OFF button.

If the Solo Styleplay feature is selected using the SOLO STYLEPLAY ON/OFF button and if the LEFT PEDAL function selector is set to SOLO STYLEPLAY, the Solo Styleplay feature is engaged when the LEFT PEDAL is held down. When the LEFT PEDAL is released, Solo Styleplay is turned off (the Piano ABC mode remains selected). (Refer to "Solo Styleplay" for further details.)

- The SOSTENUTO setting cannot be selected when Solo Styleplay is selected using the SOLO STYLEPLAY ON/OFF button. (However, the SOSTENUTO setting's LED will light.)

[Initial Touch Control]

The CVP-20's keyboard responds to the delicate changes of the touch you use while playing. This allows subtle variations in tone and timbre depending upon the strength of your touch. The amount of variation differs from voice to voice.

[Transposition]

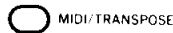

The MIDI/TRANPOSE button allows you to transpose the CVP-20's key within a range of +/- 600 cents or engage various MIDI functions. (Refer to "How to Use MIDI" for details on performing MIDI functions.)

The Transpose mode is normally selected when the TRANPOSE button is pressed. (MIDI functions are engaged when one of the voice selectors used to select MIDI functions are pressed while holding down the MIDI/TRANPOSE button.)

To raise the key: Hold down the MIDI/TRANPOSE button and press the TEMPO ► button. The key is raised by a half step (+100 cents) each time this is performed.

To lower the key: Hold down the MIDI/TRANPOSE button and press the TEMPO ◀ button. The key is lowered by a half step (-100 cents) each time this is performed.

To return to normal keyboard pitch: Hold down the MIDI/TRANPOSE button and simultaneously press the TEMPO ◀ and ► buttons. The key returns to the normal keyboard pitch.

- The changes in key are indicated on the TEMPO/BEAT indicator in the following manner:

Change	Display	Change	Display
- 600 cents	- 6	+ 100 cents	1
- 500 cents	- 5	+ 200 cents	2
- 400 cents	- 4	+ 300 cents	3
- 300 cents	- 3	+ 400 cents	4
- 200 cents	- 2	+ 500 cents	5
- 100 cents	- 1	+ 600 cents	6
+ / - 0 cents	0		

[Pitch Control]

The feature allows you to fine tune the pitch over the whole keyboard range.

To raise the pitch: Hold the E₀ and F₀ keys (the lowest two keys of the keyboard) down and repeatedly press any key between C₃ and B₃, inclusive. The pitch rises about 3 cents each time one of the keys is pressed.

To lower the pitch: Hold the E₀ and F[♯]₀ keys (the lowest white and the lowest black keys) down and repeatedly press any key between C₃ and B₃, inclusive. The pitch will lower about 3 cents each time one of the keys is pressed.

To return to normal pitch: Hold the E₀, F₀ and F[♯]₀ keys down to return to normal pitch (A₃ = 440Hz). When the power is turned on, the pitch is automatically set to A₃ = 440Hz.

- The pitch in Hertz is indicated on the TEMPO/BEAT indicator each time the pitch is changed.

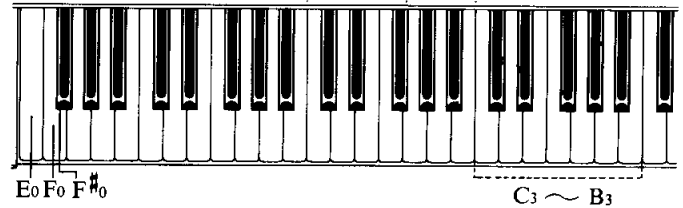

[Key Capabilities]

In the normal playing mode, a maximum of 16 notes can be sounded simultaneously. When using such features as rhythm, Piano ABC, Solo Styleplay, and Performance Memory, however, the total number of notes which can be sounded simultaneously is reduced.

Rhythm

Step 1. Select a rhythm pattern.

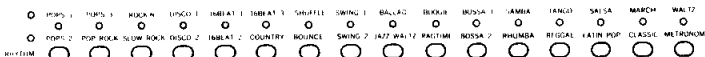

Each rhythm selector is used to select 2 different rhythms. When a rhythm selector is repeatedly pressed, the rhythm selected switches between the rhythm listed above the selector's LED and the rhythm listed below the selector's LED. One of the two LEDs at the very left of the rhythm selector section also lights to indicate which of the 2 rhythms has been selected.

POPS 1 is automatically selected when the power is first turned on.

Step 2. Adjust the RHYTHM VOLUME control.

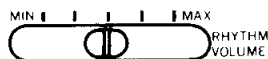

This controls the output level of the rhythm.

Step 3. Set the TEMPO.



The tempo can be adjusted within a range of $\text{♩} = 32$ to $\text{♩} = 280$. Pressing the TEMPO ◀ control slows down the tempo, and pressing the TEMPO ▶ control speeds up the tempo. Pressing both ◀ and ▶ controls at the same time restores the initial tempo ($\text{♩} = 120$).

Step 4. Start the rhythm.

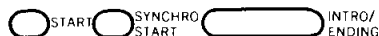

The rhythm starts as soon as the START button is pressed. When in the Synchro Start mode (when the SYNCHRO START button has been pressed), the rhythm starts after any key is pressed. (In the Piano ABC mode, a key on the lower keyboard must be pressed to start the rhythm.)

- The leftmost BEAT LAMP flashes when the Synchro Start mode is entered.

The CVP-20 is equipped with 32 dynamic rhythms patterns that accompany your melody performance automatically.

Step 5. Stop the rhythm.



The rhythm stops when the STOP button or the INTRO./ENDING button is pressed.

- The STOP button also cancels the Synchro Start mode and Fill In.

[FILL IN]



A Fill In pattern that suits the particular rhythm being played is added, for the rest of the current measure, to the rhythm as soon as the FILL IN button is pressed.

- If the FILL IN button is pressed at the end of the last beat of a measure, the Fill In pattern begins at the next measure.
- If the FILL IN button is pressed when the rhythm is not sounding, the rhythm will start off with a Fill In pattern. The second BEAT LAMP from the left lights to indicate that the rhythm is set to start off with a Fill In pattern.
- If the FILL IN button is pressed while in the Synchro Start mode, the rhythm starts off with a Fill In pattern once any key is pressed (when in the Piano ABC and Synchro Start modes, once a key of the lower keyboard is pressed.)
- The Fill In pattern will continue to sound if the FILL IN button is held down.

[INTRO./ENDING]



When the INTRO./ENDING button is pressed while the rhythm is stopped, the rhythm starts after a 2-bar introduction pattern. If it is pressed while the rhythm is sounding, the rhythm stops after an ending pattern.

Keyboard Percussion

[TEMPO / BEAT indicator]

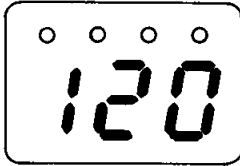

The TEMPO/ BEAT indicator displays the following information:

- The tempo is indicated in quantity of beats per minute (♩ =) when the tempo is being adjusted with the TEMPO controls.
- The current measure is indicated when a rhythm is sounding.
- Changes in key (Transposition) or pitch are indicated when the Transpose or Pitch control feature is used.
- The remaining Performance Memory storage capacity is indicated when one of the RECORD buttons is pressed (refer to "Performance Memory").
- The information for the various MIDI functions is indicated when using MIDI (refer to "How to Use MIDI").

[BEAT lamps]

- The BEAT lamps light up successively from left to right to indicate the beat of the measure and the tempo of the selected rhythm. The leftmost lamp indicates the first beat, or down beat, of a measure.
- When in the Synchro Start mode, the leftmost lamp flashes and indicates the exact tempo (in quarter notes) until the rhythm is started.
- The second BEAT lamp from the left lights when the rhythm is set to start off with a Fill In pattern.

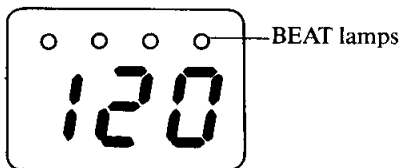

[Additional Information]

- There is no set Intro./Ending and Fill In pattern for Metronome. (There is a 2-bar blank if the INTRO./ENDING button is pressed to start the rhythm when Metronome is selected. No change in the rhythm pattern occurs when the FILL IN button is pressed or when the INTRO./ENDING button is pressed to stop the rhythm while Metronome is selected.)
- There is no set Piano ABC pattern for Metronome. (If Metronome is being used as the rhythm while in the Piano ABC mode, no sound can be heard from the lower keyboard.)

The CVP-20's Keyboard Percussion feature lets you play 22 different drums and latin percussion instruments from the keyboard.

STEP 1. Press the DRUMS button in the voice selector section.

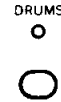

The DRUMS LED lights up.

STEP 2. Play any of the keys in the Keyboard Percussion section (F#4 ~ G6).

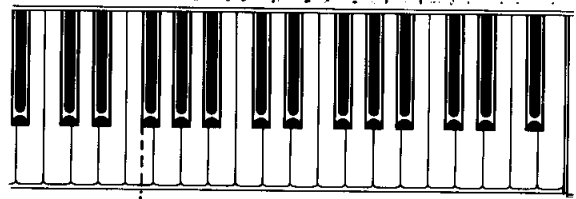

Keyboard Percussion

Each key is assigned to one percussion instrument. Refer to the following list and to the illustrations above the keys to identify the percussion instrument.

Key	Instrument	Key	Instrument
F#4	Rim Shot	G5	Electronic Tom High
G4	Bass Drum	G#5	Cabasa
G#4	Brush	A5	Conga Low
A4	Snare Drum Normal	A#5	Cowbell
A#4	Hi-hat Closed	B5	Conga High
B4	Electronic Snare Drum	C6	Timbale
C5	Tom Low	C#6	Tambourine
C#5	Hi-hat Open	D6	Metronome
D5	Tom Mid	D#6	Triangle Closed
D#5	Ride Cymbal	E6	Metronome
E5	Tom High	F6	Metronome
F5	Electronic Tom Mid	F#6	Triangle Open
F#5	Crash Cymbal	G6	Metronome

[Additional Information]

- When using the Keyboard Percussion feature, the keys to the left of C#4 will not sound unless the lower voice or the Piano ABC feature is used.
- If the Lower Voice or Piano ABC feature is being used, the keys of the lower keyboard will sound. The keys between C#4 and the highest note of the lower keyboard will not sound.

Piano ABC

Step 1. Press the Piano ABC button to select either the Single Finger or Fingered mode.

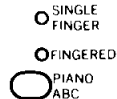

Step 2. Play a chord with the left hand.

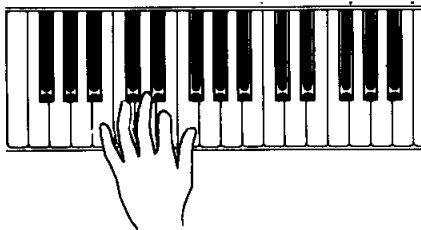

In the Single Finger mode:

Press a single key of the lower keyboard (refer to the SPLIT POSITION section of this chapter). The corresponding bass and full chord accompaniments will sound. When the rhythm is sounding, the accompaniments will continue to sound even after you take your fingers from the keyboard.

- To obtain minor chords, press the key corresponding to the desired chord along with the next black key.
- To obtain seventh chords, press the key corresponding to the desired chord along with the next white key.
- To obtain minor seventh chords, press the key corresponding to the desired chord along with the next black and white keys.

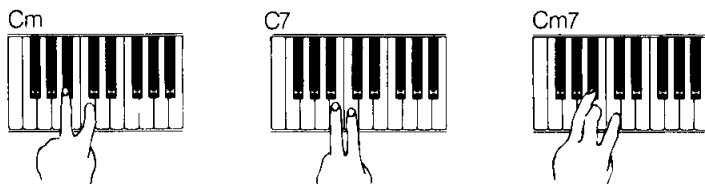

In the Fingered mode:

Play full chords on the lower keyboard to get automatic bass and chord accompaniments. When the rhythm is sounding, the accompaniments will continue to sound even after you take your fingers from the keyboard.

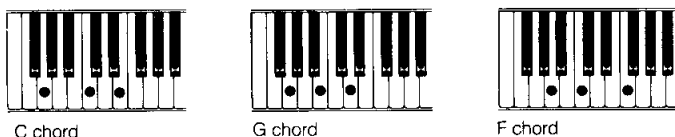

- The types of chords available in the Piano ABC Fingered Chord mode are as follows: major, minor, major seventh, sixth, minor seventh, minor seventh flatted fifth, seventh, seventh suspended fourth, augmented, diminished, minor sixth, and suspended fourth.

Step 3. Adjust the BASS VOLUME and CHORD VOLUME.

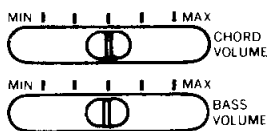

This feature provides, when the rhythm is running, automatic bass and chord accompaniments that match the rhythm you select.

[Changing Bass and Chord voices]

It is possible to change both bass and chord voices.

To change the bass voice:

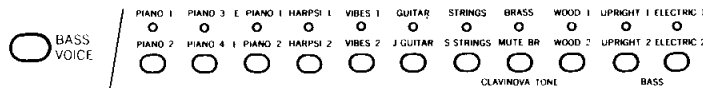

Press the voice selector corresponding to the desired voice while holding down the BASS VOICE button.

To change the chord voice:

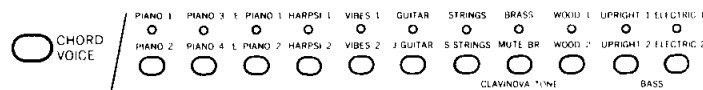

Press the voice selector corresponding to the desired voice while holding down the CHORD VOICE button.

To check the bass or chord voice:

Press the BASS VOICE or CHORD VOICE button. The corresponding voice selector's LED lights.

[SPLIT POSITION]

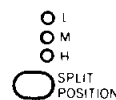

The split position (lower keyboard indicator) can be assigned to one of three position; low, middle, and high. Press the SPLIT POSITION selector to select one of the three split positions. The keys to the left of the selected position make up the lower keyboard. The three split positions are clearly marked by inverted triangles just above the corresponding keys. The middle split position is selected when the power is turned on.

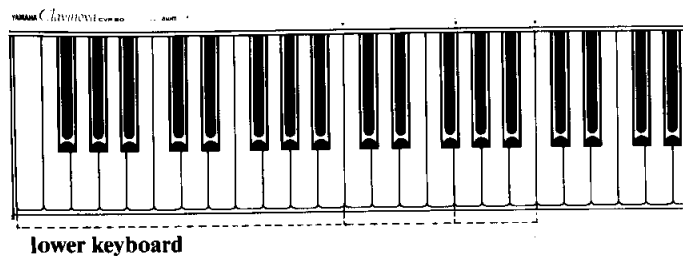

[Additional Information]

- In the PIANO ABC mode, the accompaniment pattern changes when a Fill In or Intro./Ending pattern is being used.
- The lower voice and Piano ABC feature can not be used at the same time.
- For some rhythm patterns, the Piano ABC accompaniment pattern may not vary when a different chord is selected. (For example, for some rhythm patterns, major and major seventh chords, and minor and minor seventh chords may have the same accompaniment pattern.)

Solo Styleplay

This feature selects the appropriate orchestra voices, rhythm and accompanying voices, and adds harmonizing instruments to match your melody performance. The accompaniments are selected according to the musical style you choose.

Step 1 Press the SOLO STYLEPLAY ON/OFF button to turn on the feature (the ON/OFF button's LED lights when the feature is on.)

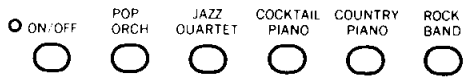

Step 2 Select one of the 5 different styles.



Step 3 Play a melody one note at a time, and play a chord on the lower keyboard.

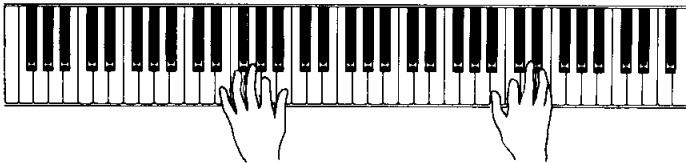

- Two to four harmonizing instruments accompany your melody performance.
- The chords can be played in either the Single Finger or Fingered mode. The rhythm and Piano ABC features are automatically started (i.e., the Synchro Start and Piano ABC modes are automatically selected in the Solo Styleplay mode). The Solo Styleplay feature selects the proper rhythm, and chord and bass voices to match the style selected.
- If the LEFT PEDAL function selector is set to Solo Styleplay, the Solo Styleplay mode is engaged only when the LEFT PEDAL is held down. Solo Styleplay is turned off (the Piano ABC mode is not not turned off) when the LEFT PEDAL is released.

Step 4 Changing rhythm, and orchestra, bass or chord voices.

It is possible to change the rhythm, and orchestra, bass or chord voice by following the procedure described in "Rhythm Section" and "Piano ABC".

- If the orchestra voice is changed, all harmonizing instruments are changed to the voice selected.

Step 5. Disengage the Solo Styleplay feature.

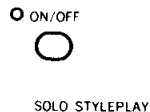

Press the SOLO STYLEPLAY ON/OFF button.

[Additional Information]

- The Piano ABC mode cannot be disengaged when in the Solo Styleplay mode.
- The LEFT PEDAL's Sostenuuto function cannot be selected when Solo Styleplay is used.
- The rhythm cannot be turned off in the Solo Styleplay mode. To stop the rhythm from sounding, turn the RHYTHM VOLUME control all the way down.
- Only one key of the the upper keyboard can be played at a time when Solo Styleplay is used.

Performance Memory

Your own performance can be recorded in the three-track Performance Memory. The three-tracks can be played back separately or all at once in "real time". To enjoy an ensemble performance, you can also play different voices as the recorded material is being played back.

Recording

Step 1. Press one of the RECORD buttons.



You can record on only one track at one time.

Step 2. Select any desired voice.

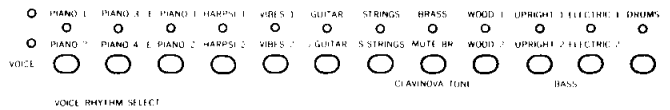

If desired, select a lower voice also.

Step 3. Select a rhythm, Piano ABC, and bass and chord voices, if desired.

The CVP-20 automatically enters the Synchro Start mode when a RECORD button is pressed. It is necessary to turn the RHYTHM VOLUME all the way down if you do not want the rhythm to be recorded.

Step 4. Adjust the Tempo.

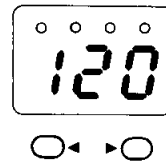

Step 5. Start Playing.

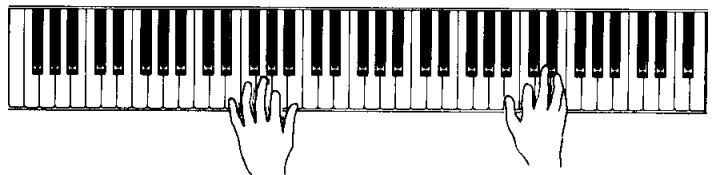

Recording will start as soon as any key is pressed or if the Rhythm START or INTRO./ENDING button is pressed. Your performance is recorded, along with any accompaniments, just as it is played.

- The following types of data are recorded: Key On/Off, Voice Number, Rhythm Number, Fill In, Intro./Ending, Rhythm Volume, Chord Volume, Bass Volume, Initial Tempo, Tempo Change, Piano ABC, Split Position, Bass and Chord Voice Numbers, Damper, Sostenuuto, and Soft.

Step 6. Stop recording.



Press the Rhythm STOP button to stop both the rhythm and the recording.

Playback

Step 1. Press the Performance Memory PLAY BACK button corresponding to the track you want played back.

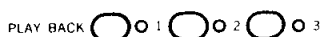

Step 2. Press the Rhythm START button.

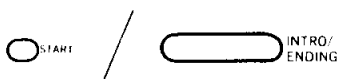

Playback can also be started by pressing the INTRO./ENDING button or by pressing a key of the lower keyboard while in the Synchro Start mode.

Step 3. Adjust the volume.



Adjust the MASTER, RHYTHM, and BASS and CHORD VOLUMES.

Step 4. Stop Playback.

Playback is stopped when any one of the following conditions are met.

1. All recorded data has been played back.
2. The Rhythm STOP, or INTRO./ENDING button is pressed.
3. A RECORD button is pressed during playback.

[Priority of Playback]

- During playback of multiple tracks recorded without Piano ABC and split position information, the rhythm information of the lowest numbered track takes priority. However, during playback of multiple tracks with one or more of the tracks having Piano ABC and split position information, the rhythm of the lowest numbered track with Piano ABC and split position information takes priority.
- Once playback is started, the playback priority of the tracks does not change.
- If one track is being played back while recording on another track is taking place, the last rhythm selected sounds and is recorded onto the recording track (either the rhythm of the playback track or the rhythm selected on the panel during recording). The recorded rhythm information of the track being played back is not affected even though a different rhythm is selected for recording on another track.

[Additional Information]

- When recording, voice changes may be desirable. These changes are played back as selected, but are not indicated on the control panel.
- When recording, changes in the rhythm pattern and tempo are memorized. However, during playback the rhythm and tempo can be manually changed.
- If Intro./Ending is used to start playback of material that was recorded with an introduction phrase (recording was started using the INTRO./ENDING button), playback begins with a 2-bar introduction phrase and not a 4-bar introduction phrase.
- If INTRO./ENDING is used to start playback of material that was recorded without an introduction phrase, playback starts after a 2-bar introduction phrase.
- A combined total of 12 notes can be played back simultaneously for the 3-tracks.
- During playback, voice changes made manually will not affect the sounds being reproduced.
- A total of approximately 5000 notes (31 Kbytes of storage capacity) can be stored in the Clavinova's memory.
- The remaining storage capacity is displayed in Kbytes on the TEMPO indicator when a RECORD button is pressed. (The number displayed will be between r28 and r00.)
- Performance Memory data stored in the CVP-20 can be kept for approximately one week even with the power off. To store the data longer turn on the power once every week.
- Recording and the rhythm stop when the memory is exceeded.
- The memory capacity of the Clavinova is reduced if the volume or tempo is changed or if the DAMPER PEDAL is used excessively during recording.
- Piano ABC and split position cannot be turned off from the panel during playback of a track recorded with Piano ABC or split position information.

Registration Memory

The CVP-20 can memorize your favorite control panel setting for easy recall later on.

Memorization

Step 1. Select your favorite panel setting.

The CVP-20 can memorize the settings for orchestra voice, lower voice, rhythm, Keyboard Percussion, Piano ABC, bass and chord voices, split position, left pedal functions, tempo, Solo Styleplay, rhythm volume, chord volume (including lower volume), and bass volume.

Step 2. Press the MEMORY button first. Then while holding down the MEMORY button press the RECALL button.



Recall

Step 3. Press the RECALL button.



The stored control panel setting is automatically selected.

[Additional Information]

- Only one control panel setting can be stored at one time.
- Once a new control panel setting is stored, the formerly memorized control panel setting is cleared from the memory.

Useful Information

Accessory Jacks

• HEADPHONES jack



This jack is used to connect stereo headphones (optional). When headphones are connected, no sound is produced from the Clavinova's speakers. This allows you the freedom to play the Clavinova any time without disturbing others.

• AUX. OUT L/R jacks

These jacks can be used to connect the CVP-20 to an amplifier or another speaker system. Also, by connecting the CVP-20 AUX. OUT L/R jacks to the LINE IN jacks of a tape deck, you can record music produced by the Clavinova.

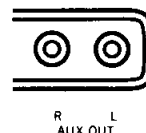

Note:

The AUX. OUT L/R jack signal must never be returned to the OPTIONAL IN jacks, either directly or through external equipment. Always use the OPTIONAL IN/OUT jacks when connecting Yamaha EM-series expander modules.

• OPTIONAL IN (L,R)/OUT (L,R)

These jacks are intended primarily for use with the Yamaha EM-series expander modules (EMR-1 Drum Box, EMT-1/10 Sound Box, EME-1 Reverb Box, and EMQ-1 Memory Box). In the case of the EME-1 Reverb Box, for example, the CVP-20's OPTIONAL OUT jacks connect to the EME-1 LINE IN jacks, and the EME-1 LINE OUT jacks connect back to the CVP-20's OPTIONAL IN jacks. This allows application of a range of high-quality effects, including reverb and echo, to the CVP-20's sound. Refer to the EM-series expander modules owner's manual for connection details.

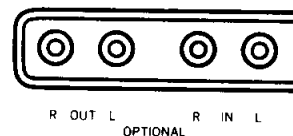

• MIDI IN/OUT/THRU

The MIDI (Musical Instrument Digital Interface) terminals conform to the world-wide standard for digital electronic instruments. These jacks enable you to connect your Clavinova to a computer or other MIDI compatible electronic instruments for musical data communication (refer to "How to Use MIDI").

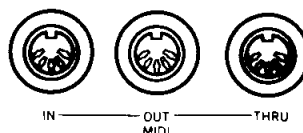

How to Use MIDI

Optional Accessories and Expander Modules

[Optional Accessories]

- **Key Cover (KC-761)**
- **Bench (BC-7)**
- **Stereo Headphones (HPE-5)**
Specially designed lightweight dynamic headphones with extra soft ear pads.
- **Connecting Cord (PSC-3)**
For connecting the CVP-20 to a stereo hi-fi system or other audio equipment.

[Expander-Modules]

The following expander modules have been especially designed for the Yamaha Clavinovas to expand their musical potential.

AWM Sound Expander	<i>Sound Box (EMT-10)</i>
FM Sound Expander	<i>Sound Box (EMT-1)</i>
Disk Recorder	<i>Memory Box (EMQ-1)</i>
Digital Drummer	<i>Drum Box (EMR-1)</i>
Digital Reverb	<i>Reverb Box (EME-1)</i>

Some optional items may not be available in some regions.

Important Advice

What to do if...

- 1. The unit does not operate when the power is turned on.**
Check to see if the AC plug is fully connected to a wall power outlet. Check to see if the outlet supplying power is live. If both these conditions are met and the Clavinova does not operate, unplug the cord and contact your Yamaha Clavinova dealer.
- 2. The Clavinova reproduces radio or TV signals.**
This can occur if there is a powerful transmitter such as a radio station located in your vicinity. Contact your Yamaha Clavinova dealer.
- 3. Occasional unpleasant static occurs.**
In the majority of such cases, the cause can be traced to the turning on or off of some household appliance.
- 4. The Clavinova interferes with radio or TV reception.**
The high frequency pulses used by the Clavinova may adversely affect TV or radio reception. Read the FCC information on page 67.
- 5. The sound of the Clavinova is distorted when it is connected to an auxiliary speaker system.**
When the Clavinova is connected to an auxiliary speaker system (home stereo, guitar, amplifier, etc.), distortion may occur when the keys are played forcefully while either the Clavinova's or auxiliary system's volume level is too high. Turn the volume down to a level where no distortion occurs. In addition to the distortion, damage to the speakers can occur if the volume levels are too high.

A brief introduction to MIDI

MIDI (Musical Instrument Digital Interface) is a world-wide standard interface system that allows MIDI compatible musical instruments and equipment to communicate through the transmission of digital signals. For most MIDI compatible instruments, information such as playing a key, changing voices and even note velocity can be transmitted or received. Once the information is transmitted, the receiving keyboard, called the slave instrument, responds precisely to produce a multi-instrument performance. In other words, a variety of instruments can be controlled or played from a single instrument. The controlling instrument is called the master instrument.

Example 1. The Clavinova can be connected to another MIDI compatible instrument such as a PortaTone.

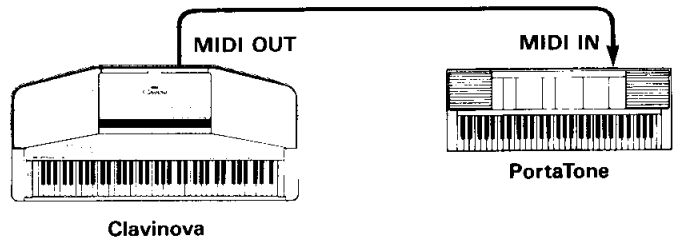

The MIDI OUT jack of the CVP-20 is connected to the MIDI IN jack of a PortaTone using a MIDI cable. This makes it possible to produce sound from the PortaTone, the slave instrument in this case, while playing just the Clavinova, the master instrument. It is also possible to utilize different voices on each instrument. For example, a piano voice can be played on the Clavinova while a strings voice is played on the PortaTone, allowing a solo performer to give an ensemble performance. The reverse connection where the MIDI OUT terminal of the PortaTone is connected to the MIDI IN terminal of the Clavinova is also possible.

Example 2. The Clavinova can be played from a musical computer.

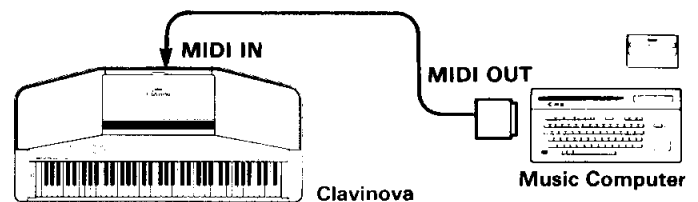

You can further expand your musical potential by playing the Clavinova from a musical computer. Whether you use a music software package or program your own software, the Clavinova can be played automatically. In this case, the voices can be freely selected on the control panel to match any style of music.

The above examples are only a small sample of what MIDI can do — the possibilities are endless.

Note: Always use a high-quality MIDI cable to connect MIDI terminals. Never use MIDI cables longer than 15 feet, since longer cables can pick up noise which can cause errors in transmitting and receiving data.

MIDI messages transmitted and received by the CVP-20

The following kinds of MIDI information (messages) can be transmitted and received by the CVP-20.

- **Note and Velocity Data**

This information tells the slave instrument to play a certain note (specified by the MIDI note number) at a certain dynamic control (specified by the MIDI velocity value). The data is transmitted or received by the Clavinova (depending upon the MIDI connection) just as it is played.

- **Program Change Numbers**

This information tells the slave instrument which voice to play. The Clavinova transmits, when it is the master instrument, a MIDI program change number between 0 and 23 corresponding to the voice selected. This causes the corresponding voice number of the slave instrument to be selected. The Clavinova can also receive program change data when it is the slave instrument. The transmission and reception of this information can be turned on or off, refer to page 18.

- **Control Change numbers**

This is the information for the SOFT/SOSTENUTO and DAMPER pedals. The information is transmitted when the Clavinova's pedals are pressed. If the receiving equipment is a tone generator or another keyboard, it will respond in the same way as the Clavinova's internal tone generator does when the pedals are pressed. The CVP-20 can also receive and respond to control change data. The transmission and reception of this information can be turned on or off, refer to page 18.

MIDI functions

The CVP-20 is equipped with 10 MIDI functions. These functions are selected by pressing the voice selectors listed in the table below while pressing the MIDI/TRANPOSE selector.

MIDI functions	Voice Selector
1. Send Channel Select	PIANO 1/2
2. Receive Channel Select	PIANO 3/4
3. Local On/Off	E. PIANO 1/2
4. Program Change On/Off	HARPSICHORD 1/2
5. Control Change On/Off	VIBES 1/2
6. Multi-timbre On/Off	GUITAR/JAZZ GUITAR
7. Split Send Mode	STRINGS/S.STRINGS
8. MIDI Clock Select	BRASS/MUTE BRASS
9. Panel Data Send	WOOD 1/2
10. Bulk Dump	UPRIGHT 1/2

- When the power is turned on, the send channel is set to 1, and the Clavinova is in the OMNI ON (all channel receive mode), Local On, Program Change On, Control Change On, Multi-timbre Off, Split Send Off, and Internal Clock modes.

Operating MIDI functions

1&2 Selecting MIDI Send and Receive Channels

MIDI allows data to be transmitted and received on 16 discrete channels over a single MIDI cable. This enables selective control of instruments and equipment that are connected in series.

Each instrument can be set to a different receive channel so that it only responds to data coded with the same channel number. For example, a single MIDI compatible sequence recorder can be connected to two different MIDI compatible instruments or tone generators. One of the instruments or tone generators can be set to receive data only on channel 1 while the other is set to receive data on channel 2. In this situation, the first instrument or tone generator will only respond to channel 1 data, while the second instrument or tone generator will respond only to channel 2 data. This allows the sequence recorder to "play" two completely different parts on the receiving instruments or tone generators.

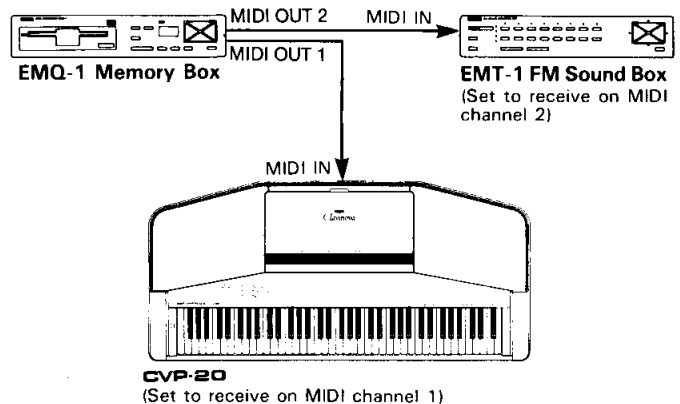

An OMNI On receive mode is also available. This allows an instrument to receive data on all 16 channels. (In the OMNI On mode, data from all channels are received but the receive channel is automatically set to 1.) In the OMNI On mode, it is not necessary to match the receive channel of the slave instrument with the send channel of the master instrument (except when receiving mode messages which must be received on channel 1.)

- **Setting the send channels**

Step 1. Press PIANO 1/2 while holding down the MIDI/TRANPOSE button.

Step 2. Press the TEMPO (◀, ▶) controls to select the channel. The selected channel is displayed on the TEMPO/BEAT indicator.

- **Setting the receive channels**

Step 1. Press PIANO 3/4 while holding down the MIDI/TRANPOSE button.

Step 2. Press the TEMPO (◀, ▶) controls to select the channel. The selected channel is displayed on the TEMPO/BEAT indicator.

When power is turned on, the CVP-20 is in the OMNI On mode and the TEMPO/BEAT indicator displays "ALL" when Step 1 above is performed. The OMNI On mode is released when a receive channel is selected, but it can be selected again by performing the above steps until the TEMPO/BEAT indicator reads "ALL".

3. Local On/Off

This is used to cancel the sounds of the CVP-20. Sound is only heard when the CVP-20 is played from an external device through MIDI. In the Local On mode, sound is heard from the Clavinova as notes are played (internal tone generator emits sound). In the Local Off mode, however, the Clavinova does not respond to the keys being played on its keyboard. It can still transmit information through the MIDI OUT jack when keys are played, and it can respond to MIDI data received through the MIDI IN jack. In the connection below, the tone generator responds to the keys being played on the Clavinova while the Clavinova responds to the MIDI data being sent from the EMQ-1 Memory Box.

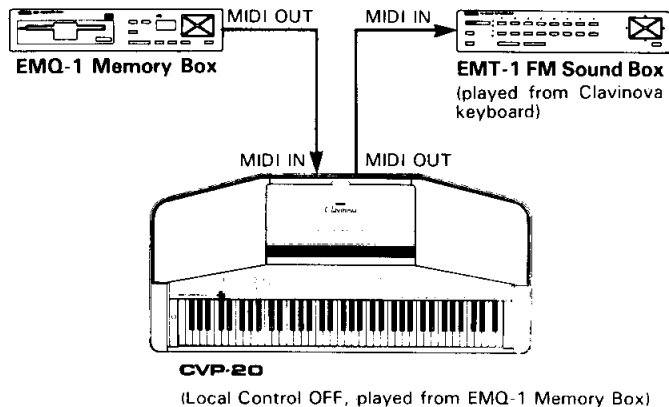

- Selecting the Local On or Off mode.
Step 1. Press E. PIANO 1/2 while holding down the MIDI/TRANSCOPE button. The E. PIANO 1/2 voice selector's LED is lit when in the Local Off mode. (If the LED is not lit, the Local On mode has been selected.)
Note: When the keyboard is split or when Piano ABC is used, only the upper keyboard can assume the Local Off mode.

4. Program Change On/Off

This is used to cancel the transmission and reception of voice select information (program changes). In the Program Change On mode, the Clavinova responds to any program change data (voice change data) from an external keyboard. It will also transmit program change data causing the corresponding voice number to be selected on the external device if the device is set to receive program change data. In the Program Change Off mode, program change data is not transmitted or received.

- Selecting Program Change On or Off mode
Step 1. Press HARPSICHORD 1/2 while holding down the MIDI/TRANSCOPE button. The HARPSICHORD 1/2 voice selector's LED is lit when in the Program Change Off mode. (If the LED is not lit, the Program Change On mode has been selected.)

5. Control Change On/Off

This is used to cancel the transmission and reception of DAMPER and SOFT/SOSTENUTO pedal data, and the reception of other control settings received from an external device. In the Control Change On mode, the Clavinova responds to any control change data from an external device and transmits control change data to external devices that are set up to receive Control Change data.

- Selecting the Control Change On or Off mode
Step 1. Press VIBES 1/2 while holding down the MIDI/TRANSCOPE button. The VIBES 1/2 voice selector's LED lights when in the Control Change Off mode. (if the LED is not lit, the Control Change On mode has been selected.)

6. Multi-timbre On/Off

In the Multi-timbre mode, the Clavinova's voices can be independently controlled on different MIDI channels from an external device such as the Yamaha EMQ-1 Memory Box. The CVP-20 responds to these signals and functions as a multi-timbral voice module. The possible reception channels, and initially set voices are listed below.

Reception Channel	Initial Voice
1	Piano 1
2	E. Piano 1
3	E. Bass 1
4	Vibes 1
5	Guitar
6	Strings
7	Brass
8	Wood 1
15	Rhythm ☆

☆ (Refer to the section "Channel 15" located below for further details.)

Program change, volume, sustain, soft and all note off data are also received on the channels listed above.

- Turning Multi-timbre mode on or off
Step 1. Press GUITAR/JAZZ GUITAR while holding down the MIDI/TRANSCOPE button. The GUITAR/JAZZ GUITAR voice selector's LED lights when the Multi-timbre mode is on. (If the LED is not lit, the Multi-timbre mode has been turned off.)
- Example: Connecting the EMQ-1 Memory Box to the CVP-20 to record 3 different parts.
Step 1. Connect the EMQ-1 to the CVP-20 as shown in the illustration below.

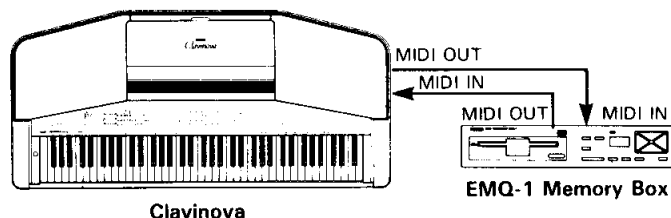

- Step 2. Select the first voice and MIDI send channel number. Record the first part on the EMQ-1.
Step 3. Activate the CVP-20's Multi-timbre mode, then select a new voice and MIDI send channel. Record the second part on the EMQ-1 using its over-dubbing feature.
Step 4. While still in the Multi-timbre mode, select a third voice and MIDI send channel. Record the third part on the EMQ-1 using its over-dubbing feature.
Step 5. Play back the EMQ-1 while still in the Multi-timbre mode. The recorded parts are played back using the individual voices selected during recording, providing a full ensemble sound.

- Channel 15
Channel 15 is used for the transmission/reception of rhythm data with set note numbers that conform to the note numbers of the Yamaha EMR-1 Drum Box expander module. The CVP-20's preset rhythm numbers are also transmitted through channel 15 as program change data. Channel 15 is set to program change number 99 when the Multi-timbre mode is first entered. No rhythm pattern sounds when this program change number is selected. A pattern will sound only after a different program change number is received by the CVP-20.

(Program change numbers 99 and 98 are both non-sounding program change numbers. They can be used for 4/4 time and 3/4 time rests, respectively.)

The note assignments for the percussion instrument feature of Channel 15 is shown in the following illustration. It is different from the note assignments illustrated on the CVP-20's panel.

Note: If the note assignments shown on the CVP-20's panel are desired for drum parts, use Channels 1 through 8.

NOTE ASSIGNMENTS

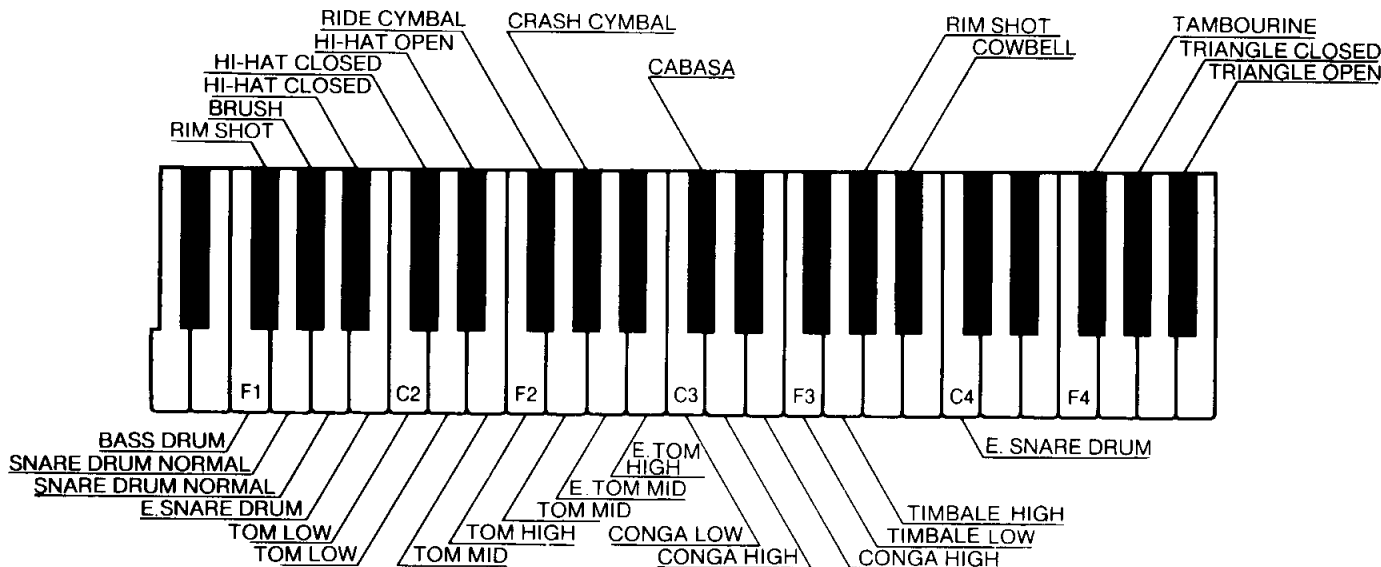

7. Split Send Mode

In this mode, the Clavinova's keyboard is split in two enabling each half of the keyboard to control a different slave instrument when keyboard split or Piano ABC mode is selected. The key on data for the keys to the left of the split point is sent on channel 2 (fixed). The key on data for keys to the right of the split point are sent over a designated send channel.

In the following connection, the Clavinova's lower keyboard controls EMT-1 Sound Box A, and the upper keyboard controls EMT-1 Sound Box B.

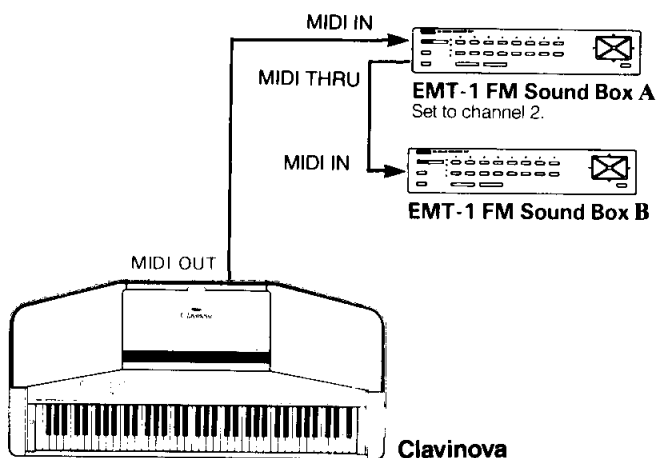

- **Selecting the Split Send On or Off mode**

Step 1. Press STRINGS/S. STRINGS while holding down the MIDI/TRANPOSE button. The STRINGS/S. STRINGS voice selector's LED lights when in the Split Send On mode. (if the LED is not lit, the Split Send Off mode has been selected.)

8. MIDI Clock Select

This mode is used to synchronize the tempo of the CVP-20's performance with the tempo of other instruments.

In the External Clock mode, an external equipment controls the timing of the CVP-20. In the Internal Clock mode, the CVP-20 controls its own timing.

- **Selecting the Internal or External Clock mode**

Step 1. Press BRASS/MUTE BRASS while holding down the MIDI/TRANPOSE button. The BRASS/MUTE BRASS voice selector's LED lights when in the External Clock mode. (If the LED is not lit, the Internal Clock mode has been selected.)

9. Panel Data Send

This function is used to send the panel settings of the CVP-20 to another MIDI compatible device. This is particularly useful when sending data to a MIDI sequence recorder that will control the CVP-20 during playback of recorded material.

By transmitting the CVP-20 control panel settings and recording them on a MIDI sequence recorder prior to the actual performance data, the control panel is automatically restored to the same settings when the performance is played back.

- **Selecting the Panel Data Send mode**

Step 1. Press WOOD 1/2 while holding down the MIDI/TRANPOSE button. The WOOD 1/2 voice selector's LED lights while the data is being sent.

10. Bulk Data Dump

This is used to send the data stored in the Performance and Registration Memories to such MIDI compatible devices as the Yamaha EMQ-1 Memory Box, other sequence recorders, and computers.

- **Selecting Bulk Data Dump**

Step 1. Press UPRIGHT 1/2 while holding down the MIDI/TRANPOSE button. The UPRIGHT 1/2 voice selector's LED lights while the data is being sent.

[Important Notice]

MIDI instruments and equipment have slightly different MIDI specifications. Refer to the instrument or equipment's MIDI implementation charts to determine what is and what is not possible. The CVP-20's MIDI implementation chart is on the final page of this manual.

MIDI DATA FORMAT

If you're already very familiar with MIDI, or are using a computer to control your music hardware with computer-generated MIDI messages, the data provided in this section can help you to control the Clavinova.

1. NOTE ON/OFF

DATA FORMAT: [9xH] → [kkH] → [vvH]

9xH = Note ON/OFF event; x = channel number: 0H — FH
kkH = Note number

Transmitted: (1CH — 67H = E₀ — G₇)

Recognized: (15H — 6CH = A₋₁ — C₇)

vvH = Velocity (Note ON = 01H — 7FH, Note OFF = 00H)

Note: Default channel is Channel 1.

2. CONTROL CHANGES AND MODE MESSAGES

DATA FORMAT: [BxH] → [ccH] → [ddH]

BxH = Control event; x = channel number: 0H — FH

ddH = Control value

Control Changes:

cc	Parameter	dd
07H	Volume ¹	00H — 7FH
40H	Damper pedal	00H — 3FH = OFF; 40H — 7FH = ON.
42H	Soft pedal	00H — 3FH = OFF; 40H — 7FH = ON.
43H	Sostenuto pedal ²	00H — 3FH = OFF; 40H — 7FH = ON.

Notes: ¹ Recognized if MULTI TIMBRE mode is ON.

² Recognized if MULTI TIMBRE mode is OFF.

Mode Messages (Receive only):

cc	Parameter	dd
7AH	Local ON/OFF	00H = OFF; 7FH = ON;
7BH	All notes OFF	00H
7CH	OMNI OFF/All notes OFF	00H
7DH	OMNI ON/All notes OFF	00H

Note: Default transmitted mode is OMNI OFF/POLY; default recognized mode is OMNI ON/POLY.

3. PROGRAM CHANGES

DATA FORMAT: [CxH] → [ddH]

CxH = Program event; x = channel number: 0H — FH

ddH = Program number

dd	Voice
00H	PIANO 1
01H	PIANO 3
02H	E. PIANO 1
.	.
.	.
17H	DRUMS

4. SYSTEM REAL-TIME MESSAGES (Single-Byte Messages)

F8H: Timing Clock

FAH: Start

FCH: Stop

FEH: Active Sensing:

If not received within 400 milliseconds, a Note OFF occurs.

5. SYSTEM EXCLUSIVE MESSAGES

a) MULTI TIMBRE MODE

DATA FORMAT: [F0H] → [43H] → [73H] → [ID CODE] → [nnH] → [F7H]

F0H = System Exclusive Message

43H = Yamaha ID

73H = Single Keyboard ID

ID CODE = 01H, 1BH, or 1CH

nnH = 15H: MULTI TIMBRE mode ON;

13H: MULTI TIMBRE mode OFF.

F7H = End of message.

b) RHYTHM, REVERB, AND PERFORMANCE MEMORY CONTROLS

Rhythm Number Change:

DATA FORMAT: [F0H] → [43H] → [73H] → [1CH] → [40H] → [nnH] → [F7H]

F0H = System Exclusive Message

43H = Yamaha ID

73H = Single Keyboard ID

1CH = CVP 20 Model ID code

40H = Rhythm number change command

nnH = 00H — FFH: Panel Rhythm

62H: 3/4 time

63H: 4/4 time

F7H = End of message.

Tempo, Fill In, Intro./Ending, Reverb:

DATA FORMAT: [F0H] → [43H] → [73H] → [1CH] → [4nH] → [F7H]

F0H = System Exclusive Message

43H = Yamaha ID

73H = Single Keyboard ID

1CH = CVP 20 Model ID code

4nH = 41H: Fill In ON

42H: Intro./Ending ON

43H: Tempo Up ON

44H: Tempo Down ON

45H: Tempo Center ON

46H: Reverb ON

47H: Reverb OFF

F7H = End of message.

Performance Memory:

DATA FORMAT: [F0H] → [43H] → [73H] → [1CH] → [nxH] → [F7H]

F0H = System Exclusive Message

43H = Yamaha ID

73H = Single Keyboard ID

1CH = CVP 20 Model ID code

nxH = 5xH: Performance Memory OFF;

6xH: Performance Memory ON.

x: track number

F7H = End of message.

c) PANEL DATA SEND (Transmit Panel Data)

DATA FORMAT:

[F0H] → [43H] → [0xH] → [7CH] → [BYTE COUNT: [hhH] [llH]] → [ASCII ID MSG] → [VERSION #] → [PANEL DATA] → [CHECKSUM] → [F7H]

F0H = System Exclusive Message

43H = Yamaha ID

0xH = Channel; x: channel number: 0H — FH

7CH = Format code

BYTE COUNT = (# of Panel Data bytes × 2) + 12 (the ASCII ID MSG length)

hhH: High byte;

llH: Low byte.

ASCII ID MSG=

53H 4BH 20H 20H 43H 56H 50H 30H 32H 30H
'S' 'K' blank blank 'C' 'V' 'P' '0' '2' '0'

VERSION # = 2 bytes (binary)

PANEL DATA = 32 bytes (16 ASCII-coded Panel Data bytes)

CHECKSUM = 1 byte

F7H = End of message.

d) PANEL DATA REQUEST (Request Panel Data)

DATA FORMAT: [F0H] → [43H] → [2xH] → [7CH] → [F7H]

F0H = System Exclusive Message

43H = Yamaha ID

2xH = Panel Data Request command

x: channel number

7CH = Format code

F7H = End of message.

e) BULK DATA SAVE (Send Registration and Performance Memory Contents)

DATA FORMAT:

Bulk Data Save Message Header:

[F0H] → [43H] → [73H] → [06H] →

Registration Memory record:

[Hdr1] → [BYTE COUNT: [hhH] [hlH] [lhH] [llH]] → [Hdr2] →

[Reg. Mem. Data] → [CHECKSUM] →

Performance Memory Sector record:

[Hdr1] → [BYTE COUNT: [hhH] [hlH] [lhH] [llH]] → [Hdr2] →

[Perf. Mem. Data] → [CHECKSUM] →

Performance Memory Index record (after last Sector record):

[Hdr1] → [BYTE COUNT: [hhH] [hlH] [lhH] [llH]] → [Hdr2]

→ [Perf. Mem. Data] → [CHECKSUM]

Bulk Data Save Message Header:

F0H = System Exclusive Message

43H = Yamaha ID

73H = Single Keyboard ID

06H = Bulk Data Save Request command

Registration Memory record:

Hdr1 = ASCII 'A' (41H)

BYTE COUNT:

[hhH] [hlH] [lhH] [llH] =

of bytes in current Registration Memory sector:

(# of bytes × 2) + 1

(ASCII coded 16-bit number)

Hdr2 = 1FH

Reg. Mem. Data = 32 bytes of ASCII-coded Registration Memory Data

CHECKSUM = 1 byte

Performance Memory Sector record:

Hdr1 = ASCII 'A' (41H)

BYTE COUNT:

[hhH] [hlH] [lhH] [llH] =

of bytes in current Performance Memory sector:

(# of bytes × 2) + 1

(ASCII coded 16-bit number)

Hdr2 = ranges from 00H to # of Perf. Mem. sectors

Perf. Mem. Data = 2048 bytes of ASCII-coded Performance Memory Data

CHECKSUM = 1 byte

Performance Memory Index record (after last Sector record):

Hdr1 = ASCII 'A' (41H)

BYTE COUNT:

[hhH] [hlH] [lhH] [llH] =

Index Record Data (31 bytes × 2) + others (32 bytes)

+ 1

(ASCII coded 16-bit number)

Hdr2 = 1FH

Index Data = 62 bytes of ASCII-coded Index Data + 32

CHECKSUM = 1 byte

7FH = End of message.

f) BULK DATA LOAD (Receive Registration and Performance Memory Contents)

DATA FORMAT: [F0H] → [43H] → [73H] → [ID CODE] → [07H] → [F7H]

F0H = System Exclusive Message

43H = Yamaha ID

73H = Single Keyboard ID

ID CODE = 01H, 1BH or 1CH

07H = Bulk Data Load command

F7H = End of message.

- The above mentioned data are all the user system exclusive data that are available on the CVP-20.

Specifications

Technische Daten

Spécifications

Especificaciones

* Specifications subject to change without notice.
 * Änderungen ohne Vorankündigung vorbehalten.
 * Sous réserve de modification des caractéristiques sans préavis.
 * Especificaciones sujetas a cambio sin previo aviso.

Keyboard:	76 Keys (E ₀ ~ G ₆)
Tone Generator:	AWM
Voice Selectors:	22 Voices: Piano 1·2·3·4, E. Piano 1·2, Harpsichord 1·2, Vibes 1·2, Guitar, Jazz Guitar, Strings, S. Strings, Brass, Mute Brass, Wood 1·2, Upright Bass 1·2, Electric Bass 1·2; Drums (22 Keyboard Percussion Sounds); Lower On, Lower Voice Selector
Piano ABC:	Single Finger, Fingered, Chord Voice, Bass Voice, Chord Volume, Bass Volume, Split Position
Auto Rhythm Section:	32 Rhythms: Pops 1·2·3, Pop Rock, Rock 'n' Roll, Slow Rock, Disco 1·2, 16 Beat 1·2·3, Country, Shuffle, Bounce, Swing 1·2, Ballad, Jazz Waltz, Boogie, Ragtime, Bossa 1·2, Samba, Rhumba, Tango, Reggae, Salsa, Latin Pop, March, Classic, Waltz, Metronome; Fill In, Intro./Ending, Rhythm Volume, Start, Synchro Start, Stop, Tempo Controls (◀, ▶), LED Tempo Indicator
Keyboard Percussion:	22 AWM Percussion Sounds: Rim Shot, Bass Drum, Brush, Snare Drum, Hi-hat Closed, Electronic Snare Drum, Tom Low, Hi-hat Open, Tom Mid, Ride Cymbal, Tom High, Electronic Tom Mid, Crash Cymbal, Electronic Tom High, Cabasa, Conga Low, Cowbell, Conga High, Timbale, Tambourine, Triangle Closed, Triangle Open
Solo Styleplay:	5 Styles: Pop Orchestra, Jazz Quartet, Cocktail Piano, Country Piano, Rock Band; On/Off
Performance Memory Section:	3 Tracks: Record, Playback
Registration Memory Section:	Memory, Recall
Pedal Controls:	Damper, Soft/Sostenuto (Solo Styleplay, Rhythm Start/Stop, Fill In, Intro./Ending)
Other controls:	Master Volume, MIDI/Transpose, Pitch, Power Switch
Connections:	MIDI IN/OUT/THRU, OPT IN/OUT (L/R), AUX OUT (L/R), Headphones
Power Amplifier:	40W (20W × 2)
Speakers:	13cm(5") × 2 5cm(2") × 2
Dimensions:	125.1cm(W) × 56.2cm(D) × 79.5cm(H) (49-1/4" × 22" × 31-1/3")
Weight:	45.8kg (100-4/5lbs)

MIDI Implementation Chart

Version: 1.0

Function		Transmitted	Recognized	Remarks
Basic Channel	Default Changed	1 1~16	1 1~16	
Mode	Default Messages	3 × *****	1 OMNI On, OMNI Off ×	
Note Number	True voice	28~103 *****	21~108 21~108	
Velocity	Note on Note off	○ 9nH, v=1~127 × 9nH, v=0	○ v=1~127 ×	
After Touch	Key's Ch's	× ×	× ×	
Pitch Bender		×	×	
Control Change	07 64 66 67	× ○ ○ ○	○ *1 ○ ○ *2 ○	Volume Damper Sostenuto Soft Pedal
Program Change	True #	○ 0~23 *****	○ 0~23 0~23	
System Exclusive		○	○	
System Common	Song Pos Song Sel Tune	× × ×	× × ×	
System Real Time	Clock Commands	○ ○	○ ○	
Aux Messages	Local ON/OFF All Notes OFF Active Sense Reset	× × ○ ×	○ ○ (123~125) ○ ×	
Notes: *1 = receive if Multi-timbre mode is on *2 = receive if Multi-timbre mode is off				

Mode 1 : OMNI On, POLY Mode 2 : OMNI On, MONO
 Mode 3 : OMNI Off, POLY Mode 4 : OMNI Off, MONO

○ : Yes
 × : No

FCC INFORMATION (U.S.A.)

1. IMPORTANT NOTICE: DO NOT MODIFY THIS UNIT!

This product, when installed as indicated in the instructions contained in this manual, meets FCC requirements. Modifications not expressly approved by Yamaha may void your authority, granted by the FCC, to use the product.

2. IMPORTANT:

When connecting this product to accessories and/or another product use only high quality shielded cables. Cable/s supplied with this product MUST be used. Follow all installation instructions. Failure to follow instructions could void your FCC authorization to use this product in the USA.

3. NOTE:

This product has been tested and found to comply with the requirements listed in FCC Regulations, Part 15 for Class "B" digital devices. Compliance with these requirements provides a reasonable level of assurance that your use of this product in a residential environment will not result in harmful interference with other electronic devices. This equipment generates/uses radio frequencies and, if not installed and used according to the instructions found in the users manual, may cause interference harmful to the operation of other electronic devices. Compliance with FCC regulations does not guarantee that interference will not occur in all installations. If this product is found to be the source of interference, which can be determined by turning the unit "OFF" and "ON", please try to eliminate the problem by using one of the following measures:

Relocate either this product or the device that is being affected by the interference.

Utilize power outlets that are on different branch (circuit breaker or fuse) circuits or install AC line filter/s.

In the case of radio or TV interference, relocate/reorient the antenna. If the antenna lead-in is 300 ohm ribbon lead, change the lead-in to co-axial type cable.

If these corrective measures do not produce satisfactory results, please contact the local retailer authorized to distribute this type of product. If you can not locate the appropriate retailer, please contact Yamaha Corporation of America, Electronic Service Division, 6600 Orangethorpe Ave, Buena Park, CA90620

The above statements apply ONLY to those products distributed by Yamaha Corporation of America or its subsidiaries.

* This applies only to products distributed by YAMAHA CORPORATION OF AMERICA.

Wichtiger Hinweis für die Benutzung in der Bundesrepublik Deutschland.

Bescheinigung des Importeurs

Hiermit wird bescheinigt, daß der/die/das

Electronic Piano CVP-20

(Gerät, Typ, Bezeichnung)

in Übereinstimmung mit den Bestimmungen der VERFÜGUNG 1046/84

(Amtsblattverfügung)

funk-entstört ist.

Der Deutschen Bundespost wurde das Inverkehrbringen dieses Gerätes angezeigt und die Berechtigung zur Überprüfung der Serie auf Einhaltung der Bestimmungen eingeräumt.

Yamaha Europe GmbH

Name des Importeurs

• Dies bezieht sich nur auf die von der Yamaha Europa GmbH vertriebenen Produkte.

CANADA

THIS DIGITAL APPARATUS DOES NOT EXCEED THE "CLASS B" LIMITS FOR RADIO NOISE EMISSIONS FROM DIGITAL APPARATUS SET OUT IN THE RADIO INTERFERENCE REGULATION OF THE CANADIAN DEPARTMENT OF COMMUNICATIONS.

LE PRESENT APPAREIL NUMERIQUE N'EMET PAS DE BRUITS RADIO-ELECTRIQUES DEPASSANT LES LIMITES APPLICABLES AUX APPAREILS NUMERIQUES DE LA "CLASSE B" PRESCRITES DANS LE REGLEMENT SUR LE BROUILLAGE RADIOELECTRIQUE EDICTE PAR LE MINISTERE DES COMMUNICATIONS DU CANADA.

• This applies only to products distributed by Yamaha Canada Music Ltd.
• Ceci ne s'applique qu'aux produits distribués par Yamaha Canada Musique Ltée.

IMPORTANT NOTICE FOR THE UNITED KINGDOM

Connecting the Plug and Cord

IMPORTANT. the wires in this mains lead are coloured in accordance with the following code:

BLUE : NEUTRAL

BROWN : LIVE

As the colours of the wires in the mains lead of this apparatus may not correspond with the coloured markings identifying the terminals in your plug proceed as follows:

The wire which is coloured BLUE must be connected to the terminal which is marked with the letter N or coloured BLACK.

The wire which is coloured BROWN must be connected to the terminal which is marked with the letter L or coloured RED.

Making sure that neither core is connected to the earth terminal of the three pin plug.

• This applies only to products distributed by Yamaha-Kemble Music (U.K.) Ltd.

YAMAHA