

# MONOPOSTO™ ASSEMBLY

## STEP 1

ASSEMBLE THE SHOULDERS TO YOUR CARRIER BY SLIDING THE UPPER TUBES (A) INTO THE SHOULDER CLAMPS (B) KEEPING THEM LOOSE. ATTACH THE BACK BAR (C) TO THE SHOULDERS WITH THE BACK BAR NUTS (F) USING A 7/16 [ 11MM ] WRENCH.

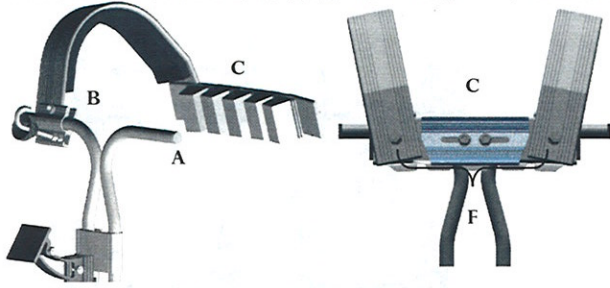

## STEP 2

HANG THE CARRIER FROM A TABLE **MAKING SURE ALL FOUR POINTS OF THE SHOULDERS AND BACK BAR ARE TOUCHING THE SURFACE OF THE TABLE. ALIGN THE CARRIER VERTICALLY AND PARALLEL TO THE TABLE LEG. MAKE SURE ALL FOUR POINTS OF THE SHOULDERS AND BACK BAR ARE STILL TOUCHING THE SURFACE OF THE TABLE** THEN TIGHTEN THE SHOULDER CLAMPS (B) WITH A DRUM KEY UNTIL THE CARRIER IS RIGID.

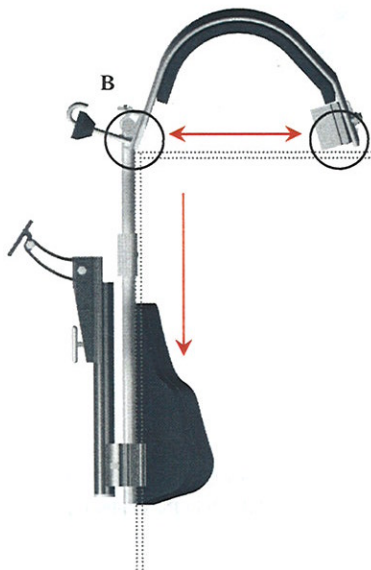

MAY TUBULAR VESTS, CONTOUR HINGE AND MONOPOSTO CARRIERS ARE COVERED UNDER THE VARIOUS US PATENTS INCLUDING BUT NOT RESTRICTED TO 6,323,407 6,329,583 BI 5,691,492 6,028,257 6,172,290 BI 6,881,886 B2 & 6,403,869 B2 PLUS OTHER US. AND FOREIGN PATENTS PENDING.

# M

RANDALL MAY INTERNATIONAL™

# MONOPOSTO™

*Instructions for Assembly & Custom Fit*

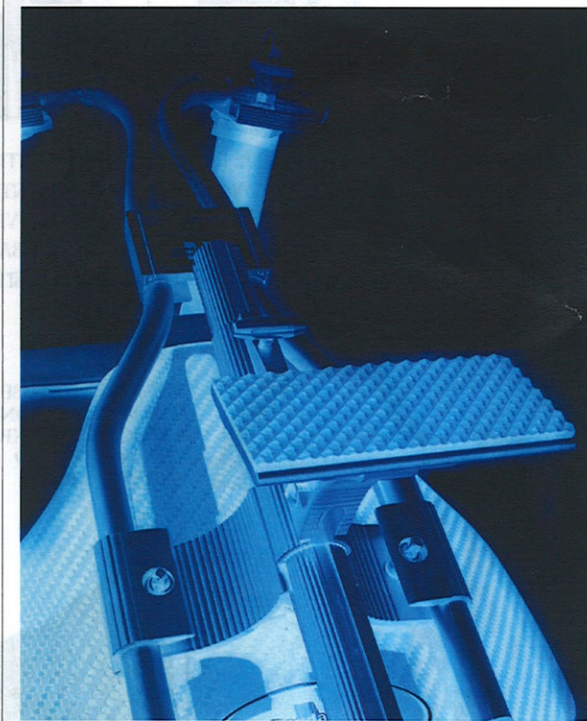

MAY TUBULAR TECHNOLOGY



### STEP 3

ATTACH THE BASS DRUM TO YOUR CARRIER BY HOOKING THE CARRIER'S J BOLTS (D) ONTO THE DRUM'S EYEBOLTS.

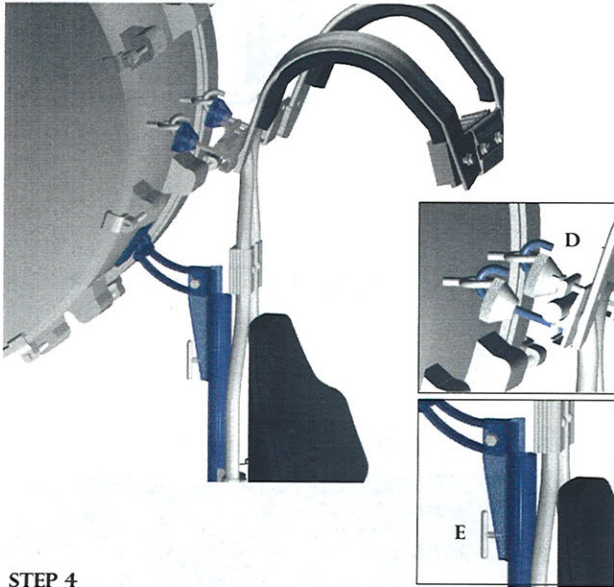

### STEP 4

TO ADJUST THE HEIGHT OF THE BASS DRUM, LOOSEN THE T-BOLT (E) AND MOVE THE MONOPOSTO SLIDER™ UNTIL YOU REACH THE DESIRED HEIGHT. YOU CAN ALSO INVERT THE MONOPOSTO SLIDER™ (SEE BELOW) FOR LARGER BASS DRUMS. TIGHTEN THE T-BOLT (E) TO LOCK YOUR POSITION IN PLACE.

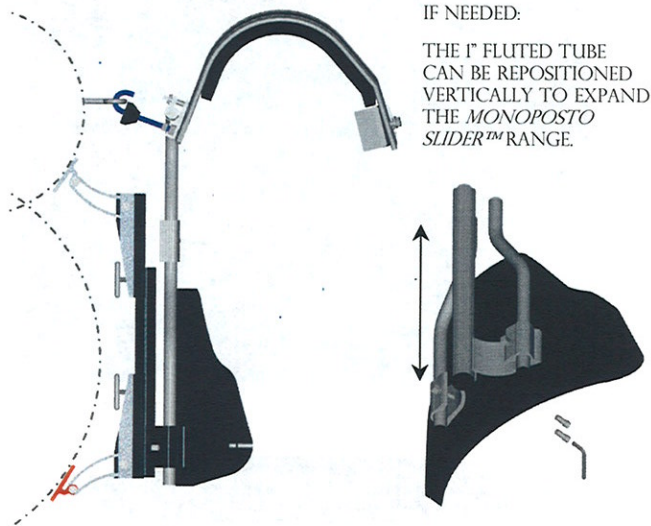

### STEP 5

AFTER YOU HAVE POSITIONED YOUR DRUM TO YOUR PREFERRED PLAYING HEIGHT, ROTATE BOTH THUMB M-LOKS™ (F) FORWARD UNTIL THEY ARE TOUCHING THE BASS DRUM EYE BOLTS. THE BASS DRUM IS NOW SECURED TO THE CARRIER AND FREE FROM ANY ACCESS MOVEMENT.

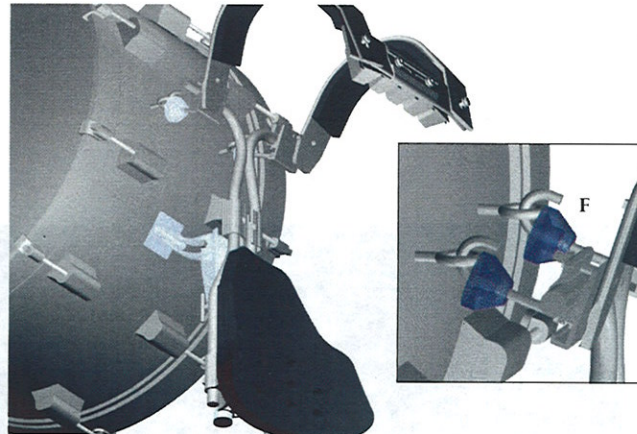

AT THIS POINT, YOUR MONOPOSTO™ CARRIER IS NOW PROPERLY ASSEMBLED AND READY FOR THE FIELD. IF YOU WANT TO FURTHER CUSTOMIZE YOUR CARRIER, PLEASE CONTINUE WITH THE INSTRUCTIONS CUSTOM FIT SIZING.

## CUSTOM FIT SIZING

### STEP 1-OPTIONAL

FOR EXTENDING THE ABDOMEN PLATE LOWER ON YOUR BODY WITHOUT INTERFERING WITH YOUR LEGS, INVERT THE ABDOMEN PLATE UPSIDE DOWN AS SHOWN.

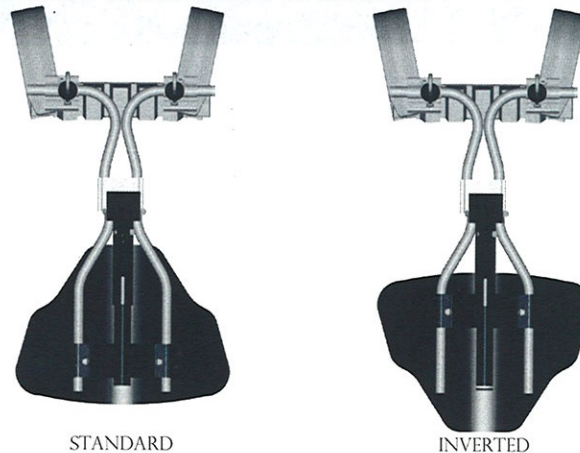

### STEP 2

IF YOU FEEL THE SHOULDERS NEED TO BE WIDENED, REMOVE THE COMFORT CORE™ CUSHION FROM THE BACK BAR, THEN, WITH YOUR CARRIER STILL ON, LOOSEN THE SHOULDER CLAMPS (B) BY ROTATING EACH BOLT WITH A DRUM KEY 1-2 TURNS. NEXT, HAVE SOMEONE LOOSEN THE BACK BAR NUTS (E) WITH A 7/16 (11MM) WRENCH AND THE BACK BAR COUPLER (F) WITH THE PROVIDED HEX KEY. SPREAD THE SHOULDERS AND BACK BAR TO YOUR DESIRED FIT. ONCE THIS FIT IS ACHIEVED, HAVE SOMEONE TIGHTEN ALL FOUR BACK BAR POINTS (E & F) BUT LEAVE THE SHOULDER CLAMPS (B) LOOSE.

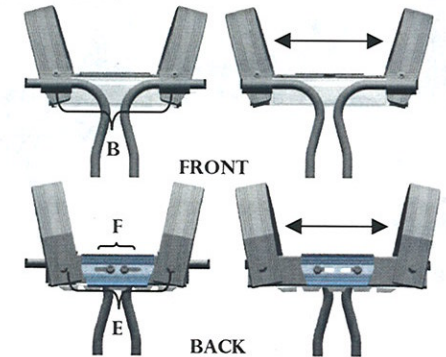

### STEP 3

TAKE OFF THE CARRIER AND PLACE IT BACK ON THE TABLE MAKING SURE ALL FOUR POINTS OF THE SHOULDERS AND BACK BAR ARE TOUCHING THE SURFACE OF THE TABLE AND RETIGHTEN THE SHOULDER CLAMPS (B).

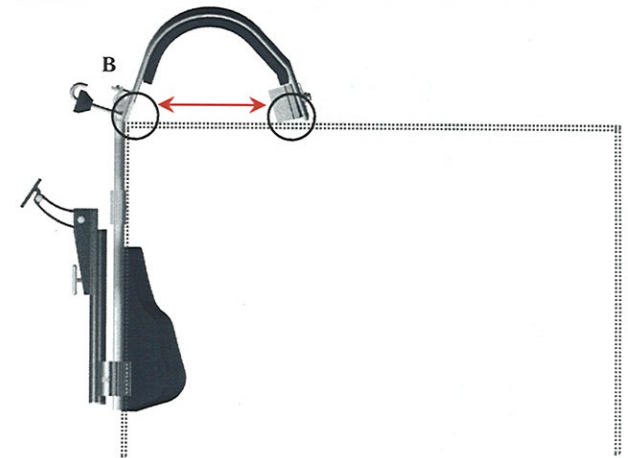

### STEP 4

ATTACH YOUR DRUM FOR A FINAL COMFORT TEST. MAKE ANY NECESSARY ADJUSTMENTS IF NEEDED IN STEPS 1-3.