

YMTASSY

# ASSEMBLY AND PARTS LIST

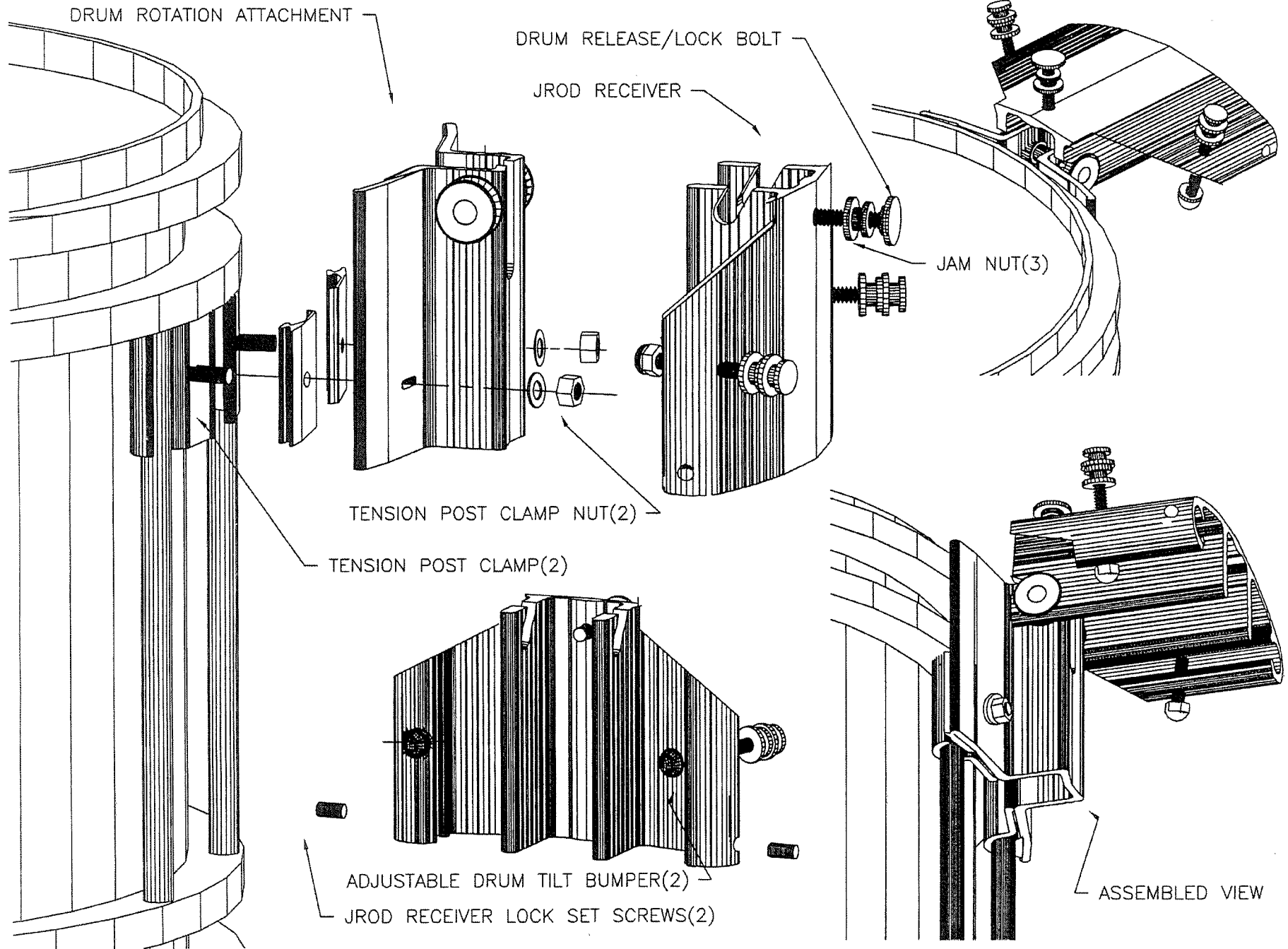

DRUM RELEASE/LOCK BOLT  
(SHOWN IN DRUM RELEASE POSITION)

RELEASE/INSERT POSITION

PLAYING POSITION

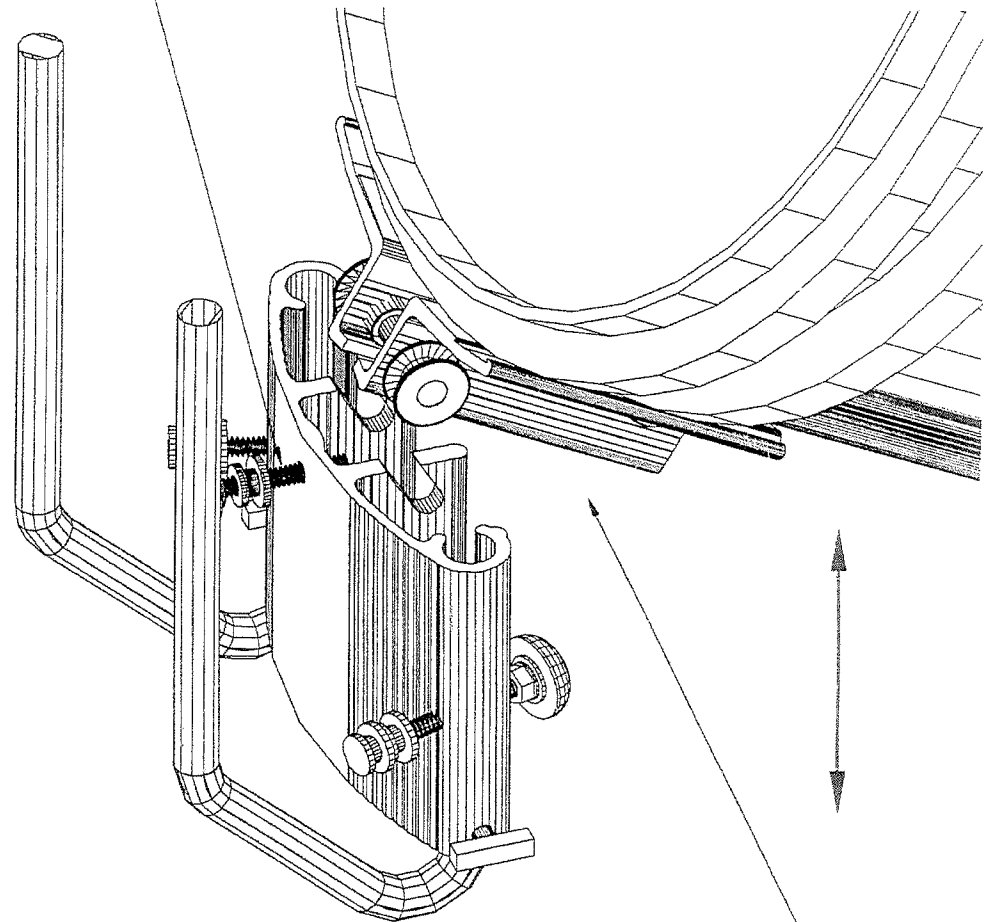
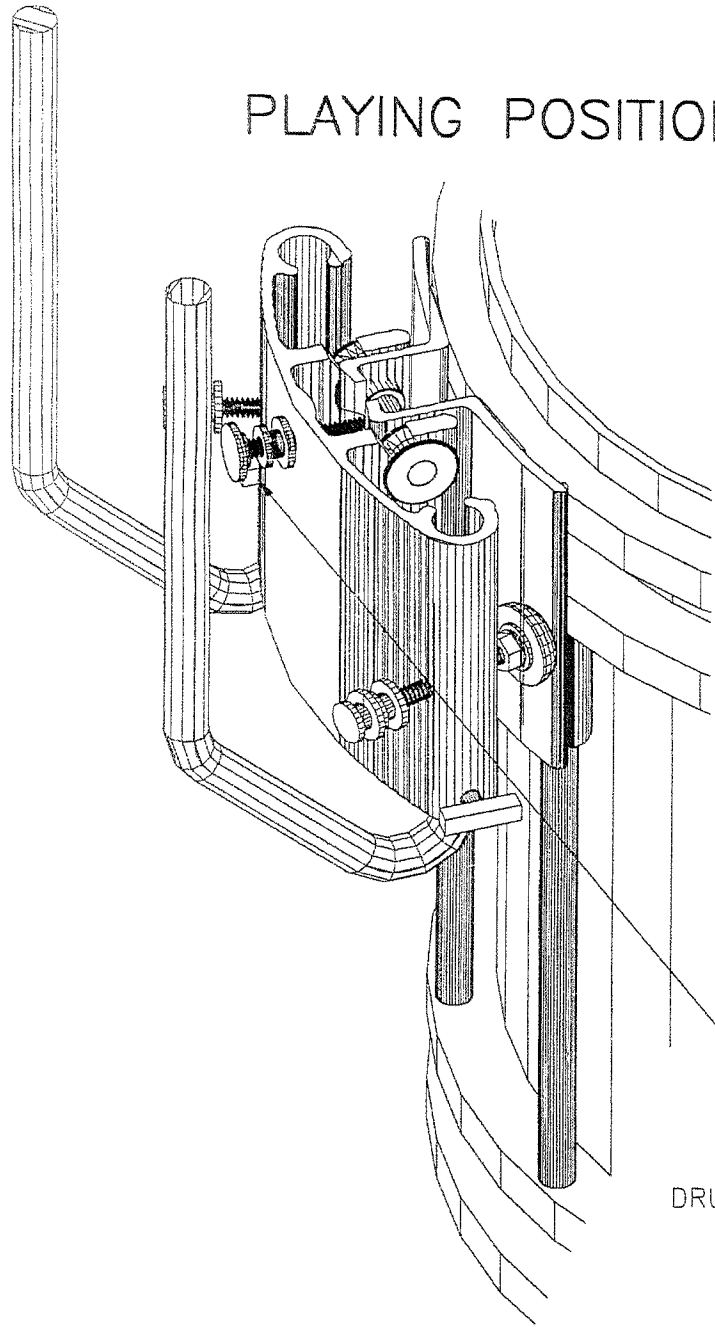

DRUM RELEASE/INSRT ANGLE

DRUM RELEASE/LOCK BOLT  
(SHOWN IN DRUM LOCK POSITION)  
DRUM IS READY TO ROTATE UP WITHOUT DISINGAGING

# OPTIONAL PLAYING POSITIONS

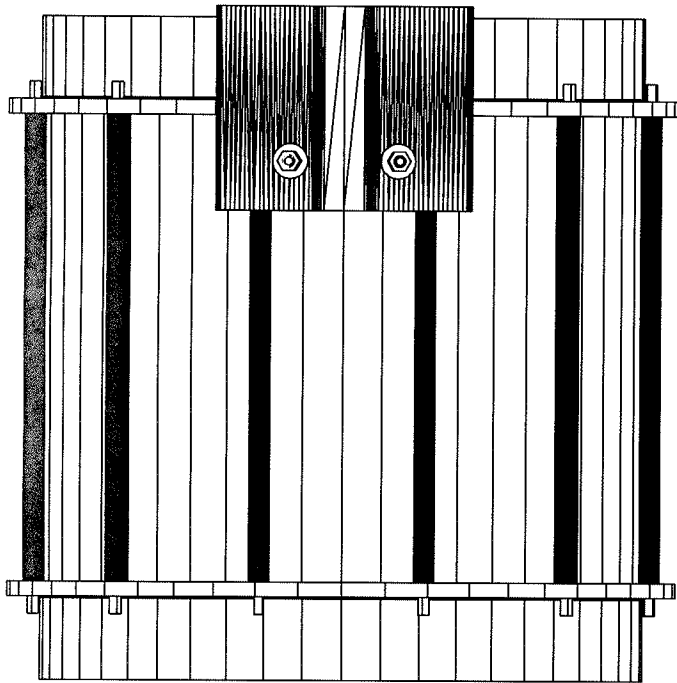

STANDARD

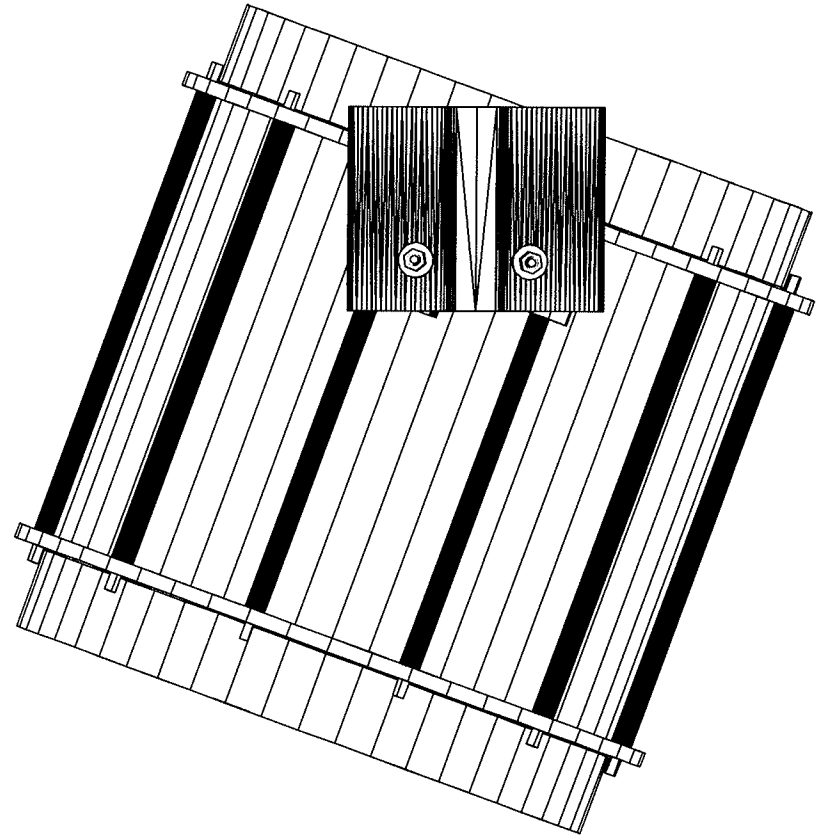

ANGLED

RM-FCSL-OP

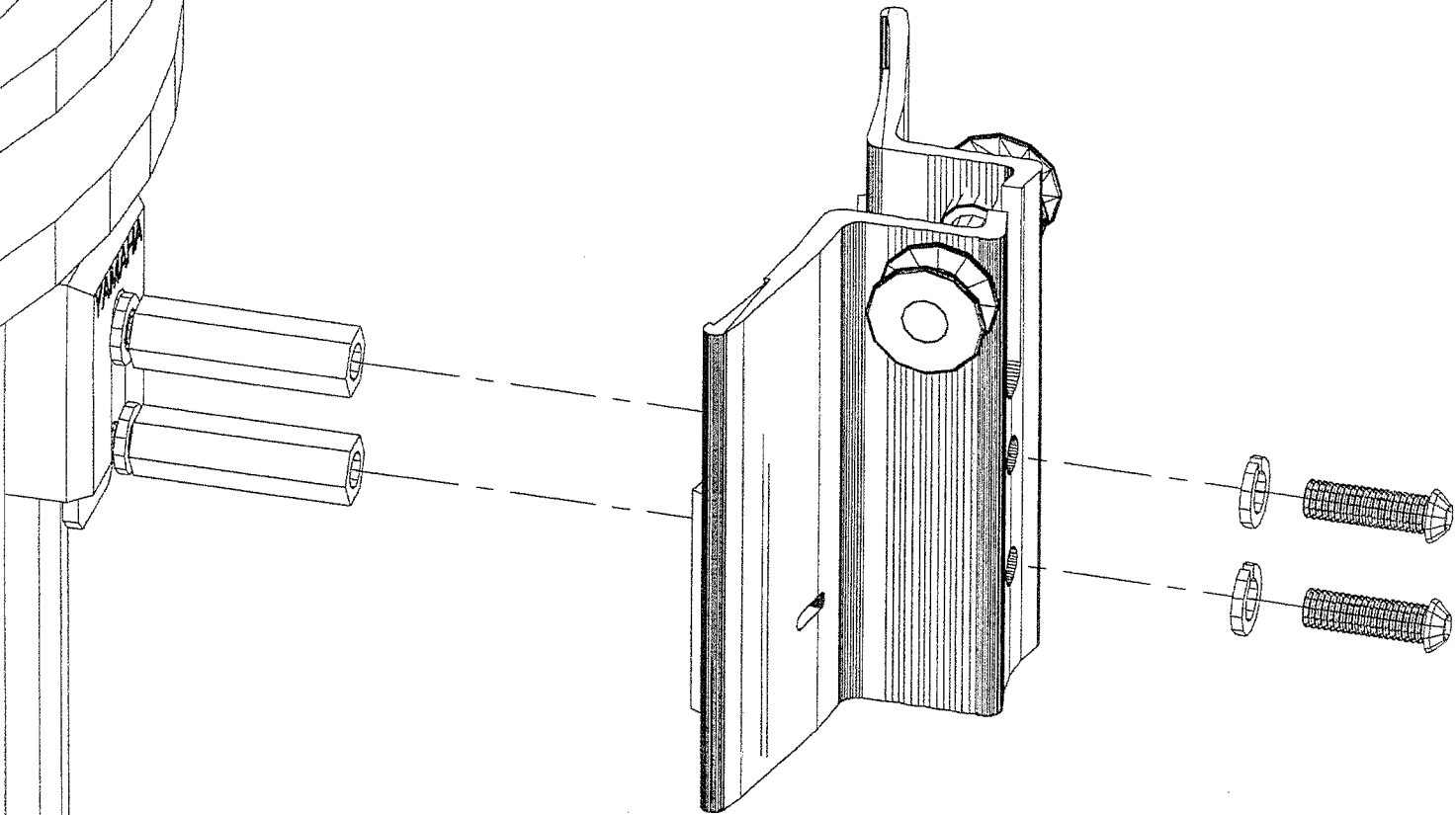
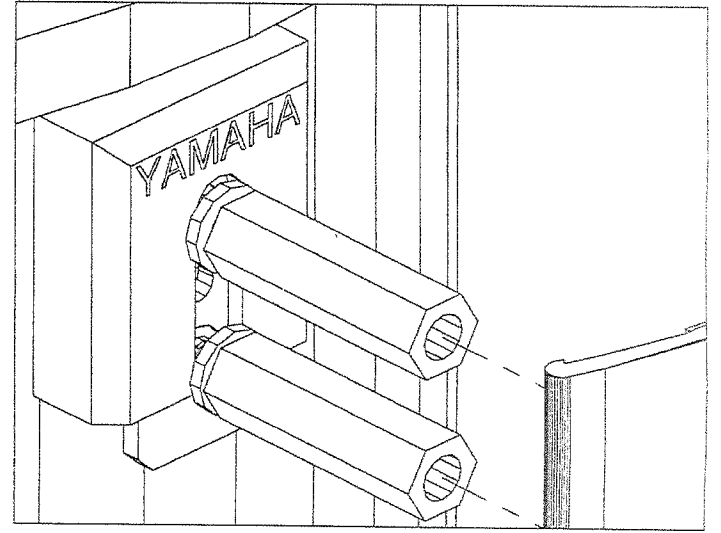

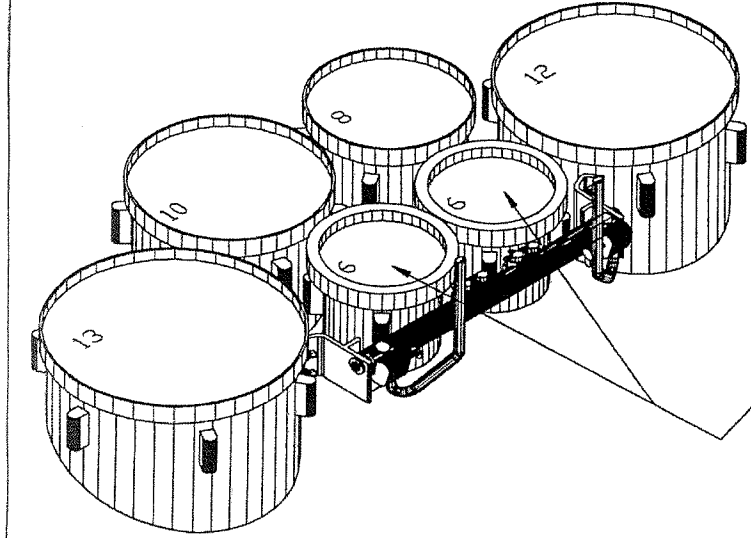

OPTIONAL 6" DRUM MOUNTS

RELEASE AREA FOR 6" DRUM MOUNT ATTACHMENT

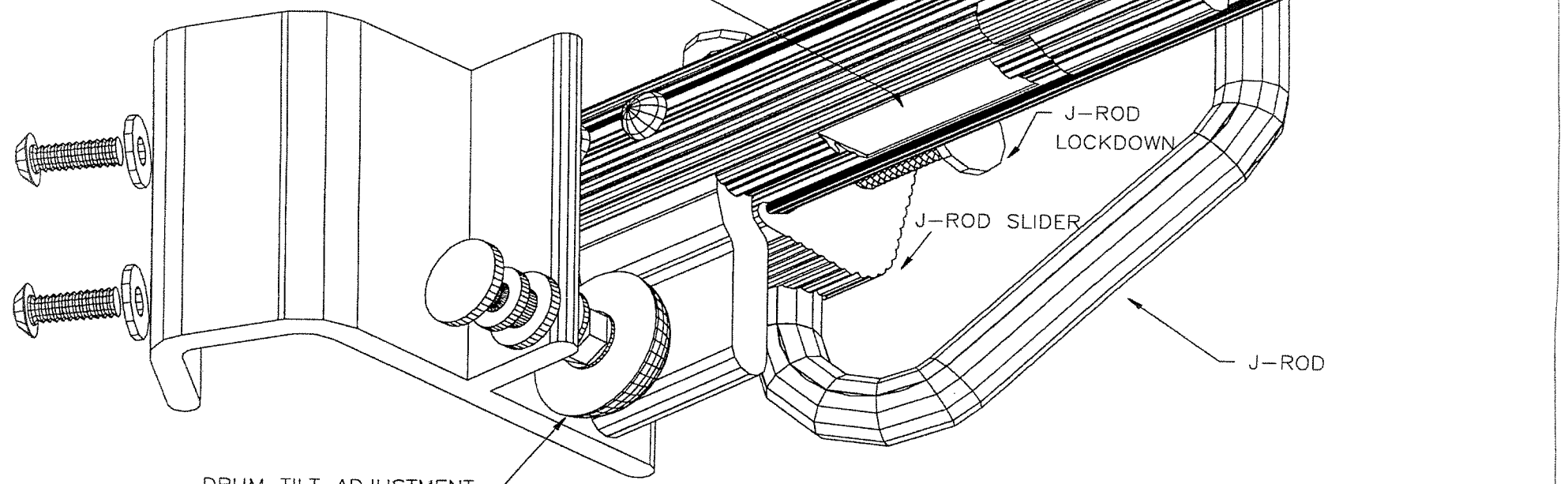

J-ROD  
LOCKDOWN

J-ROD  
SLIDER

J-ROD

DRUM TILT ADJUSTMENT

BOTTOM VIEW SHOWING CARRIER FEATURES

TOP VIEW AS SEEN BY PLAYER

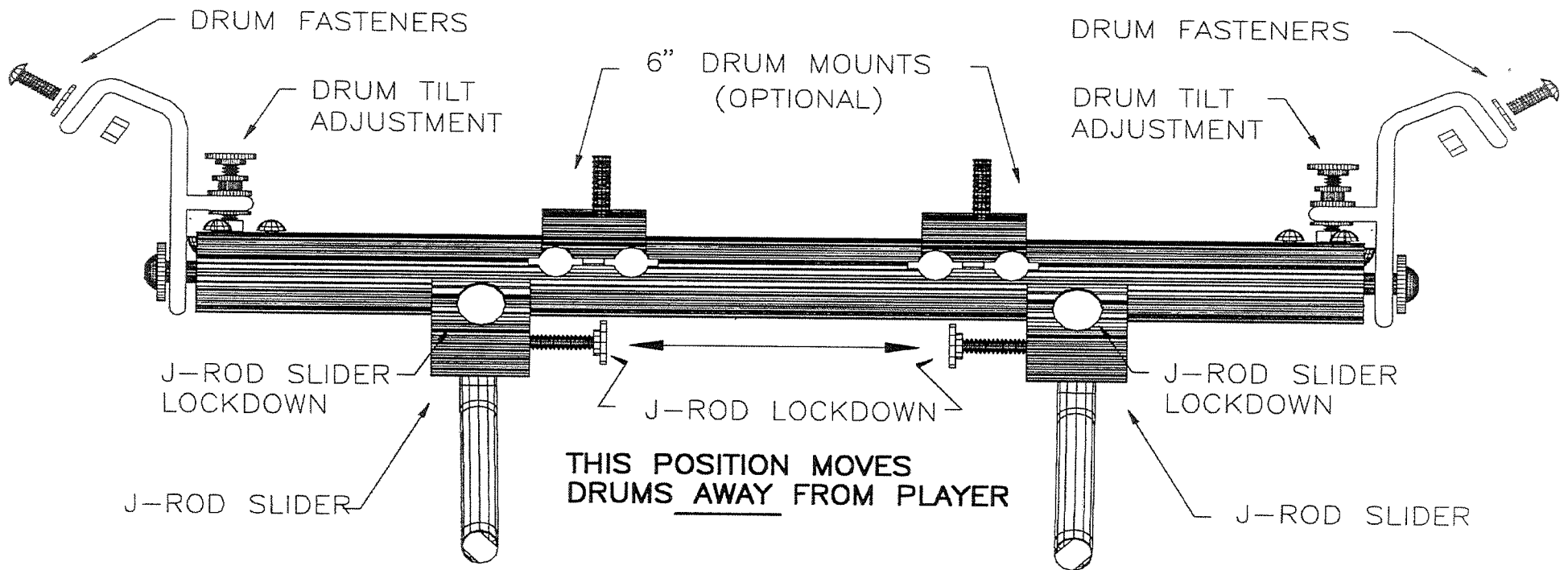
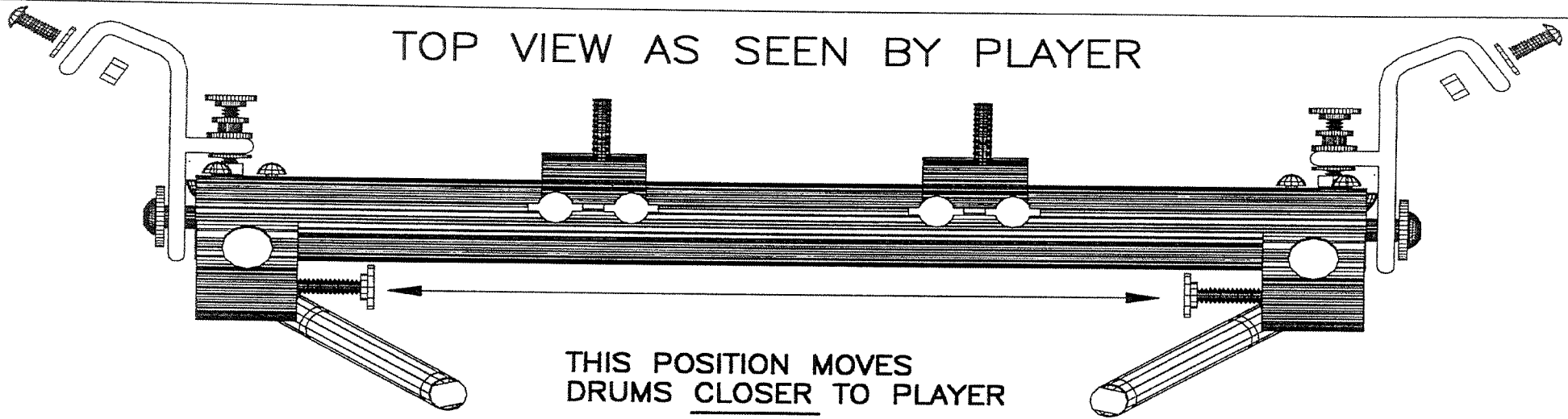

1. HOOK TOP OF DRUM MOUNT ATTACHMENT ON TO TOP TRACK OF CARRIER TUBE.
2. ROTATE DOWN UNTIL DRUM MOUNT ATTACHMENT IS RESTING ON BOTTOM OF CARRIER TUBE.
3. SLOWLY SLIDE TO RIGHT UNTIL BOTTOM OF DRUM MOUNT ATTACHMENT FINDS ON/OFF AREA.
4. SLIDE TO LEFT, DRUM MOUNT ATTACHMENT SHOULD BE ENGAGED AT THIS POINT.
5. SLIDE TO PREFERED PLAYING POSITION AND TIGHTEN (2) THUMB SCREWS.

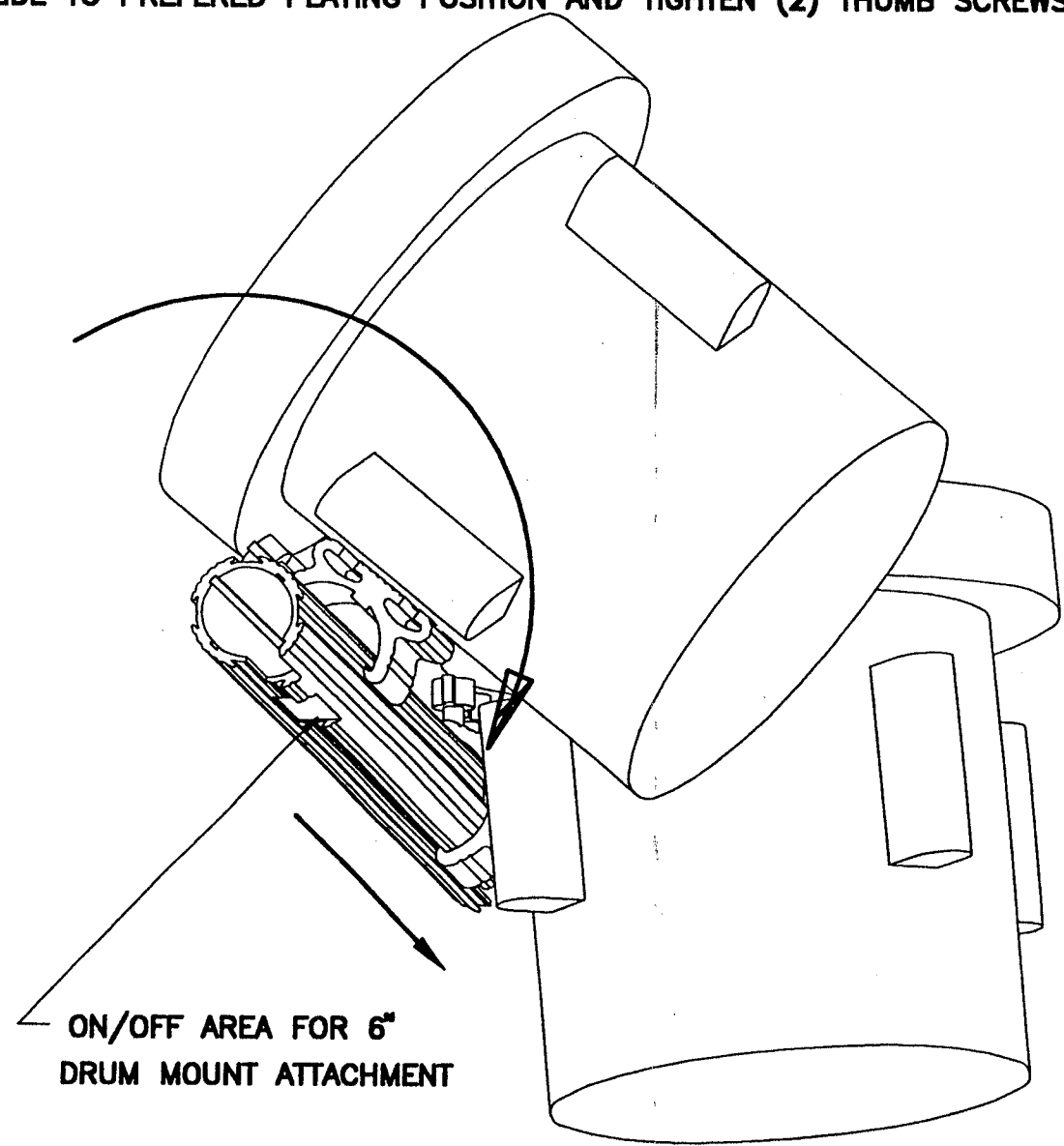
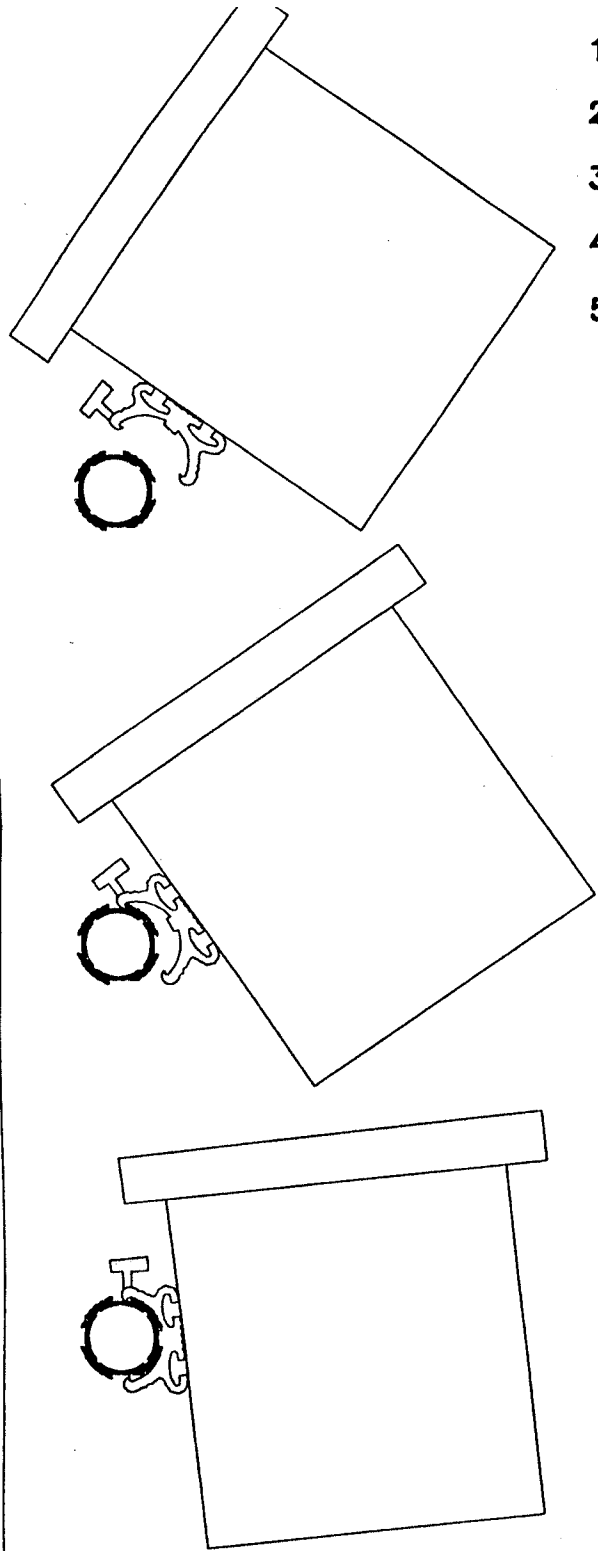

ON/OFF AREA FOR 6"  
DRUM MOUNT ATTACHMENT

BOTTOM VIEW SHOWING ATTACHING 6" DRUM

# OPTIONAL ADJUSTABLE BACK BAR (RM-ABB) AVAILABLE TO ADD ON ALL RM-ALT-MODELS.

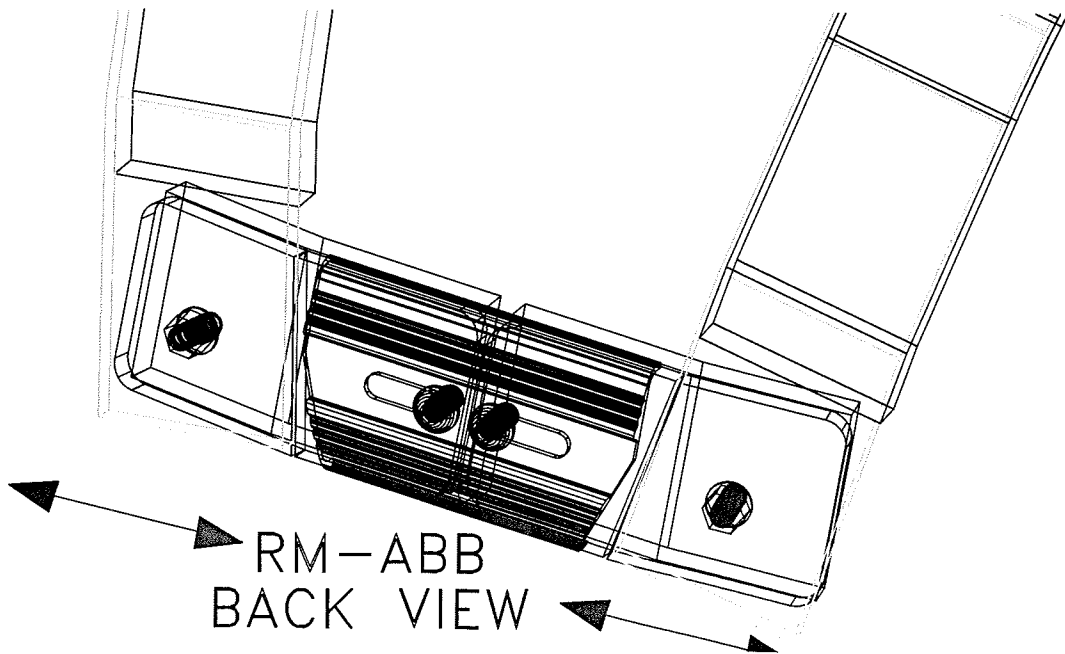
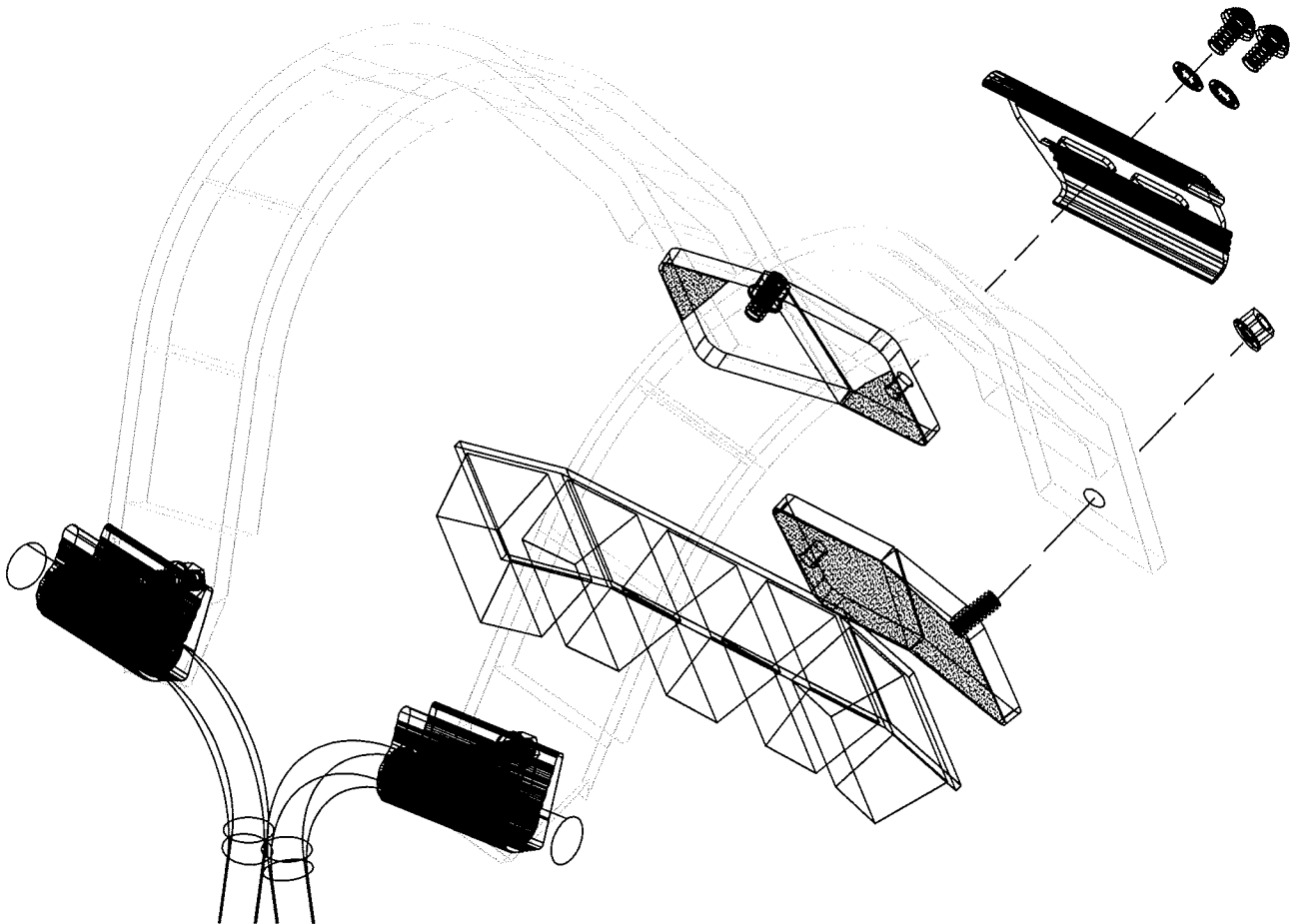



TO FURTHER LOWER DRUM VIA J-ROD POSITION,  
REMOVE NUTS AND ROTATE BELLY PLATE 180 DEG.

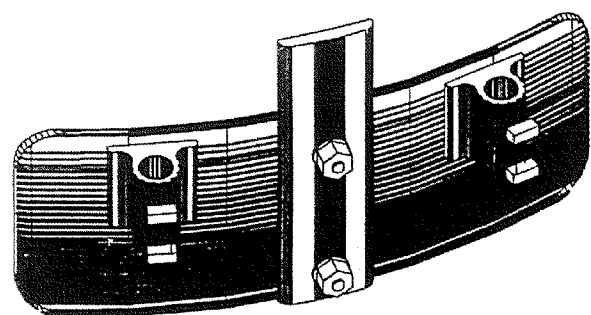
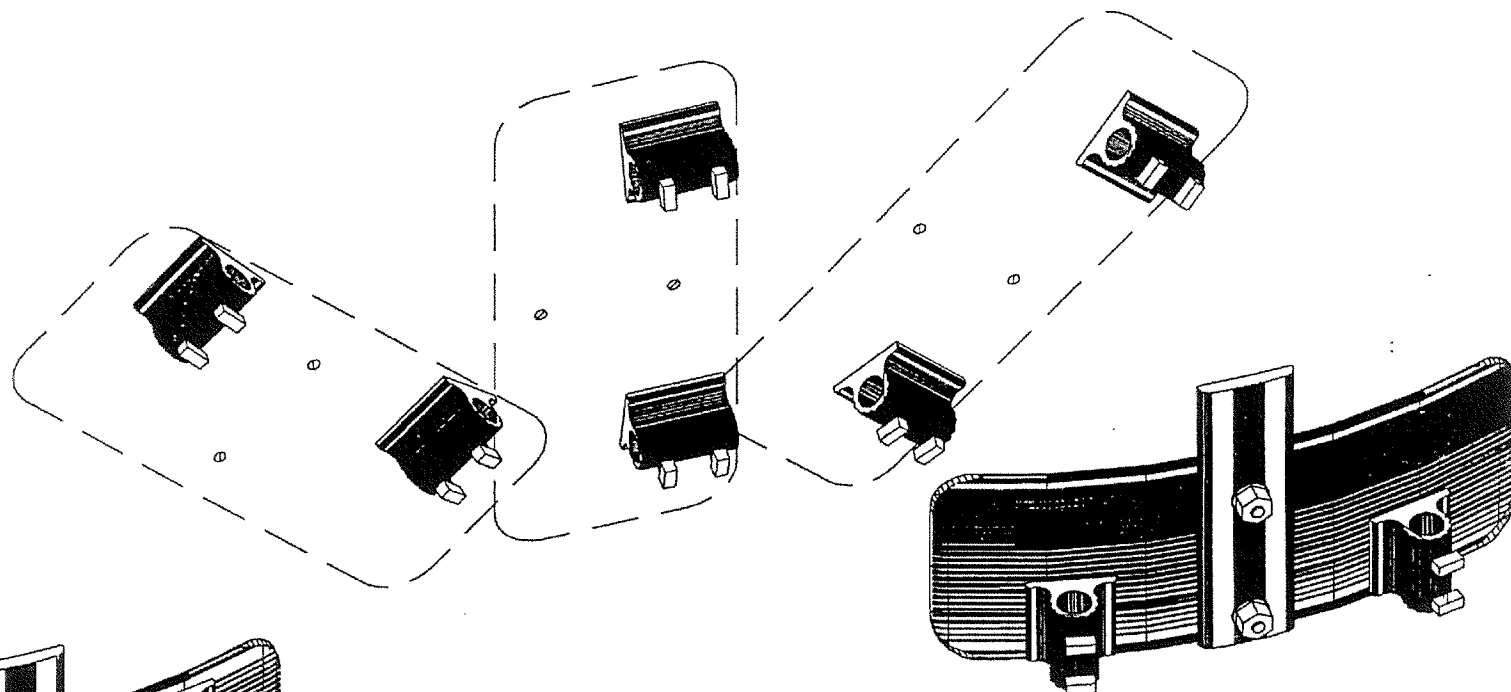

STANDARD POSITION

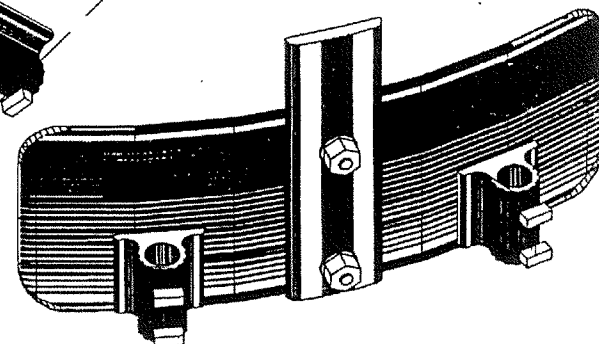

LOW POSITION

# SIZING INSTRUCTIONS FOR SHOULDER CONTOUR ADJUSTMENT SYSTEM.

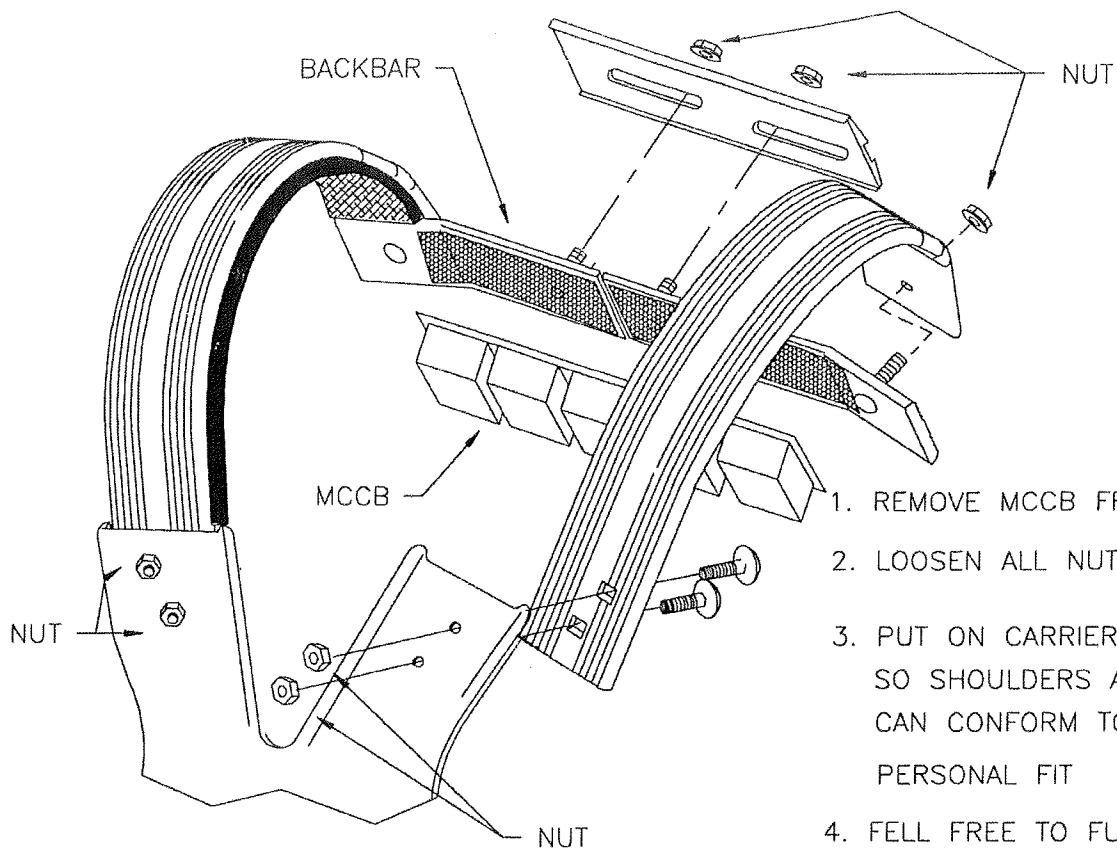

1. REMOVE MCCB FROM BACKBAR
2. LOOSEN ALL NUTS AS SHOWN
3. PUT ON CARRIER WITHOUT DRUM SO SHOULDERS AND BACKBAR CAN CONFORM TO YOUR PERSONAL FIT
4. FELL FREE TO FURTHER FINE TUNE YOUR CARRIER BY SLIDING SHOULDERS AND BACKBAR IN OR OUT FOR COMFORTABLE FIT.
5. WITH CARRER STILL ON HAVE ANOTHER PERSON TIGHTEN ALL NUTS.
6. REATTACH MCCB TO BACKBAR.

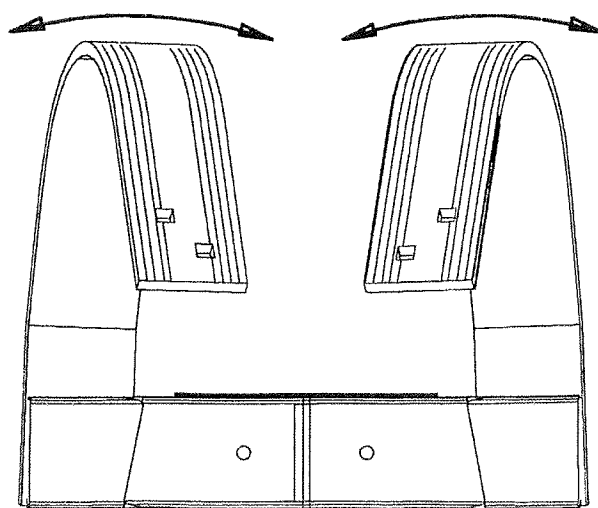
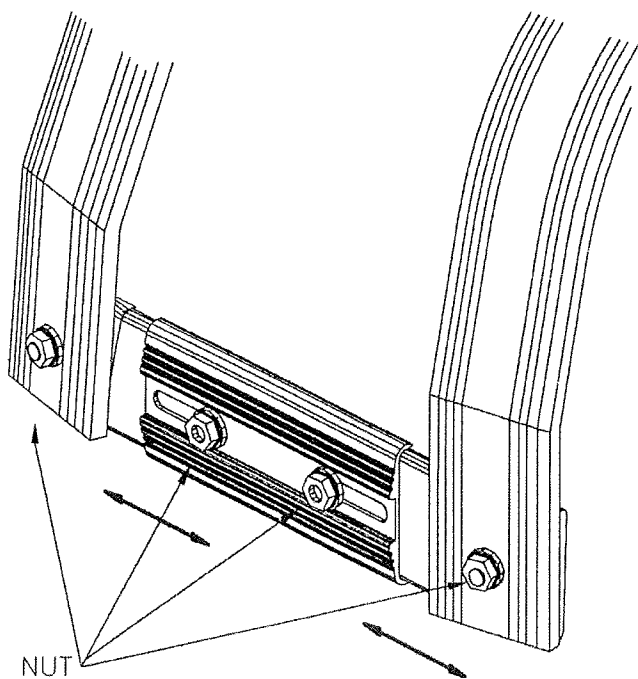

RMAVOPDX

RANDALL MAY INT'L., INC.