

YAMAHA *Clavinova*[®]

CLP-250

Owner's Manual
Bedienungsanleitung
Mode d'emploi
Manual de instrucciones

IMPORTANT

Check your power supply

Make sure that your local AC mains voltage matches the voltage specified on the name plate on the rear panel. In some areas a voltage selector may be provided on the rear panel of the main unit. Make sure that the voltage selector is set for the voltage in your area.

WICHTIG

Überprüfen der Netzspannung

Sicherstellen, daß die örtliche Netzspannung den Angaben zur Betriebsspannung auf der Rückseite des Keyboards entspricht. Die Modelle für einige Bestimmungsländer weisen einen Spannungswähler auf der Rückseite auf. In diesem Fall darauf achten, daß die Einstellung des Spannungswählers der Netzspannung entspricht.

IMPORTANT

Contrôler la source d'alimentation

S'assurer que la tension secteur locale correspond à la tension indiquée sur la plaque d'identification située sur le panneau arrière. Les modèles destinés à certaines régions peuvent être équipés d'un sélecteur de tension situé sur le panneau arrière de l'unité principale. Vérifier que le sélecteur est bien réglé pour la tension secteur utilisée.

IMPORTANTE

Verifique la alimentación de corriente

Asegúrese de que el voltaje local de CA concuerde con el especificado en la placa de identificación del panel trasero. En algunas áreas, la unidad viene provista de un selector de voltaje en el panel trasero. Asegúrese de que este selector esté en la posición correspondiente al voltaje de su área.

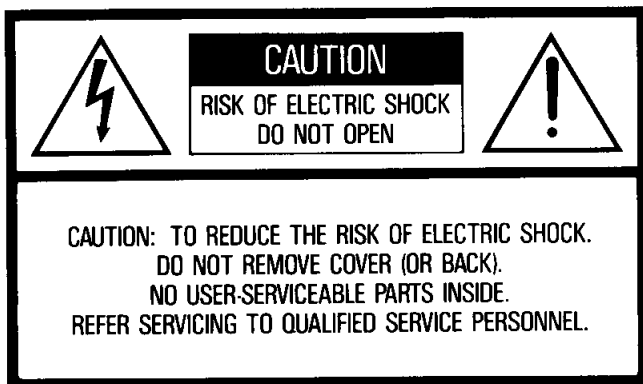

The lightning flash with arrowhead symbol, within an equilateral triangle, is intended to alert the user to the presence of uninsulated “dangerous voltage” within the product’s enclosure that may be of sufficient magnitude to constitute a risk of electric shock to persons.

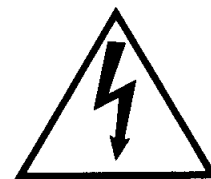

The exclamation point within an equilateral triangle is intended to alert the user to the presence of important operating and maintenance (servicing) instructions in the literature accompanying the product.



IMPORTANT SAFETY AND INSTALLATION INSTRUCTIONS

INFORMATION RELATING TO POSSIBLE PERSONAL INJURY, ELECTRIC SHOCK, AND FIRE HAZARD POSSIBILITIES HAS BEEN INCLUDED IN THIS LIST.

WARNING—When using electronic products, basic precautions should always be followed, including the following:

1. Read all Safety and Installation Instructions, Explanation of Graphical Symbols, and assembly instructions (where applicable) BEFORE using your Yamaha electronic product. Check unit weight specifications before you attempt to move this instrument!

2. Main Power Supply Verification: Your Yamaha electronic product has been manufactured specifically for the main supply voltage used in your area. If you should move, or if any doubt exists, please contact your dealer for instructions. The main supply voltage required by your electronic product is printed on the name plate. For name plate location, see preparation item.

3. This product may be equipped with a polarized line plug (one blade wider than the other). If you are unable to insert the plug into the outlet, contact an electrician to have your obsolete outlet replaced. Do NOT defeat the safety purpose of the plug. Yamaha products not having polarized plugs incorporate construction methods and designs that do not require line plug polarization.

4. **WARNING**—Do NOT place objects on your electronic product’s power cord or place the unit in a position where anyone could trip over, walk over, or roll anything over cords of any kind. Do NOT allow your electronic product or its bench to rest on or be installed over cords of any type. Improper installations of this type create the possibility of a fire hazard and/or personal injury.

5. Environment: Your electronic product should be installed away from heat sources such as a radiator, heat registers and/or other products that produce heat. Additionally, the unit should not be located in a position that exposes the cabinet to direct sunlight, or air currents having high humidity or heat levels.

6. Your Yamaha electronic product should be placed so that its location or position does not interfere with its proper ventilation.

7. Some Yamaha electronic products may have benches that are either a part of the product or supplied as an optional accessory. Some of these benches are designed to be dealer assembled. Please make sure that the bench is stable before using it. The bench supplied by Yamaha was designed for seating only. No other uses are recommended.

8. Some Yamaha electronic products can be made to operate with or without the side panels or other components that constitute a stand. These products should be used only with the components supplied or a cart or stand that is recommended by the manufacturer.

9. Do not operate for a long period of time at a high volume level or at a level that is uncomfortable. If you experience any hearing loss or ringing in the ears, you should consult an audiologist.

10. Do not use your Yamaha electronic product near water or in wet environments. For example, near a swimming pool, spa, or in a wet basement.

11. Care should be taken so that objects do not fall, and liquids are not spilled, into the enclosure through openings.

12. Your Yamaha electronic product should be serviced by a qualified service person when:

- The power-supply cord or plug has been damaged: or
- Objects have fallen, or liquid has been spilled into the product: or
- The product has been exposed to rain: or
- The product does not operate, exhibits a marked change in performance: or
- The product has been dropped, or the enclosure of the product has been damaged.

13. When not in use, always turn your Yamaha electronic product “OFF”. The power-supply cord of the product should be unplugged from the outlet when it is to be left unused for a long period of time. Notes: In this case, some units may lose some user programmed data. Factory programmed memories will not be affected.

14. Do not attempt to service the product beyond that described in the user-maintenance instructions. All other servicing should be referred to qualified service personnel.

15. Electromagnetic Interference (RFI). This series of Yamaha electronic products utilizes digital (high frequency pulse) technology that may adversely affect Radio/TV reception or the operation of other devices that utilize digital technology. Please read FCC Information (Page 32) for additional information.

**PLEASE KEEP THIS MANUAL
FOR FUTURE REFERENCE!**

Introduction

Thank you for choosing a Yamaha CLP-250 Clavinova. Your Clavinova is a fine musical instrument that employs advanced Yamaha music technology. With the proper care, your Clavinova will give you many years of musical pleasure.

- Yamaha's sophisticated AWM (Advanced Wave Memory) tone generator system offers rich, realistic reproductions of digitally sampled keyboard sounds.
 - Piano-like touch response provides extensive expressive control and outstanding playability.
 - MIDI compatibility and a range of MIDI functions make the Clavinova useful in a range of advanced MIDI music systems.
- In order to make the most of your Clavinova's performance potential and features, we urge you to read this Owner's Manual thoroughly, and keep it in a safe place for later reference.

Contents

Keyboard Stand Assembly	2	MIDI Transmit & Receive Channel Selection	9
TAKING CARE OF YOUR CLAVINOVA	6	MIDI FUNCTION CHART	10
THE CONTROLS AND CONNECTORS	6	Local Control ON/OFF	10
PREPARATION	7	Program Change ON/OFF	10
PLAYING THE CLAVINOVA	7	Control Change ON/OFF	10
TRANSPOSITION	8	TROUBLESHOOTING	11
PITCH CONTROL	8	OPTIONS & EXPANDER MODULES	11
MIDI FUNCTIONS	8	MIDI DATA FORMAT	11
A Brief Introduction to MIDI	8	SPECIFICATIONS	30
MIDI "Messages" Transmitted & Received by the Clavinova	9		

Vorwort

Herzlichen Dank für den Kauf des Yamaha Clavinovas CLP-250. Ihr Clavinova ist ein vielseitiges Keyboard, das mit modernster Yamaha Musiktechnologie arbeitet. Bei umsichtiger Handhabung wird es Ihnen viele Jahre Musikgenuss bieten.

- Das integrierte Yamaha AWM Wellenspeicher-Tongeneratorsystem erzeugt volle, natürlich klingende Stimmen auf der Basis von digital aufgezeichneten Keyboard-Klängen.
- Da das Clavinova die Anschlagsansprache eines Pianos besitzt, ist eine nuancenreiche Akzentuierung und ein umfassender musikalischer Ausdruck ermöglicht.
- Aufgrund der MIDI-Kompatibilität und der integrierten MIDI-Funktionen kann das Clavinova problemlos in komplexe MIDI-Systeme integriert werden.

Um das großartige Potential des Clavinovas voll ausschöpfen zu können, bitten wir Sie, diese Bedienungsanleitung sorgfältig zu lesen und zur späteren Bezugnahme an einem sicheren Ort aufzubewahren.

Inhalt

Zusammenbau des Keyboardständers und Aufstellung	2	Lokalsteuerung AN/AUS	16
PFLERGE DES CLAVINOVAS	12	Programmwechsel AN/AUS	16
BEDIENELEMENTE UND ANSCHLÜSSE	12	Steuerelement AN/AUS	16
VORBEREITUNG	13	FEHLERSUCHE	17
SPIELEN AUF DEM CLAVINOVA	14	SONDERZUBEHÖR & ERWEITERUNGSMODULE	17
TRANSPOSITION	14	MIDI-DATENFORMAT	17
EINSTIMMFUNKTION	14	TECHNISCHE DATEN	30
MIDI-FUNKTIONEN	14		
Eine kurze Einführung in MIDI	14		
Vom Clavinova übertragene und empfangene MIDI-Meldungen	15		
Wahl des MIDI-Sende/Empfangskanals	15		
MIDI-FUNKTIONSLISTE	16		

Introduction

Nous vous remercions d'avoir choisi le Clavinova Yamaha CLP-250. Le Clavinova est un instrument de musique perfectionné faisant appel aux innovations les plus récentes de la technologie musicale mise au point par Yamaha. Si vous utilisez votre Clavinova avec le soin qui convient, il vous donnera de grandes satisfactions pendant de longues années.

- Le système générateur de sons AWM (de l'anglais Advanced Wave Memory) ultra-sophistiqué de Yamaha permet une reproduction riche et réaliste des sons de clavier échantillonnés numériquement.
- Une réponse au toucher similaire à celle d'un piano vous permet un plus grand contrôle de l'expression et vous offre des possibilités d'exécution extraordinaires.
- La compatibilité MIDI et toute une série de fonctions MIDI permettent d'utiliser le Clavinova dans de très nombreux systèmes musicaux MIDI.

Afin d'obtenir du Clavinova le maximum des possibilités et fonctions qu'il offre, nous vous conseillons de lire attentivement ce manuel d'instructions et de le conserver dans un endroit sûr afin de pouvoir vous y référer si besoin est.

Table des matières

Support du clavier	3	Activation/Désactivation de changement de commande	22
ENTRETIEN DU CLAVINOVA	18	DEPISTAGE DES PANNES	23
COMMANDES ET CONNECTEURS	18	OPTIONS ET MODULES EXPANDEURS	23
PREPARATIFS	19	FORMAT DES DONNEES MIDI	23
EXECUTION SUR LE CLAVINOVA	20	SPECIFICATIONS	30
TRANSPOSITION	20		
REGLAGE DE LA HAUTEUR TONALE	20		
FONCTIONS MIDI	20		
Quelques mots sur l'interface MIDI	20		
"Messages" MIDI transmis et reçus par le Clavinova	21		
Sélection des canaux MIDI de transmission et de réception	21		
TABLEAU DE FONCTIONS MIDI	22		
Activation/Désactivation de commande locale	22		
Activation/Désactivation de changement de programme	22		

Introducción

Gracias por su elección de la Yamaha Clavinova CLP-250. Su Clavinova es un instrumento musical de calidad que emplea la avanzada tecnología musical de Yamaha. Con un trato adecuado, le brindará muchos años de satisfacciones musicales.

- El sofisticado sistema generador de tonos AWM (Advanced Wave Memory, o Memoria Avanzada de Onda) de Yamaha ofrece una rica y fiel reproducción de sonidos de teclado muestreados digitalmente.
- Una respuesta al toque similar a la del piano brinda un amplio control expresivo y notable facilidad de ejecución.
- Su compatibilidad con el sistema MIDI, y sus variadas funciones MIDI, hacen de la Clavinova un útil componente en cualquier sistema musical MIDI avanzado.

A fin de aprovechar al máximo las posibilidades y funciones de su Clavinova, le recomendamos leer este manual de instrucciones atentamente y guardarlo en lugar seguro para referencias futuras.

Índice

Armado del soporte del teclado	3	Activación y desactivación del control local	28
CUIDADO DE SU CLAVINOVA	24	Activación y desactivación del cambio de programa	28
CONTROLES Y CONECTORES	24	Activación y desactivación del cambio de control	28
PREPARACION	25	ALGUNOS PROBLEMAS TÍPICOS Y COMO SOLUCIONARLOS	29
TOCANDO LA CLAVINOVA	26	OPCIONALES Y MÓDULOS DE EXPANSION	29
TRANSPOSICION	26	FORMATO DE LOS DATOS MIDI	29
CONTROL DE ALTURA	26	ESPECIFICACIONES	30
FUNCIONES MIDI	26		
Una breve introducción al sistema MIDI	26		
"Mensajes" MIDI transmitidos y recibidos por la Clavinova	27		
Selección de canales de transmisión y recepción MIDI	27		
TABLA DE FUNCIONES MIDI	28		

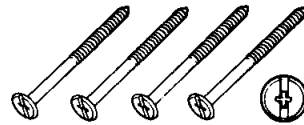
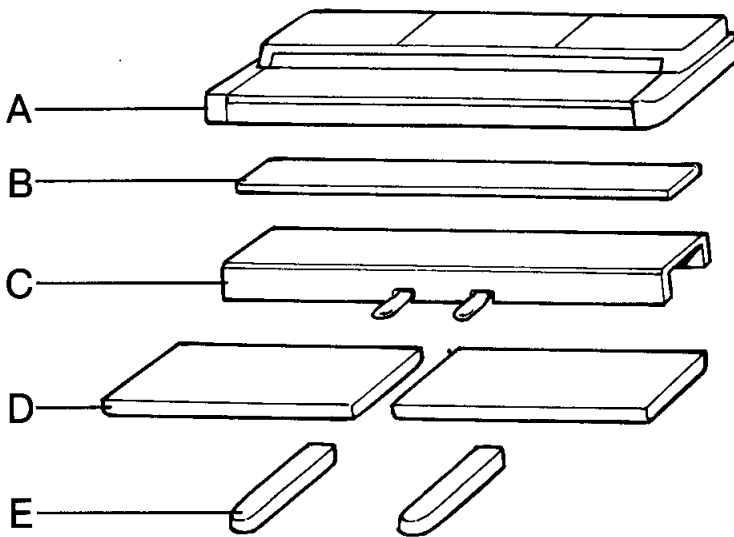
1

- Long screws (black) × 4
- Lange Schrauben (schwarz) × 4
- Vis longues (noires) × 4
- Tornillos largos (negros) × 4



- Short large-head screws (black) × 4
- Kurze Schrauben mit großem Kopf (schwarz) × 4
- Vis courtes à grosse tête (noires) × 4
- Tornillos cortos de cabeza grande (negros) × 4

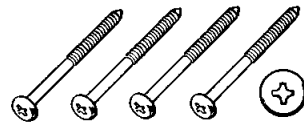

- Long screws (gold) × 4
- Lange Schrauben (goldfarben) × 4
- Vis longues (dorées) × 4
- Tornillos largos (dorados) × 4



- Short screws (black) × 4
- Kurze Schrauben (schwarz) × 4
- Vis courtes (noires) × 4
- Tornillos cortos (negros) × 4



- Joint connectors × 8
- Verbindungsstücke × 8
- Dispositifs d'assemblage × 8
- Juntas × 8

Keyboard Stand Assembly

1 Open the box and remove all the parts.

On opening the box you should find the parts shown in the illustration. Check to make sure that all the required parts are provided.

2 Assemble the side panels (D) and base boards (E).

Install the joint connectors in side panels (D) as shown in the illustration, then secure the base boards (E) to the side panels (D) with the long gold-colored screws.

* When installing the joint connectors in the holes in the side panels (D), make sure that the arrows printed on their upper surface face in the direction shown in the illustration.

* Make sure that the left and right base boards are facing in the proper direction as shown in the illustration. The grooved edge of each base board should face inward.

3 Attach the side panels (D) to the pedal box (C).

Place the pedal box on top of the brackets attached to the side panels (D), and attach using the four short large-head black-colored screws.

4 Attach the rear panel (B) to the side panels (D).

Insert four joint connectors into the four holes at the rear side of the rear panel (B) (two holes on each side). Then secure the rear panel (B) to the side panels (D) using the four long black-colored screws.

* When installing the joint connectors in the holes in the rear panel (B), make sure that the arrows printed on their upper surface face in the direction shown in the illustration.

Zusammenbau des Keyboardständers und Aufstellung

1 Den Versandkarton öffnen und alle Teile auspacken.

Der Versandkarton sollte alle in der Abbildung gezeigten Teile enthalten. Sicherstellen, daß alle benötigten Teile vorhanden sind.

2 Die Seitenplatten (D) und Füße (E) zusammenbauen.

Die Verbindungsstücke entsprechend der Abbildung in die Seitenplatten (D) einsetzen. Dann die Füße (E) mit den langen goldfarbenen Schrauben an den Seitenplatten (D) anbringen.

* Beim Einsetzen der Verbindungsstücke in die Bohrungen der Seitenplatten (D) sicherstellen, daß die Pfeile auf den Oberseiten wie in der Abbildung ausgerichtet sind.

* Sicherstellen, daß linke und rechte Sockelplatte in die in der Abbildung gezeigten Richtung weisen. Die Fußkante mit der Nut sollte dabei nach innen weisen.

3 Die Seitenplatten (D) an der Pedalkonsole (C) anbringen.

Die Pedalkonsole auf die Halterungen an den Seitenplatten (D) aufsetzen und durch Eindrehen der vier kurzen schwarzen Schrauben mit großem Kopf befestigen.

4 Die Rückwand (B) an den Seitenplatten (D) anschrauben.

Die vier Verbindungsstücke in die vier Löcher der Rückwand (B) (zwei Löcher auf jeder Seite) einsetzen und dann die Rückwand (B) mit den vier langen schwarzen Schrauben an den Seitenplatten (D) anschrauben.

* Beim Einsetzen der Verbindungsstücke in die Bohrungen der Rückwand (B) sicherstellen, daß die Pfeile auf den Oberseiten wie in der Abbildung ausgerichtet sind.

2

- Joint connectors
- Verbindungsstücke
- Dispositifs d'assemblage
- Juntas

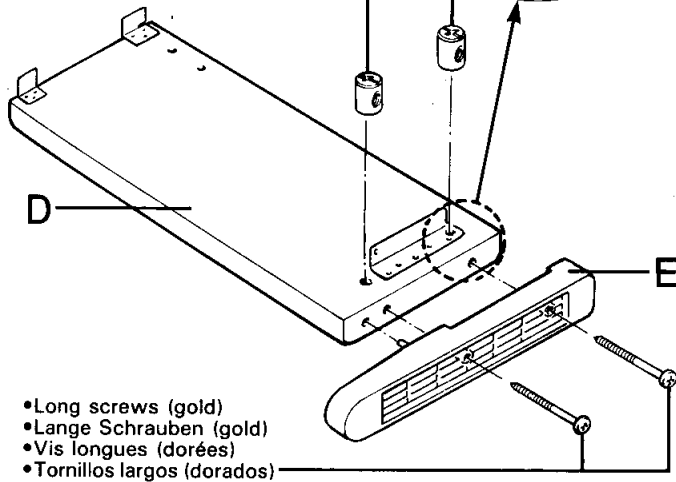

- Long screws (gold)
- Lange Schrauben (gold)
- Vis longues (dorées)
- Tornillos largos (dorados)

3, 4

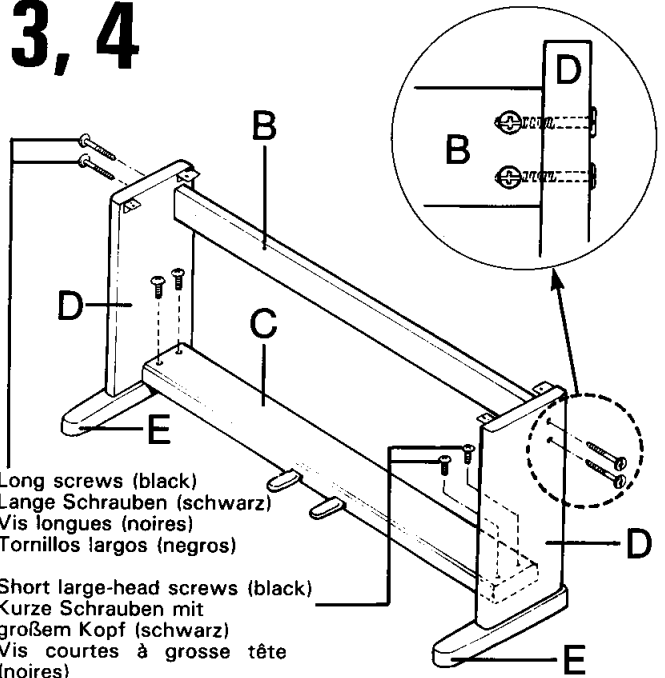

- Long screws (black)
- Lange Schrauben (schwarz)
- Vis longues (noires)
- Tornillos largos (negros)

- Short large-head screws (black)
- Kurze Schrauben mit großem Kopf (schwarz)
- Vis courtes à grosse tête (noires)
- Tornillos cortos de cabeza grande (negros)

Support du clavier

1 Ouvrir le carton et retirer toutes les pièces

Les pièces indiquées sur l'illustration devraient toutes se trouver dans le carton. Vérifier qu'il n'en manque aucune.

2 Monter les panneaux latéraux (D) sur les supports inférieurs (E)

Poser les dispositifs d'assemblage sur les panneaux latéraux (D) de la manière illustrée, puis fixer les supports inférieurs (E) aux panneaux latéraux (D) à l'aide des vis longues dorées.

* Lors de la pose des dispositifs d'assemblage dans les trous des panneaux latéraux (D), veiller à ce que les flèches marquées sur leurs surfaces supérieures pointent dans le sens indiqué sur l'illustration.

* Veiller à ce que les supports droit et gauche soient orientés de la manière illustrée. Le bord découpé de chaque support doit être dirigé vers l'intérieur.

3 Fixer les panneaux latéraux (D) au pédalier (C)

Placer le pédalier sur les ferrures des panneaux latéraux (D) et le fixer à l'aide des quatre vis courtes à grosse tête de couleur noire.

4 Fixer le panneau arrière (B) aux panneaux latéraux (D)

Introduire un dispositif d'assemblage dans chacun des quatre trous de la face arrière du panneau arrière (B) (deux trous de chaque côté). Fixer ensuite le panneau arrière (B) aux panneaux latéraux (D) à l'aide des quatre vis courtes à grosse tête de couleur noire.

* Lors de la pose des dispositifs d'assemblage dans les trous des panneaux latéraux (D), veiller à ce que les flèches marquées sur leurs surfaces supérieures pointent dans le sens indiqué sur l'illustration.

Armado del soporte del teclado

1 Abra la caja y extraiga todas las partes.

En la caja deberá encontrar todas las partes mostradas en la ilustración. Confirme que todas las partes necesarias estén incluidas.

2 Una los paneles laterales (D) con los tableros de base (E).

Coloque las juntas de los paneles laterales (D) como se aprecia en la ilustración, y fije los tableros de base (E) a los paneles laterales (D) con los tornillos largos dorados.

* Cuando coloque las juntas en los orificios de los paneles laterales (D), asegúrese de que las flechas impresas en su superficie superior apunten en la dirección mostrada en la ilustración.

* Asegúrese de que los tableros de base izquierdo y derecho queden en la dirección correcta como se ve en la ilustración. El borde ranurado de cada base debe quedar hacia adentro.

3 Una los paneles laterales (D) a la caja de pedales (C).

Ubique la caja de pedales sobre las ménsulas unidas a los paneles laterales (D), y fijela mediante los cuatro tornillos negros de cabeza grande.

4 Una el panel trasero (B) a los paneles laterales (D).

Inserte cuatro juntas en los cuatro orificios del lado posterior del panel trasero (B) (dos orificios a cada lado). Después, fije el panel trasero a los paneles laterales (D) con los cuatro tornillos negros largos.

* Cuando coloque las juntas en los orificios del panel trasero (B), asegúrese de que las flechas impresas en su superficie superior apunten en la dirección mostrada en la ilustración.

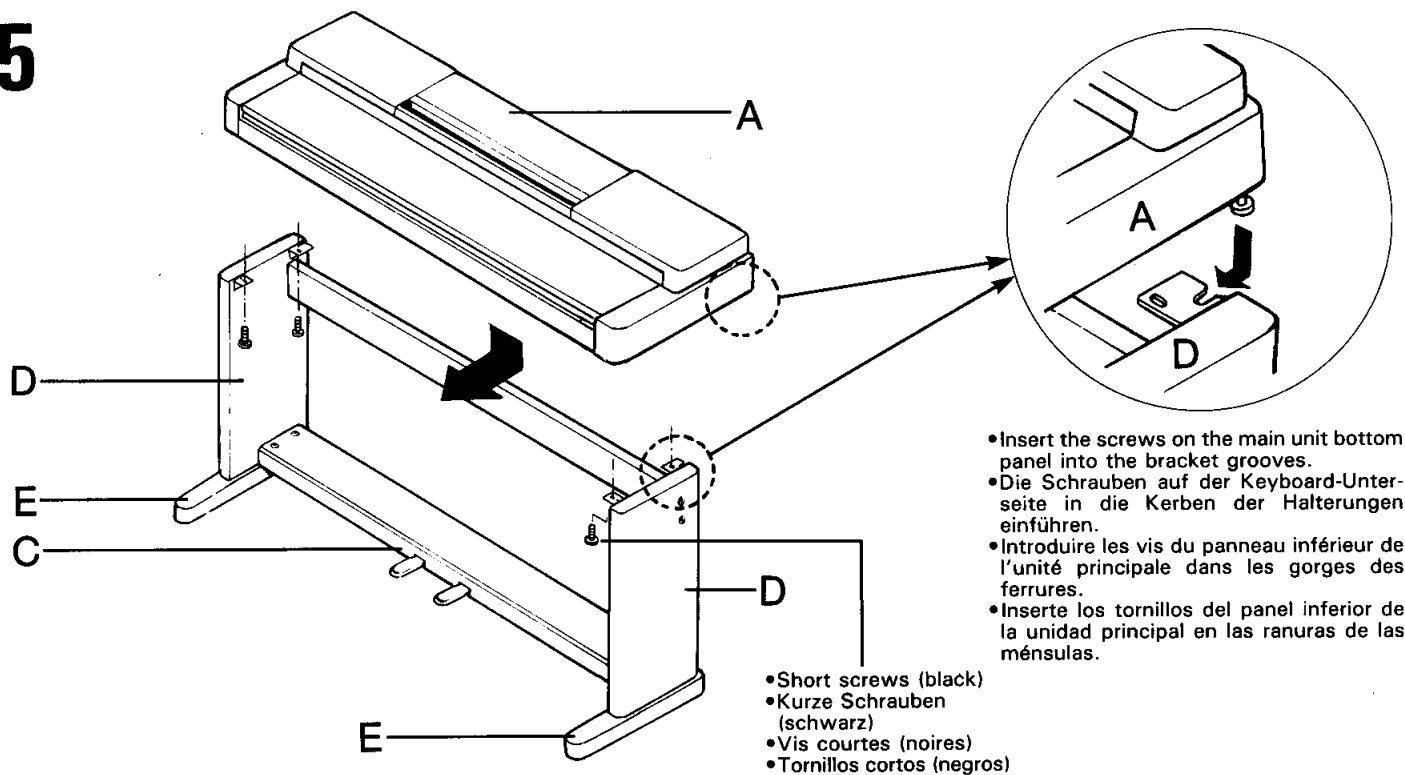
5

- Insert the screws on the main unit bottom panel into the bracket grooves.
- Die Schrauben auf der Keyboard-Unterseite in die Kerben der Halterungen einführen.
- Introduire les vis du panneau inférieur de l'unité principale dans les gorges des ferrures.
- Inserte los tornillos del panel inferior de la unidad principal en las ranuras de las ménsulas.

- Short screws (black)
- Kurze Schrauben (schwarz)
- Vis courtes (noires)
- Tornillos cortos (negros)

5 Install the main unit (A).

Place the main unit on the side panels (D) with the screws on its bottom panel (toward the rear of the main unit) just behind the grooves in the brackets located at the top of the side panels (D), then slide the keyboard forward until it stops.

Align the holes on the bottom panel of the main unit (A) with the holes in the brackets on the side panels (D), then screw in and securely tighten the four short black-colored screws.

6 Connect the pedal cords.

Attach the pedal cord to the two pedal cord holders located on the side panel, then insert the pedal cord plug into the connector located at the bottom of the main unit's rear panel.

* Check to make sure that all screws have been securely tightened.

7 Be sure to set the adjuster.

For stability, an adjuster is provided on the bottom of the pedal box (C). Rotate the adjuster until it comes in firm contact with the floor surface. The adjuster ensures stable pedal operation and facilitates pedal effect control.

* If the adjuster is not in firm contact with the floor surface, distorted sound may result.

5 Keyboard (A) installieren.

Das Keyboard so auf die Seitenplatten (D) aufsetzen, daß die Schrauben auf der Bodenplatte (hinten) genau hinter den Kerben der Halterungen auf den Seitenplatten (D) zu liegen kommen. Dann das Keyboard bis zum Anschlag nach vorne schieben.

Die Löcher in der Bodenplatte des Keyboards (A) mit den Löchern in den Halterungen auf den Seitenplatten (D) ausrichten und die vier kurzen schwarzen Schrauben fest hineindreihen.

6 Die Pedalkonsole anschließen.

Das Pedalkabel in die zwei Kabelhalter auf der Seitenplatte einsetzen und dann den Stecker des Pedalkabels in die Buchse unten auf der Rückseite des Keyboards einführen.

* Sicherstellen, daß alle Schrauben gut festgezogen sind.

7 Unbedingt die Stützschraube einstellen.

Um eine gute Stabilität zu gewährleisten, befindet sich unten an der Pedalkonsole (C) ein Stützschaube. Die Stützschaube drehen, bis sie den Boden berührt. Die Stützschaube verhindert ein Verrutschen der Pedalkonsole beim Spielen und vereinfacht die Effektsteuerung über Pedal.

* Falls die Stützschaube nicht fest am Boden aufsitzt, kann es zu Klangverzerrungen kommen

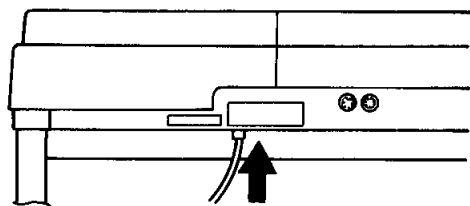
6

- Cord holder
- Pedalkabelhalter
- Monture de cordon
- Soportes de cable

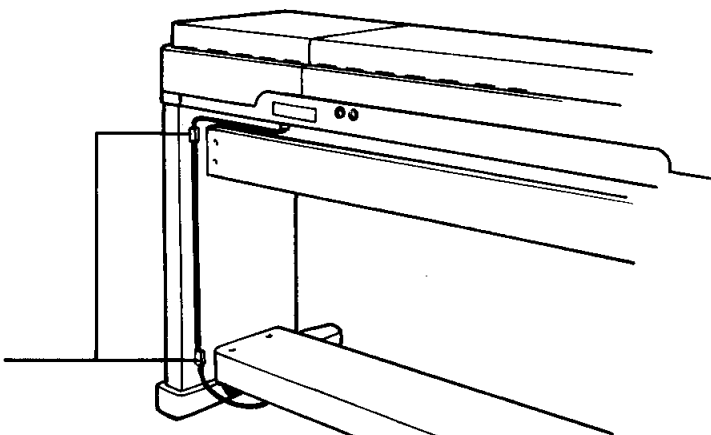
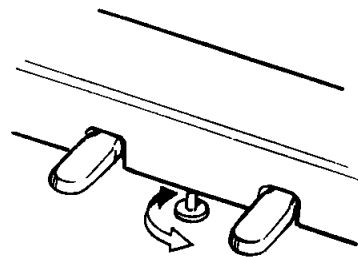
**7**

- Rotate the adjuster until it comes in firm contact with the floor surface.
- Die Stützschaube drehen, bis sie fest am Boden aufsitzt.
- Tourner le dispositif de réglage jusqu'à ce qu'il soit en contact ferme avec la surface du sol.
- Gire el ajustador hasta que quede en firme contacto con la superficie del piso.

5 Poser l'unité principale (A)

Placer l'unité principale sur les panneaux latéraux (D), avec les vis de son panneau inférieur (situées vers l'arrière de l'unité principale) placées immédiatement derrière les gorges des ferrures situées à la partie supérieure des panneaux latéraux (D), puis faire glisser le clavier vers l'avant jusqu'à ce qu'il vienne en butée.

Aligner les trous du panneau inférieur de l'unité principale (A) sur les trous des ferrures des panneaux latéraux (D), puis introduire et serrer à fond les quatre vis courtes de couleur noire.

6 Connecter le cordon de pédale

Fixer le cordon de pédale aux deux montures de cordon de pédale situées sur le panneau arrière. Insérer ensuite la fiche du cordon de pédale dans le connecteur situé à la partie inférieure du panneau arrière de l'unité principale.

* Vérifier que toutes les vis sont serrées à fond.

7 Ne pas oublier de régler la hauteur du pédalier!

Pour assurer la stabilité du pédalier, un dispositif de réglage est prévu à sa partie inférieure. Tourner le jusqu'à ce qu'il soit en contact ferme avec la surface du sol. Ce dispositif assure la stabilité du pédalier lors de son utilisation et facilite la commande au pied des effets.

* Si ce dispositif n'est pas en contact ferme avec le sol, il peut se produire une distorsion du son.

5 Instale la unidad principal (A).

Coloque la unidad principal sobre los paneles laterales (D) con los tornillos de su panel inferior (hacia la parte trasera de la unidad principal) colocados justo detrás de las ranuras de las ménsulas ubicadas en la parte superior de los paneles laterales (D), y deslice el teclado hacia adelante hasta el tope.

Alinee los orificios del panel inferior de la unidad principal (A) con los orificios de las ménsulas de los paneles laterales (D), y atornille los cuatro tornillos negros largos, apretándolos firmemente.

6 Conecte el cable de los pedales.

Fije el cable de los pedales a los dos soportes ubicados en el panel lateral, e inserte la clavija del cable de los pedales en el conector ubicado en la parte inferior del panel trasero de la unidad principal.

* Confirme que todos los tornillos estén firmemente apretados.

7 Asegúrese de disponer el ajustador.

Un ajustador ha sido instalado debajo de la caja de pedales (C) para dar estabilidad a la misma. Gire el ajustador hasta que quede en firme contacto con la superficie del piso. El ajustador asegura una estable operación de los pedales y facilita el control del efecto de los mismos.

* Si el ajustador no está en firme contacto con la superficie del piso, se puede producir distorsión del sonido.

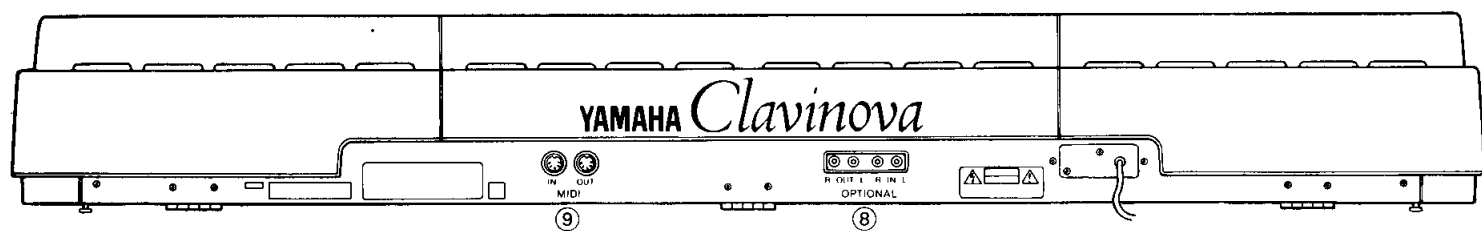
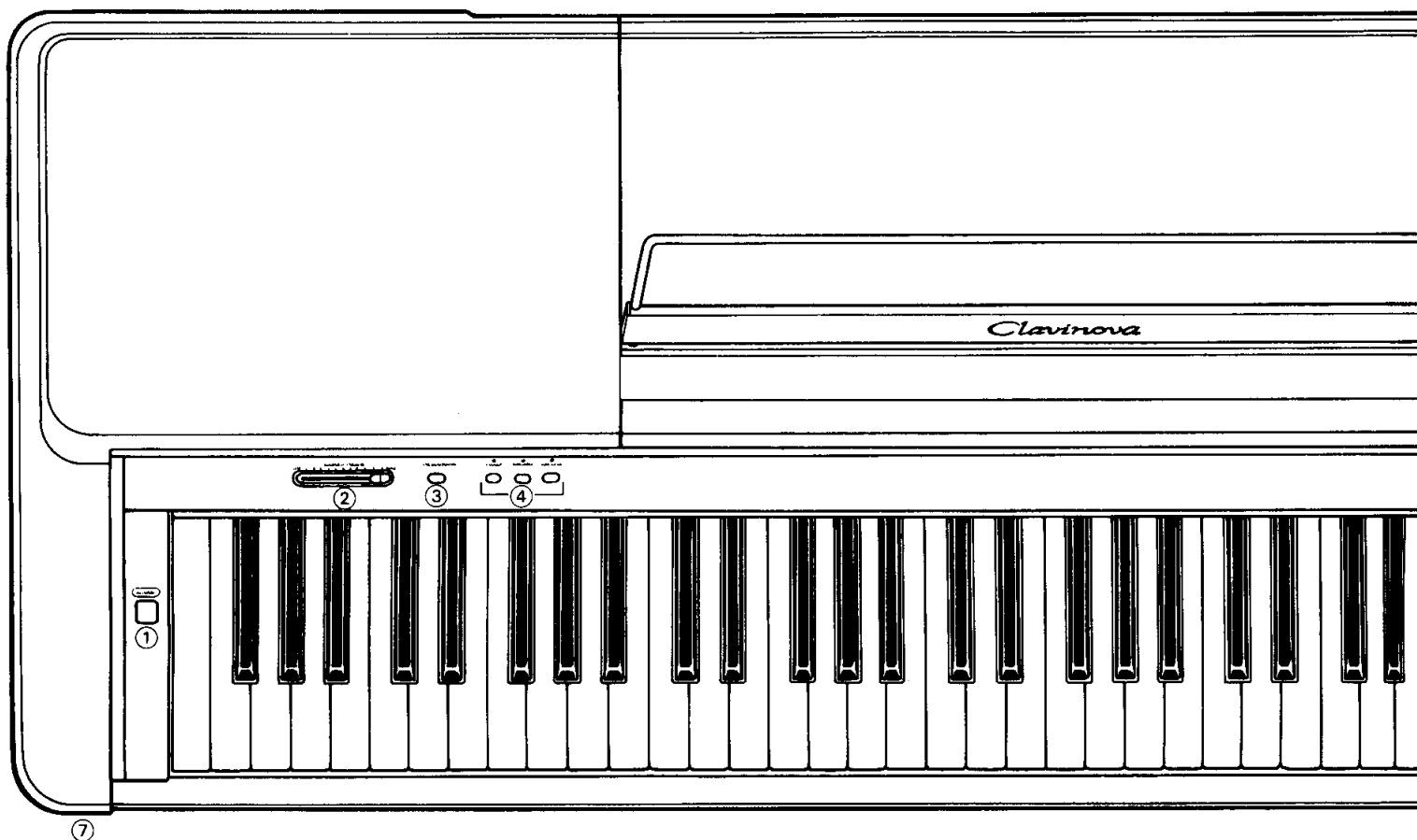

TAKING CARE OF YOUR CLAVINOVA

Your Clavinova is a fine musical instrument, and deserves the most careful treatment. Observe the following points and your Clavinova will sound and look great for many years.

1. Never open the case and touch or tamper with the internal circuitry.
2. Always turn the POWER switch OFF after use, and cover the instrument with the dust cover provided.
3. Clean the cabinet and keys of your Clavinova only with a clean, slightly damp cloth. A neutral cleanser may be used if desired. Never use abrasive cleansers, waxes, solvents or chemical dust cloths since these can dull or damage the finish.
4. Never place any vinyl products on your Clavinova. Contact with vinyl can cause irreversable damage to the finish.
5. Install your Clavinova in a place that is away from direct sunlight, excessive humidity or heat.
6. Never apply excessive force to the controls, connectors or other parts of your Clavinova, and avoid scratching or bumping it with hard objects.

THE CONTROLS AND CONNECTORS

- ① **POWER Switch**
Press the POWER switch once to turn the power ON, a second time to turn the power OFF. When the power is initially turned ON, the PIANO voice selector LED will light.
- ② **VOLUME Control**
The VOLUME control adjusts the volume (level) of sound produced by the Clavinova. The VOLUME control also adjusts headphone volume when a pair of headphones is plugged into the HEADPHONE jack ⑦.
- ③ **TRANSPOSER/MIDI Button**
The TRANSPOSER/MIDI button allows access to the Clavinova's TRANSPOSE function (to shift the pitch of the entire keyboard up or down) and MIDI functions. For details refer to the "TRANSPOSITION" and "MIDI FUNCTIONS" sections on page 8.
- ④ **Voice Selectors**
The CLP-250 has three voice selectors. Simply press one of the voice selectors to select the corresponding voice. The LED indicator above the voice selector will light to indicate which voice is currently selected.
Note: The PIANO voice is automatically selected whenever the POWER switch is initially turned ON.

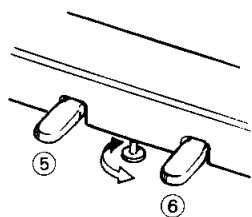
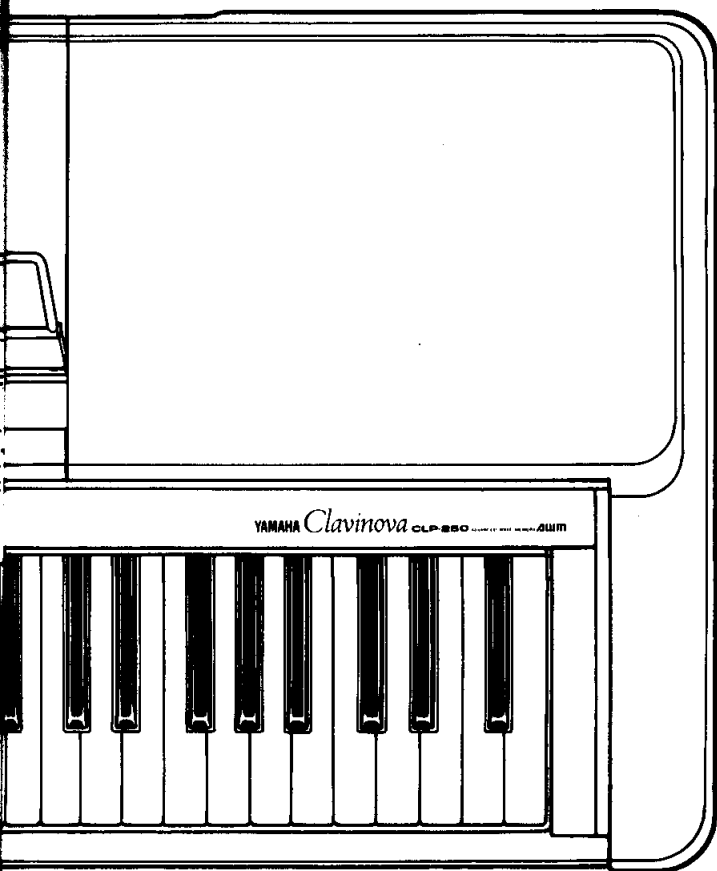

⑤ Soft/Sostenuto Pedal

This pedal has two distinct modes—"soft" and "sostenuto"—which can be selected as required.

The Soft Mode

This is the normal mode for the Soft/Sostenuto pedal, and is automatically selected when the power is initially turned ON.

In this mode, pressing the pedal reduces the volume of notes played.

The Sostenuto Mode

From the normal Soft mode, the Sostenuto mode can be selected by holding down the TRANSPOSER/MIDI button ③ and pressing the Soft/Sostenuto pedal once.

In the sostenuto mode, if you play a note or chord on the keyboard and press the pedal while the note(s) are held, those notes will be sustained as long as the pedal is held (as if the damper pedal had been pressed) but all subsequently played notes will not be sustained. This makes it possible to sustain a chord, for example, while other notes are played "staccato."

From the Sostenuto mode it is possible to return to the Soft pedal mode by holding down the TRANSPOSER/MIDI button and pressing the Soft/Sostenuto pedal.

⑥ Damper Pedal

The damper pedal functions in the same way as a damper pedal on an acoustic piano. When the damper pedal is pressed notes played have a long sustain. Releasing the pedal immediately stops (damps) any sustained notes.

Note: The damper pedal can also be used to activate an "extra sustain" mode for notes played normally (i.e. damper pedal not pressed). Hold down the TRANSPOSER/MIDI button and press/release the damper pedal, then release the TRANSPOSER/MIDI button. Notes played normally will now have slightly longer sustain. The "extra sustain" can be turned OFF by holding the TRANSPOSER/MIDI button and pressing/releasing the damper pedal again.

⑦ HEADPHONE Jack

A standard pair of stereo headphones can be plugged in here for private practice or late-night playing. The internal speaker system is automatically shut off when a pair of headphones is plugged into the HEADPHONE jack.

⑧ OPTIONAL IN L/R and OUT L/R Jacks

These jacks are intended primarily for use with Yamaha EM-series expander modules such as the EME-1 Reverb Box, EMT-1 FM Sound Box, EMT-10 AWM Sound Box and EMR-1 Drum Box. In the case of the EME-1 Reverb Box, for example, the OPTIONAL OUT jacks connect to the EME-1 LINE IN jacks, and the EME-1 LINE OUT jacks connect back to the Clavinova OPTIONAL IN jacks. This allows application of a range of high-quality digital effects, including reverb and echo, to the Clavinova sound. Refer to the EM-series owner's manual for connection details.

The OPTIONAL OUT jacks can also be used to connect the Clavinova to an external stereo sound system.

⑨ MIDI IN and OUT Connectors

The MIDI IN connector receives MIDI data from an external MIDI device (such as the EMQ-1 Memory Box) which can be used to control the Clavinova. The MIDI OUT connector transmits MIDI data generated by the Clavinova (e.g. note and velocity data produced by playing the Clavinova keyboard).

More details on MIDI are given in "MIDI FUNCTIONS" on page 8.

PREPARATION

• Check your power supply

Make sure that your local AC mains voltage matches the voltage specified on the name plate on the rear panel. In some areas a voltage selector may be provided on the rear panel of the main unit. Make sure that the voltage selector is set for the voltage in your area.

• The music stand

If you will be using sheet music with your Clavinova, insert the music stand into the holes provided on the CLP-250 top panel.

• Name Plate Location

The nameplate is located on the rear panel.

PLAYING THE CLAVINOVA

After making sure that the Clavinova's AC plug is properly inserted into a convenient AC wall outlet:

1. Press the POWER switch located to the left of the keyboard to turn the power ON. When the power is turned ON, the PIANO voice selector LED will light (the PIANO voice is automatically selected whenever the power is turned ON).



- Initially set the VOLUME control about three quarters of the way towards the "MAX" setting. Then, when you start playing, adjust the VOLUME control for the most comfortable listening level.

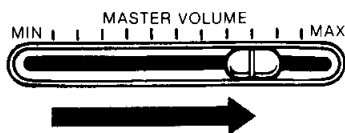

- Select the desired voice by pressing one of the voice selectors.



- Play.
The Clavinova has "8-note polyphony," which means you play up to 8 notes at once. The Clavinova also offers keyboard touch response, so the volume of notes played can be controlled according to how "hard" you play the keys. The amount of variation available depends on the selected voice.

TRANSPOSITION

The Clavinova's TRANSPOSER function makes it possible to shift the pitch of the entire keyboard up or down in semitone intervals up to a maximum of six semitones. "Transposing" the pitch of the Clavinova keyboard makes it easier to play in difficult key signatures, and you can simply match the pitch of the keyboard to the range of a singer or other instrumentalist. The TRANSPOSER/MIDI button and keys F#5 through F#6 on the keyboard are used for transposition.



- Press and hold the TRANSPOSER/MIDI button.
- Press a key between F#5 and F#6 according to the desired amount of transposition.*
- Release the TRANSPOSER/MIDI button.

* Pressing the C6 key produces normal keyboard pitch. Pressing the key to the left of C6 (B5) transposes the pitch of the keyboard down a semitone, the next key to the left (Bb5) transposes down a whole tone (two semitones), etc., down to the F#5 key which transposes down 6 semitones. Upward transposition is accomplished in the same way using the keys to the right of C6, up to F#6 which transposes up 6 semitones.

Note: The transpose function has no effect when LOCAL OFF is active (see "MIDI FUNCTIONS" on this page).

PITCH CONTROL

Pitch control makes it possible to tune the Clavinova over a ± 50 -cent range in approximately 3-cent intervals. A hundred "cents" equals one semitone, so the tuning range provided allows fine tuning of overall pitch over a range of approximately a semitone. Pitch control is useful for tuning the Clavinova to match other instruments or recorded music.

Tuning Up

- To tune up (raise pitch), hold the E0 and F0 keys simultaneously.
- Press any key between C3 and B3. Each time a key in this range is pressed the pitch is increased by approximately 3 cents, up to a maximum of 50 cents above standard pitch.
- Release the E0 and F0 keys.

Tuning Down

- To tune down (lower pitch), hold the E0 and F#0 keys simultaneously.
- Press any key between C3 and B3. Each time a key in this range is pressed the pitch is decreased by approximately 3 cents, up to a maximum of 50 cents below standard pitch.
- Release the E0 and F#0 keys.

Note: Standard pitch (A3=440 Hz) is automatically set whenever the POWER switch is initially turned ON.

MIDI FUNCTIONS

A Brief Introduction to MIDI

MIDI, the Musical Instrument Digital Interface, is a world-standard communication interface that allows MIDI-compatible musical instruments and equipment to share musical information and control one another. This makes it possible to create "systems" of MIDI instruments and equipment that offer far greater versatility and control than is available with isolated instruments. For example, most MIDI keyboards (including the Clavinova, of course) transmit note and velocity (touch response) information via the MIDI OUT connector whenever a note is played on the keyboard. If the MIDI OUT connector is connected to the MIDI IN connector of a second keyboard (synthesizer, etc.) or a tone generator such as the Yamaha EMT-1 FM Sound Box (essentially a synthesizer with no keyboard), the second keyboard or tone generator will respond precisely to notes played on the original transmitting keyboard. The result is that you can effectively play two instruments at once, providing thick multi-instrument sounds.

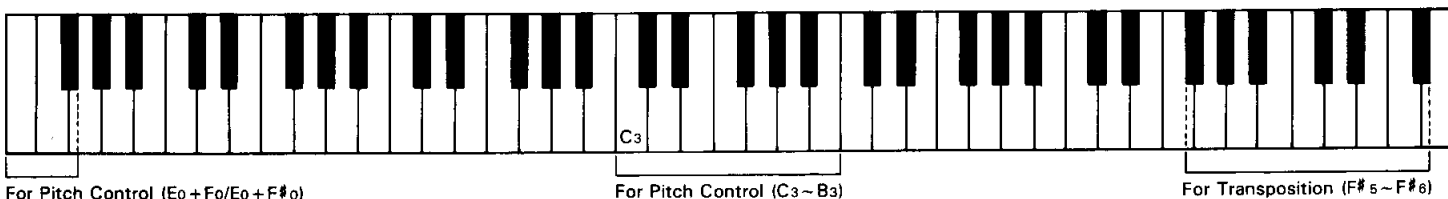
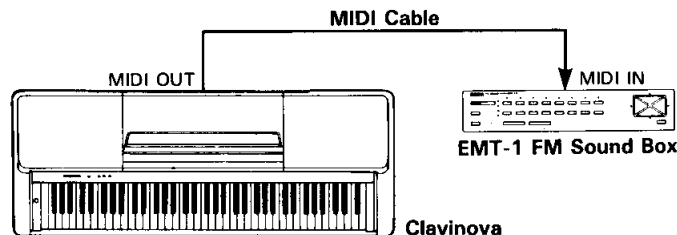

This same type of musical information transfer is used for MIDI sequence recording. A sequence recorder such as the Yamaha EMQ-1 Memory Box can be used to "record" MIDI data received from a Clavinova, for example. When the recorded data is played back, the Clavinova automatically "plays" the recorded performance in precise detail.

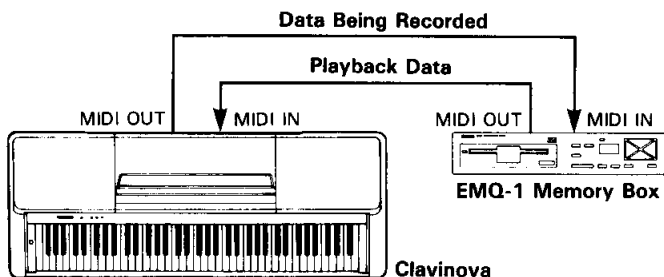

The examples given above really only scratch the surface. MIDI can do much, much more. The CLP-250 offers a number of MIDI functions that allow it to be used in fairly sophisticated MIDI systems.

Note: Always use a high-quality MIDI cable to connect MIDI OUT to MIDI IN terminals. Never use MIDI cables longer than about 15 feet, since cables longer than this can pick up noise which can cause data errors.

MIDI "Messages" Transmitted & Received by the Clavinova

The MIDI information (messages) transmitted and received by the CLP-250 Clavinova are as follows:

Note and Velocity Data

This information tells the receiving keyboard or tone generator to play a certain note (specified by the MIDI note number) at a certain dynamic level (specified by the MIDI velocity value). Note and velocity data is transmitted by the Clavinova whenever a key is pressed, and the Clavinova's internal AWM tone generator will "play" the corresponding note(s) whenever note and velocity data is received from an external MIDI device.

Program Change Numbers

The Clavinova transmits a MIDI program number between 0 and 2 when one of its voice selectors is pressed. This normally causes the correspondingly numbered voice or program to be selected on a receiving MIDI device. The Clavinova will respond in the same way, automatically selecting the appropriate voice when a MIDI program change number is received. See "Program Change ON/OFF" on page 10 for information on turning program change number reception and transmission ON or OFF.

Control Change Numbers

Control Change data representing Soft/Sostenuto and Damper pedal operations is transmitted by the Clavinova whenever one of these pedals is used. If the receiving device is a tone generator or another keyboard, it will respond in the same way as the Clavinova's internal tone generator when one of the pedals is used. The Clavinova also receives and responds to the appropriate control change data. See "Control Change ON/OFF" on page 10 for information on turning control change number reception and transmission ON or OFF.

MIDI Transmit & Receive Channel Selection

The MIDI system allows transmission and reception of MIDI data on 16 different channels. Multiple channels have been implemented to allow selective control of certain instruments or devices connected in series. For example, a single MIDI sequence recorder could be used to "play" two different instruments or tone generators. One of the instruments or tone generators could be set to receive only on channel 1, while the other is set to receive on channel 2. In this situation the first instrument or tone generator will respond only to channel-1 information transmitted by the sequence recorder, while the second instrument or tone generator will respond only to channel-2 information. This allows the sequence recorder to "play" two completely different parts on the receiving instruments or tone generators.

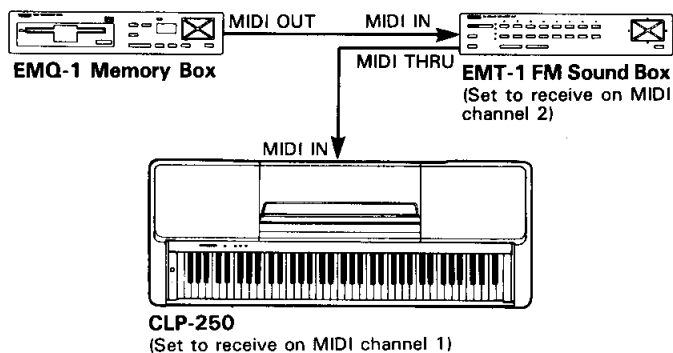

In any MIDI control setup, the MIDI channels of the transmitting and receiving equipment must be matched for proper data transfer. An "OMNI" receive mode is also available, which allows reception on all 16 MIDI channels. In the OMNI mode it is not necessary to match the receive channel of the receiving device to the transmit channel of the transmitting device (except when receiving mode messages).

Setting the Clavinova MIDI Channels

1. Press and hold the TRANSPOSER/MIDI button.
2. Press the key on the keyboard corresponding to the desired MIDI transmit or receive channel.*
3. Release the TRANSPOSER/MIDI button.

* Keys C1 through D#2 on the keyboard are used to set the MIDI transmit channel, and keys C3 through D#4 are used to turn the OMNI mode OFF and set the MIDI receive channel as shown in the illustration below. The E4 key sets the OMNI receive mode and basic receive channel 1.

Note: When the power is initially turned ON, MIDI receive is set to the OMNI mode and the transmit channel is set to 1.

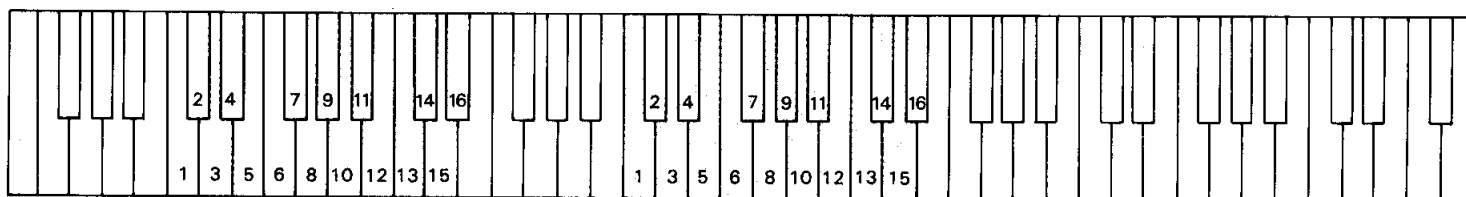

For setting the sending channel. (C1 ~ D#2)

For setting the receiving channel. (C3 ~ D#4)

MIDI FUNCTION CHART

Function	CLP-250 Voice Selector*
Local ON/OFF	PIANO
Program Change ON/OFF	E.PIANO
Control Change ON/OFF	HARPSICHORD

* The MIDI functions listed above are engaged by holding down the TRANSPOSER/MIDI button and pressing the corresponding voice selector. Full details are given below.

Local Control ON/OFF

“Local Control” refers to the fact that, normally, the Clavinova keyboard controls its internal tone generator, allowing the internal voices to be played directly from the keyboard. This situation is “Local Control ON” since the internal tone generator is controlled locally by its own keyboard.

Local control can be turned OFF, however, so that the Clavinova keyboard does not play the internal voices, but the appropriate MIDI information is still transmitted via the MIDI OUT connector when notes are played on the keyboard. At the same time, the internal tone generator responds to MIDI information received via the MIDI IN connector. This means that while an external MIDI sequence recorder such as the Yamaha EMQ-1 Memory Box, for example, plays the Clavinova’s internal voices, an external tone generator such as the EMT-1 can be played from the Clavinova keyboard.

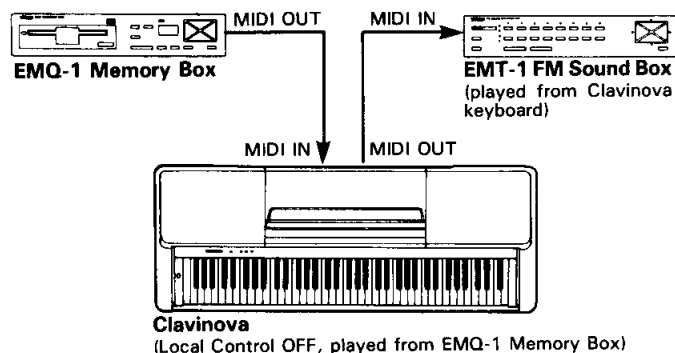

Turning Local Control ON or OFF

1. Hold down the TRANSPOSER/MIDI button.
2. Press the PIANO voice selector. If the PIANO LED is lit when the PIANO voice selector is pressed, you have turned local control OFF. If the PIANO LED is not lit when the PIANO voice selector is pressed, you have turned local control ON.
3. Release the TRANSPOSER/MIDI button.

Program Change ON/OFF

Normally the Clavinova will respond to MIDI program change numbers received from an external keyboard or other MIDI device, causing the correspondingly numbered Clavinova voice to be selected. The Clavinova will normally also send a MIDI program change number whenever one of its voices is selected, causing the correspondingly numbered voice or program to be selected on the external MIDI device if the device is set up to receive and respond to MIDI program change numbers. This function makes it possible to cancel program change number reception and transmission so that voices can be selected on the Clavinova without affecting the external MIDI device, and vice versa.

1. Hold down the TRANSPOSER/MIDI button.
2. Press the E.PIANO voice selector. If the E.PIANO LED is lit when the E.PIANO voice selector is pressed, you have turned program change reception/transmission OFF. If the E.PIANO LED is not lit when the E.PIANO voice selector is pressed, you have turned program change reception/transmission ON.
3. Release the TRANSPOSER/MIDI button.

Control Change ON/OFF

Normally the Clavinova will respond to MIDI control change data received from an external MIDI device or keyboard, causing the selected Clavinova voice to be affected by pedal and other “control” settings received from the controlling device. The Clavinova also transmits MIDI control change information when either of its pedals are operated.

This function makes it possible to cancel control change data reception and transmission if you do not want the Clavinova voices to be affected by control change data received from an external device or vice versa.

1. Hold down the TRANSPOSER/MIDI button.
2. Press the HARPSICHORD voice selector. If the HARPSICHORD LED is lit when the HARPSICHORD voice selector is pressed, you have turned control change reception/transmission OFF. If the HARPSICHORD LED is not lit when the HARPSICHORD voice selector is pressed, you have turned control change reception/transmission ON.
3. Release the TRANSPOSER/MIDI button.

TROUBLESHOOTING

If you encounter what appears to be a malfunction, please check the following points before assuming that your Clavinova is faulty.

1. No Sound When the Power is Turned ON

Is the AC plug properly connected to an AC wall outlet? Check the AC connection carefully. Is the VOLUME control turned up to a reasonable listening level?

2. The Clavinova Reproduces Radio or TV Sound

This can occur if there is a high-power transmitter in your vicinity. Contact your Yamaha dealer.

3. Intermittent Static Noise

This is usually due to turning ON or OFF a household appliance or other electronic equipment which is fed by the same AC mains line as your Clavinova.

4. Interference Appears On Radio or TV Sets Located Near the Clavinova

The Clavinova contains digital circuitry which can generate radio-frequency noise. The solution is to move the Clavinova further away from the affected equipment, or vice versa.

5. Distorted Sound When the Clavinova is Connected to An External Amplifier/Speaker System

If the Clavinova is connected to a stereo system or instrument amplifier and the sound is distorted, reduce the setting of the Clavinova volume control to a level at which the distortion ceases.

OPTIONS & EXPANDER MODULES

OPTIONS

BC-7 Bench

A stable, comfortable bench styled to match your Yamaha Clavinova.

HPE-5 Stereo Headphones

High-performance lightweight dynamic headphones with extra-soft ear pads.

PCS-3 Connecting Cord

For connecting the Clavinova to a stereo system or other audio equipment.

KC-761 Key Cover

A convenient way to keep your keyboard clean and dust-free.

EXPANDER MODULES

Sound Box EMT-10..... AWM Sound Expander

Sound Box EMT-1..... FM Sound Expander

Memory Box EMQ-1..... Disk Recorder

Drum Box EMR-1..... Digital Drums

Reverb Box EME-1..... Digital Reverb

These state-of-the-art Expander Modules can dramatically expand the musical scope of your Clavinova.

* Some items may not be available in certain areas.

MIDI DATA FORMAT

If you're already very familiar with MIDI, or are using a computer to control your music hardware with computer-generated MIDI messages, the data provided in this section can help you to control the Clavinova.

1. NOTE ON/OFF

Data format: [9 × H] → [kk] → [vv]

9 × H = Note ON/OFF event (x = channel number)

kk = Note number (Receive: 21 ~ 108 = A-1 ~ C7)

(Transmit: 28 ~ 103 = E0 ~ G6)

vv = Velocity (Key ON = 1 ~ 127. Key OFF = 0)

* Note OFF event format [8 × H] → [kk] → [vv] also recognized. (vv = 0 ~ 127).

2. CONTROL CHANGE & MODE MESSAGES

Data format: [B × H] → [cc] → [dd]

B × H = Control event (x = channel number)

cc = Control number (or mode message number)

dd = Control value

cc	PARAMETER	dd
40H	Damper pedal	0 ~ 3FH = OFF; 40H ~ 7FH = ON
42H	Sostenuto pedal	0 ~ 3FH = OFF; 40H ~ 7FH = ON
43H	Soft pedal	0 ~ 3FH = OFF; 40H ~ 7FH = ON
7AH	Local ON/OFF	0 = OFF; 7FH = ON
7BH	All notes OFF	0
7CH	OMNI OFF/All notes OFF	0
7DH	OMNI ON/All notes OFF	0

* 7AH, 7BH, 7CH and 7DH are receive only.

3. PROGRAM CHANGE

Data format: [C × H] → [dd]

C × H = program event (x = channel number)

dd = Program number

dd	VOICE
00H	PIANO
01H	E.PIANO
02H	HARPSICHORD

* No voice change is made when dd > 02H.

4. SYSTEM REALTIME MESSAGES

Active Sensing (FEH)

Transmitted every 200 milliseconds. If not received for more than 400 milliseconds a NOTE OFF occurs.

* All MIDI data available for general use are given above.

SPECIFICATIONS
TECHNISCHE DATEN
SPÉCIFICATIONS
ESPECIFICACIONES

- * Specifications subject to change without notice.
- * Änderungen ohne Vorankündigung vorbehalten.
- * Sous toute réserve de modification des caractéristiques sans préavis.
- * Especificaciones sujetas a cambio sin previo aviso.

	CLP-250
KEYBOARD	76 KEYS (E0 ~ G6)
VOICE SELECTORS	PIANO, E.PIANO, HARPSICHORD
PEDAL CONTROLS	DAMPER (2 modes), SOFT, SOSTENUTO
OTHER CONTROLS	MASTER VOLUME, TRANSPOSER/MIDI
JACKS/CONNECTORS	HEADPHONES, OPTIONAL IN L/R, OPTIONAL OUT L/R, MIDI IN/OUT, PEDAL
INPUT & OUTPUT LEVEL/IMPEDANCE	OPTIONAL OUT: 600 Ω/1 ~ 4 Vpp OPTIONAL IN: 22 kΩ/ - 10 dBm (for nominal output level)
MAIN AMPLIFIER	20 W × 1
SPEAKERS	16 cm (6 2/7") × 2
DIMENSIONS	1253 × 467 × 804 mm
WEIGHT	38 kg (83.8 lbs.)

[Clavinova]
 Model CLP-250 MIDI Implementation Chart

Date : 6/16, 1988
 Version : 1.0

Function	Transmitted	Recognized	Remarks
Basic Default	1	1	
Channel Changed	1-16	1-16	
Mode Default Messages	3 X	1 OMNlon,OMNloff	
Note Number : True voice	28-103 *****	21-108 21-108	
Velocity Note on Note off	0 9nH,v=1-127 X 9nH,v=0	0 v=1-127 X	
After Key's Touch Ch's	X X	X X	
Pitch Bender	X	X	
Control Change	64 0 66 0 67 0	0 0 0	Damper Sostenuto Soft
Program Change : True #	0 0-2 *****	0 0-2 0-2	
System Exclusive	X	X	
System : Song Pos : Song Sel Common : Tune	X X X	X X X	
System : Clock Real Time: Commands	X X	X X	
Aux : Local ON/OFF : All Notes OFF Mes- : Active Sense sages: Reset	X X 0 X	0 0 (123-125) 0 X	
Notes			

Mode 1 : OMNI ON, POLY Mode 2 : OMNI ON, MONO 0 : Yes
 Mode 3 : OMNI OFF, POLY Mode 4 : OMNI OFF, MONO X : No

FCC INFORMATION (U.S.A.)

1. IMPORTANT NOTICE: DO NOT MODIFY THIS UNIT!

This product, when installed as indicated in the instructions contained in this manual, meets FCC requirements. Modifications not expressly approved by Yamaha may void your authority, granted by the FCC, to use the product.

2. IMPORTANT: When connecting this product to accessories and/or another product use only high quality shielded cables. Cable/s supplied with this product **MUST** be used. Follow all installation instructions. Failure to follow instructions could void your FCC authorization to use this product in the USA.

3. NOTE: This product has been tested and found to comply with the requirements listed in FCC Regulations, Part 15 for Class "B" digital devices. Compliance with these requirements provides a reasonable level of assurance that your use of this product in a residential environment will not result in harmful interference with other electronic devices. This equipment generates/uses radio frequencies and, if not installed and used according to the instructions found in the users manual, may cause interference harmful to the operation of other electronic devices. Compliance with FCC regulations does not guarantee that interference will not occur in all installations. If this product is found to be the source of interference, which can be determined by turning the unit "OFF" and "ON", please try to eliminate the problem by using one of the following measures:

Relocate either this product or the device that is being affected by the interference.

Utilize power outlets that are on different branch (circuit breaker or fuse) circuits or install AC line filter/s.

In the case of radio or TV interference, relocate/reorient the antenna. If the antenna lead-in is 300 ohm ribbon lead, change the lead-in to co-axial type cable.

If these corrective measures do not produce satisfactory results, please contact the local retailer authorized to distribute this type of product. If you can not locate the appropriate retailer, please contact Yamaha Corporation of America, Electronic Service Division, 6600 Orangethorpe Ave, Buena Park, CA90620

The above statements apply **ONLY** to those products distributed by Yamaha Corporation of America or its subsidiaries.

* This applies only to products distributed by YAMAHA CORPORATION OF AMERICA.

Wichtiger Hinweis für die Benutzung in der Bundesrepublik Deutschland.

Bescheinigung des Importeurs

Hiermit wird bescheinigt, daß der/die/das
Electronic Piano Typ: CLP-250

(Gerät, Typ, Bezeichnung)

in Übereinstimmung mit den Bestimmungen der
VERFÜGUNG 1046/84

(Amtsblattverfügung)

funk-entstört ist.

Der Deutschen Bundespost wurde das Inverkehrbringen dieses Gerätes angezeigt und die Berechtigung zur Überprüfung der Serie auf Einhaltung der Bestimmungen eingeräumt.

Yamaha Europa GmbH

Name des Importeurs

• Dies bezieht sich nur auf die von der Yamaha Europa GmbH vertriebenen Produkte.

CANADA

THIS DIGITAL APPARATUS DOES NOT EXCEED THE "CLASS B" LIMITS FOR RADIO NOISE EMISSIONS FROM DIGITAL APPARATUS SET OUT IN THE RADIO INTERFERENCE REGULATION OF THE CANADIAN DEPARTMENT OF COMMUNICATIONS.

LE PRESENT APPAREIL NUMERIQUE N'EMET PAS DE BRUITS RADIOELECTRIQUES DEPASSANT LES LIMITES APPLICABLES AUX APPAREILS NUMERIQUES DE LA "CLASSE B" PRESCRITES DANS LE REGLEMENT SUR LE BROUILLAGE RADIOELECTRIQUE EDICTE PAR LE MINISTERE DES COMMUNICATIONS DU CANADA.

• This applies only to products distributed by Yamaha Canada Music Ltd.

• Ceci ne s'applique qu'aux produits distribués par Yamaha Canada Musique Ltée.

IMPORTANT NOTICE FOR THE UNITED KINGDOM

Connecting the Plug and Cord

IMPORTANT. the wires in this mains lead are coloured in accordance with the following code:

BLUE : NEUTRAL
BROWN : LIVE

As the colours of the wires in the mains lead of this apparatus may not correspond with the coloured markings identifying the terminals in your plug proceed as follows:

The wire which is coloured BLUE must be connected to the terminal which is marked with the letter N or coloured BLACK.

The wire which is coloured BROWN must be connected to the terminal which is marked with the letter L or coloured RED.

• This applies only to products distributed by Yamaha-Kemble Music (U.K.) Ltd.

YAMAHA