

YAMAHA ELECTONE[®]

ME-55A / ME-35A / ME-15A

Welcome to the Musical World of YAMAHA

Willkommen in der Musikalischen Welt von YAMAHA

Bienvenue dans le Monde Musical de YAMAHA

Bienvenido al Mundo Musical de YAMAHA

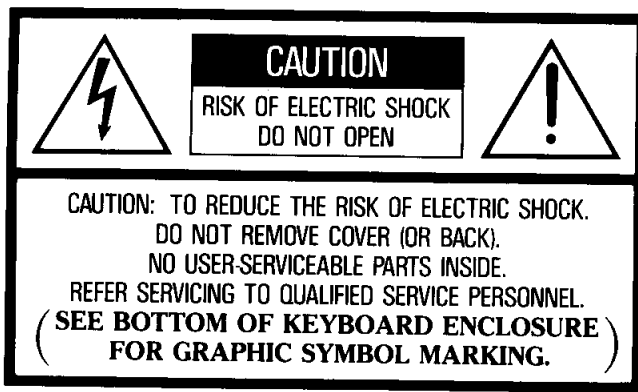

Explanation of Graphical Symbols

The lightning flash with arrowhead symbol, within an equilateral triangle, is intended to alert the user to the presence of uninsulated "dangerous voltage" within the product's enclosure that may be of sufficient magnitude to constitute a risk of electric shock to persons.

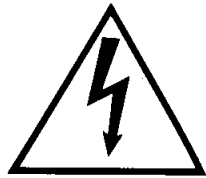

The exclamation point within an equilateral triangle is intended to alert the user to the presence of important operating and maintenance (servicing) instructions in the literature accompanying the product.



IMPORTANT SAFETY AND INSTALLATION INSTRUCTIONS

INFORMATION RELATING TO POSSIBLE PERSONAL INJURY, ELECTRIC SHOCK, AND FIRE HAZARD POSSIBILITIES HAS BEEN INCLUDED IN THIS LIST.

WARNING—When using electronic products, basic precautions should always be followed, including the following:

1. Read all Safety and Installation Instructions, Supplemental Marking and Special Message Section data, and assembly instructions (where applicable) BEFORE using your Yamaha electronic product. Check unit weight specifications before you attempt to move this instrument!
2. **Main Power Supply Verification:** Your Yamaha electronic product has been manufactured specifically for the main supply voltage used in your area. If you should move, or if any doubt exists, please contact your dealer for instructions. The main supply voltage required by your electronic product is printed on the name plate. For name plate location, see graphic in Special Message Section.
3. This product may be equipped with a polarized line plug (one blade wider than the other). If you are unable to insert the plug into the outlet, contact an electrician to have your obsolete outlet replaced. Do NOT defeat the safety purpose of the plug. Yamaha products not having polarized plugs incorporate construction methods and designs that do not require line plug polarization.
4. **WARNING**—Do NOT place objects on your electronic product's power cord or place the unit in a position where anyone could trip over, walk over, or roll anything over cords of any kind. Do NOT allow your electronic product or its bench to rest on or be installed over cords of any type. Improper installations of this type create the possibility of a fire hazard and/or personal injury.
5. **Environment:** Your electronic product should be installed away from heat sources such as a radiator, heat registers and/or other products that produce heat. Additionally, the unit should not be located in a position that exposes the cabinet to direct sunlight, or air currents having high humidity or heat levels.
6. Your Yamaha electronic product should be placed so that its location or position does not interfere with its proper ventilation.
7. Some Yamaha electronic products may have benches that are either a part of the product or supplied as an optional accessory. Some of these benches are designed to be dealer assembled. Please make sure that the bench is stable before using it. The bench supplied by Yamaha was designed for seating only. No other uses are recommended.
8. Some Yamaha electronic products can be made to operate with or without the side panels or other components that constitute a stand. These products should be used only with the components supplied or a cart or stand that is recommended by the manufacturer.
9. Do not operate for a long period of time at a high volume level or at a level that is uncomfortable. If you experience any hearing loss or ringing in the ears, you should consult an audiologist.
10. Do not use your Yamaha electronic product near water or in wet environments. For example, near a swimming pool, spa, or in a wet basement.
11. Care should be taken so that objects do not fall, and liquids are not spilled, into the enclosure through openings.
12. Your Yamaha electronic product should be serviced by a qualified service person when:
 - a. The power-supply cord or plug has been damaged: or
 - b. Objects have fallen, or liquid has been spilled into the product: or
 - c. The product has been exposed to rain: or
 - d. The product does not operate, exhibits a marked change in performance: or
 - e. The product has been dropped, or the enclosure of the product has been damaged.
13. When not in use, always turn your Yamaha electronic product "OFF". The power-supply cord of the product should be unplugged from the outlet when it is to be left unused for a long period of time. Notes: In this case, some units may lose some user programmed data. Factory programmed memories will not be affected.
14. Do not attempt to service the product beyond that described in the user-maintenance instructions. All other servicing should be referred to qualified service personnel.
15. **Electromagnetic Interference (RFI).** This series of Yamaha electronic products utilizes digital (high frequency pulse) technology that may adversely affect Radio/TV reception or the operation of other devices that utilize digital technology. Please read FCC Information (Page 27) for additional information.

**PLEASE KEEP THIS MANUAL
FOR FUTURE REFERENCE!**

CONTENTS

I. THE BASIC FEATURES

1. Now, Let's Create Some Registrations..... 2
2. Using Effects for an Even Richer Sound..... 6
3. Adding Rhythm..... 8
4. Having Fun with Automatic Accompaniment10
5. Harmonizing the Melody12
6. Memorizing Your Favorite Registrations13
7. Transferring Information to a Pack14

II. MULTI-MENU (ME-55A/ME-35A Only)

1. You Can Recall 16 Different Registrations15
2. 22 Additional Voices Can Be Transferred to the Control Panel16
3. You Can Also Memorize Vibrato and Sustain Effects....17

4. Transposing18
5. Programming the Accompaniment19
6. Transferring Information to a Cassette25

III. OTHER INFORMATION

- Accessory Jacks26
- Electromagnetic Interference.....26
- Installation and Maintenance.....27
- FCC Information (USA).....27
- Troubleshooting28
- Specifications30
- How to Use MIDI31
- Glossary for the ME Electones32
- MIDI Implementation Chart34

INHALTSVERZEICHNIS

I. DIE GRUNDLEGENDEN MERKMALE

1. Lassen Sie uns einige Registraturen erzeugen 2
2. Effekte für einen noch reicheren Klang..... 6
3. Hinzufügen von Rhythmus 8
4. Spaß mit der automatischen Begleitung10
5. Harmonisieren mit der Melodie.....12
6. Speichern der besten Registraturen13
7. Übertragen von Information zum Pack14

II. MULTI-MENU (nur ME-55A/ME-35A)

1. Sie können 16 verschiedene Registraturen abrufen....15
2. 22 zusätzliche Stimmen können zum Steuerpult übertragen werden16
3. Auch Vibrato- und Sustain-Effekte können gespeichert werden17

4. Transponieren18
5. Programmieren der Begleitung.....19
6. Übertragen der Information auf Cassette25

III. WEITERE INFORMATION

- Anschlußbuchsen für Sonderzubehör26
- Elektromagnetische Interferenzen26
- Aufstellung und Pflege.....27
- Störungsbeseitigung28
- Technische Daten30
- Verwendung von MIDI31
- Glossar für ME-Electones32
- MIDI-Anwendungstabelle.....34

TABLE DES MATIERES

I. CARACTERISTIQUES FONDAMENTALES

1. Création de quelques registres 2
2. Utilisation des effets pour un enrichissement du son 6
3. Addition d'un rythme..... 8
4. Les joies de l'accompagnement automatique.....10
5. Harmonisation de la mélodie12
6. Mémorisation des mélodies favorites13
7. Transfert d'information sur un accu mémoire14

II. MULTI-MENU (ME-55A/ME-35A uniquement)

1. Rappel de 16 registres différents.....15
2. Transfert de 22 voix supplémentaires vers le panneau de commande.....16

3. Mémorisation des effets de vibrato et de soutien17
4. Transposition18
5. Programmation de l'accompagnement.....19
6. Transfert d'information sur une cassette25

III. AUTRES INFORMATIONS

- Prises accessoires.....26
- Interférence électromagnétique26
- Installation et entretien27
- Dépannage28
- Spécifications30
- Utilisation du MIDI31
- Glossaires des Electones ME32
- Tableau d'implantation MIDI34

ÍNDICE

I. FUNCIONES BÁSICAS

1. Ahora, crearemos algunos registros..... 2
2. Utilización de efectos para lograr un sonido más rico todavía 6
3. Adición de ritmos..... 8
4. Utilización del acompañamiento automático10
5. Armonización de melodías12
6. Memorización de sus registros favoritos13
7. Transferencia de información a un cartucho14

II. MENÚ MÚLTIPLE (ME-55A y ME-35A solamente)

1. Usted puede utilizar 16 registros diferentes.....15
2. Al panel de control pueden transferirse 22 voces adicionales16

3. Usted también puede memorizar efectos de vibrato y sostenido17
4. Transposición18
5. Programación de acompañamientos.....19
6. Transferencia de información a un casete25

III. INFORMACIÓN ÚTIL

- Tomas para accesorios26
- Interferencia electromagnética26
- Instalación y mantenimiento27
- Guía para la solución de problemas28
- Especificaciones30
- Empleo de MIDI31
- Glosario para los Electones ME32
- Tabla de implementación de MIDI34

I. THE BASIC FEATURES

1. Now, Let's Create Some Registrations

UPPER KEYBOARD VOICE SECTIONS

There are two Voice sections for the upper keyboard: ORCHESTRAL VOICES and LEAD VOICES.

1 Choose one voice each from ORCHESTRAL VOICES and LEAD VOICES.

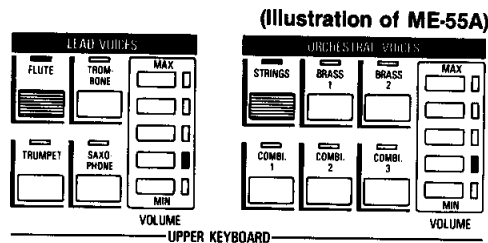

ORCHESTRAL VOICES: This voice section consists of two groups of sounds. The Orchestra group recreates the major instrumental sections of an orchestra, while the Combination group provides a variety of organ sounds.

LEAD VOICES: This section contains solo instruments such as flute, saxophone and trombone. These sounds are monophonic, which means that only one note may be played at any given time.

2 Set the volume.

Set the VOLUME to the desired level for each section. Five volume levels can be selected—the top one (MAX) being full volume and the bottom one (MIN) being OFF.

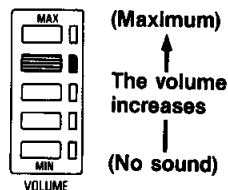

3 Play the upper keyboard.

The voices you have selected will be heard. Try choosing other voices of the UPPER ORCHESTRAL VOICES and LEAD VOICES sections and compare the sounds.

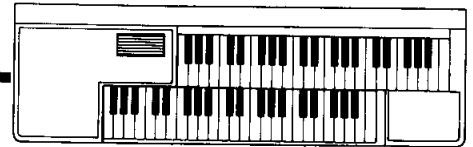

[Number of Concurrently Sounded Notes]

UPPER ORCHESTRAL VOICES: When multiple keys are pressed at the same time, up to seven notes can be played. (If AUTO BASS CHORD is in use, up to six notes can be played.)

LEAD VOICES: When multiple keys are pressed at the same time, only the highest note will be played.

[The Grey Buttons]

The UPPER ORCHESTRAL VOICES and LEAD VOICES sections are each provided with a grey button. These buttons can be used to select a voice displayed on the panel or can be assigned with a voice from the VOICE MENUS. (For ME-55A/ME-35A, see page 16; for ME-15A, see page 4.)

And when a Basic Registration is in use, these grey buttons will go ON.

[To Cancel the Sound of a Voice Section]

If you do not need the sound from a particular Voice section, set the volume level of that section to its bottom position (MIN).

LOWER KEYBOARD VOICE SECTION

There is one Voice section for the lower keyboard: ORCHESTRAL VOICES.

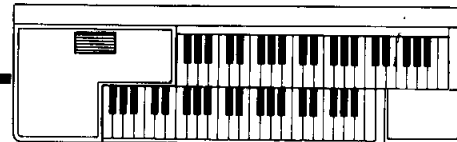

1 Choose one voice from ORCHESTRAL VOICES, then set its volume.

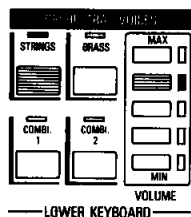

(Illustration of ME-55A/ME-35A)

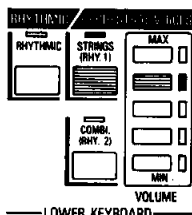

(Illustration of ME-15A)

ORCHESTRAL VOICES: This voice section consists of two groups of sounds. The Orchestra group recreates the major instrumental sections of an orchestra, while the Combination group provides a variety of organ sounds.

If you are using ME-15A, be sure to set its RHYTHMIC button to OFF.

2 Play the lower keyboard.

Your selected voice will be heard. Try choosing other voices of the LOWER ORCHESTRAL VOICES section and compare the sounds.

[Number of Concurrently Sounded Notes]
LOWER ORCHESTRAL VOICES: When multiple keys are pressed at the same time, up to seven notes can be played. (If AUTO BASS CHORD is in use, up to four notes can be played.)

[The Grey Buttons]

The LOWER ORCHESTRAL VOICES section is provided with a grey button, which can be used to select a voice displayed on the panel or assigned with a voice from the VOICE MENUS. (For ME-55A/ME-35A, see page 16; for ME-15A, see page 4.)

And when a Basic Registration is in use, the grey button will go ON.

[The RHYTHMIC Feature of ME-15A]

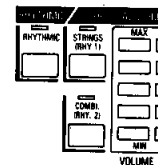

If this button is pressed to ON while Auto Rhythm is in use, the selected voice will change to be synchronized with the rhythm. (See page 5.)

PEDAL KEYBOARD VOICE SECTION

There is one Voice section for the pedal keyboard: BASS VOICES.

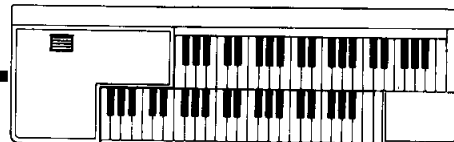

1 Choose one voice from BASS VOICES, then set its volume.

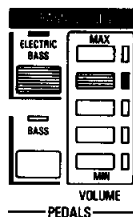

BASS VOICES: This section consists of the sounds of the electric bass and traditional organ bass. In order to hear your pedal sounds, please be sure that "Single Finger" and "Fingered Chord" (Auto Bass Chord section) are "Off".

2 Play the pedal keyboard.

Your selected voice will be heard. Try choosing the other BASS voice and compare the sounds.

[Number of Concurrently Sounded Notes]
BASS VOICES: When multiple keys are pressed at the same time, only the highest note will be sounded.

[The Grey Buttons]

The BASS VOICES section is provided with a grey button, which can be used to select a voice displayed on the panel or assigned with a voice from the VOICE MENUS. (For ME-55A/ME-35A, see page 16; For ME-15A, see page 4.)

Moreover, when a Basic Registration is in use, the grey button will go ON.

[While AUTO BASS CHORD is in Use]

While the SINGLE FINGER or FINGERED CHORD mode of AUTO BASS CHORD is ON, notes of the pedal keyboard will automatically be sounded by merely playing the lower keyboard. (See pages 10-11.)

In addition, the AUTO BASS CHORD feature is designed so that, while SINGLE FINGER or FINGERED CHORD is ON, any keys pressed on the pedal keyboard will not be sounded.

VOICE MENU (ME-15A)

The ME-15A has seven additional voices which can be used by transferring them to any grey buttons in any VOICE section.

1 Determine which voice to transfer and which section you wish to transfer that voice to.

The voices on the VOICE MENU can be transferred to any of the grey buttons in the VOICES sections.

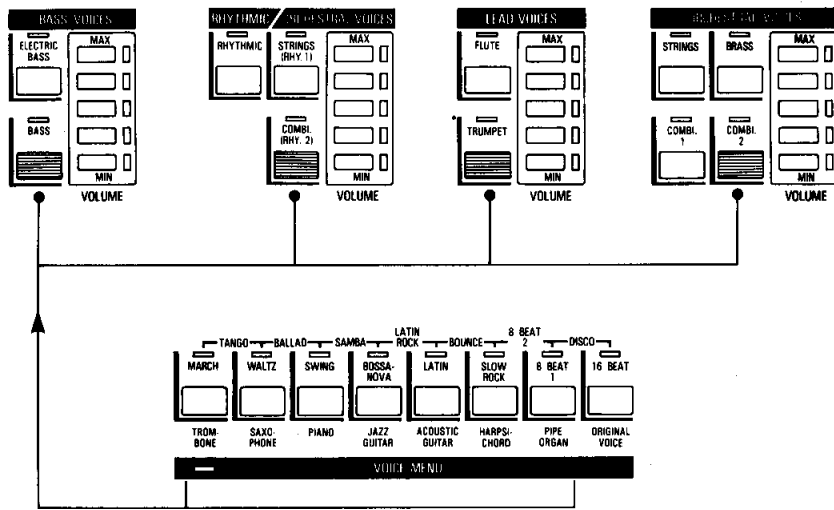

2 While depressing the grey button in the VOICE section where you wish to transfer the sound, press the button of the voice to be transferred.

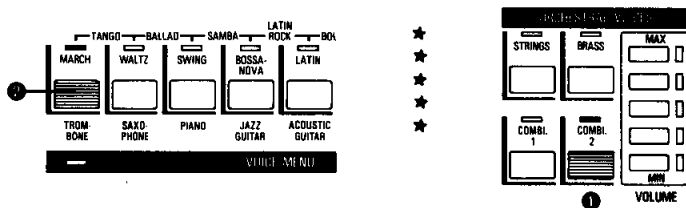

When a grey button is pressed, the lamp in the VOICE MENU lights up, enabling the eight (rhythm) buttons to function as the VOICE MENU. (They normally function as the pattern selectors for Auto Rhythm.) While this lamp is lit, press one of the seven buttons from TROMBONE to PIPE ORGAN. The lamp of the grey button in the VOICE section you transferred it to flashes to indicate that the sound has been transferred. Please try transferring other voices using this same procedure. Note that if the POWER switch is turned off, the voices transferred to the grey buttons will be returned to their Original Voices (the voices as displayed).

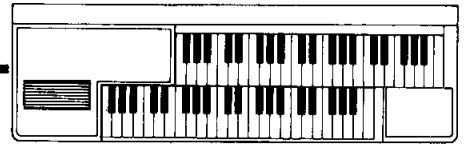

[Checking the Transferred Voices]

When a grey button is pressed, the lamp of the voice transferred to that button will light up, indicating which voice was transferred.

If no voices from the VOICE MENU have been transferred to that location, the ORIGINAL VOICE lamp lights up.

[ORIGINAL VOICE]

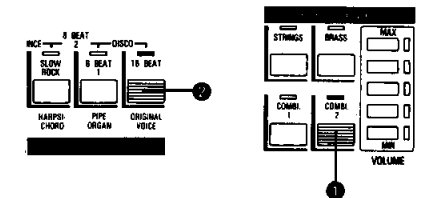

When the ORIGINAL VOICE button is pressed while depressing the grey button, you can cancel the sound transferred to that button and return to its displayed voice.

[Additional Information]

- The same voice can be transferred to multiple grey buttons.
- When a VOICE MENU sound has been transferred to LEAD or BASS VOICES, they automatically become "monophonic" voices, meaning that only one note at a time can be played.

ARPEGGIO CHORD/RHYTHMIC

By merely pressing chords on the lower keyboard, you can produce an automatic accompaniment that is synchronized with the rhythm.

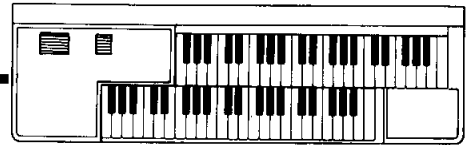

ARPEGGIO CHORD [ME-55A/ME-35A]

1 Choose one of the four patterns, then set its volume.

1 or 2: Produces a rhythmic chord strumming accompaniment pattern in time with the rhythm.

3 or 4: Produces a melodious arpeggio pattern in time with the rhythm.

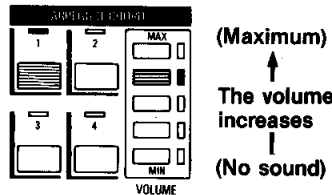

[The Patterns and Voices of ARPEGGIO CHORD and RHYTHMIC]

Your Electone is designed to produce the ARPEGGIO CHORD or RHYTHMIC pattern and voice that is best suited to each rhythm pattern.

[Be Sure to Use these Features with AUTO RHYTHM!]

The ARPEGGIO CHORD feature of ME-55A/ME-35A and the RHYTHMIC feature of ME-15A are synchronized with, and controlled by, the AUTO RHYTHM feature, so the rhythm must be "ON" for them to operate.

2 Press the SYNCHRO START switch.
(See page 8.)

You may also start the rhythm by pressing the START switch instead of SYNCHRO START.

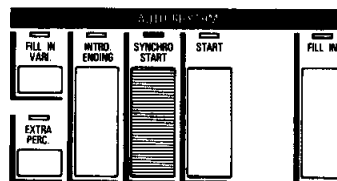

[When Used in Combination with AUTO BASS CHORD]

The use of ARPEGGIO CHORD or RHYTHMIC in combination with AUTO BASS CHORD will simplify the creation of an accompaniment that is synchronized with the rhythm. And when the MEMORY button of AUTO BASS CHORD is set to ON, the ARPEGGIO CHORD or RHYTHMIC notes will continue sounding even after you have released the keys of the lower keyboard. (See pages 10-11.)

3 Press a chord on the lower keyboard.

As long as you hold down the chord, an accompaniment pattern will be automatically sounded in time with the rhythm.

[The Relationship between ARPEGGIO CHORD and Bass Patterns]

If an ARPEGGIO CHORD pattern is being used in combination with AUTO BASS CHORD, a change in the ARPEGGIO CHORD pattern will also cause the Bass pattern to be changed. (ME-55A/ME-35A only)

RHYTHMIC [ME-15A]

1 Press the RHYTHMIC button, then set the volume.

The RHYTHM button is capable of transforming a voice in the LOWER ORCHESTRAL VOICES section into a voice that is sounded in time with the rhythm.

Press the RHYTHMIC button to ON, then select one of the two LOWER ORCHESTRAL voices.

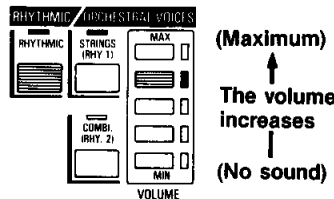

[If the ARPEGGIO CHORD Sound is not Needed]

When you wish to play the lower keyboard accompaniment using only the sounds of ORCHESTRAL VOICES, set the volume of the ARPEGGIO CHORD section to OFF (MIN).

2 Press the SYNCHRO START switch. (See page 8.)

You may also start the rhythm by pressing the START switch instead of SYNCHRO START.

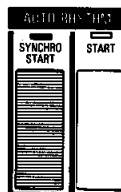

3 Press a chord on the lower keyboard.

As long as you hold down the chord, an accompaniment pattern will be automatically sounded in time with the rhythm.

2. Using Effects for an Even Richer Sound

SUSTAIN

You can add an aftersound to notes so that they will be sustained even after their keys have been released.

1 Set a voice for each keyboard. (See pages 2-3.)

Select one voice from ORCHESTRAL VOICES for the upper and lower keyboards, and one from BASS VOICES for the pedal keyboard.

NOTE: The Sustain effect cannot be added to LEAD VOICES of the upper keyboard.

2 Set the SUSTAIN buttons to ON.

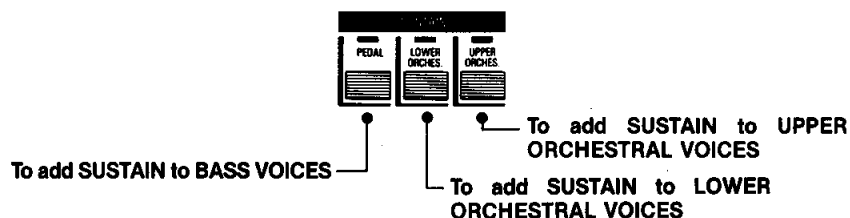

NOTE: With ME-55A/ME-35A, the SUSTAIN length can be set using the Multi Menu. (See page 18.)

3 Play notes on each of the keyboards.

After releasing your hands (or foot) from the keys, a gradually fading aftersound is added to each note.

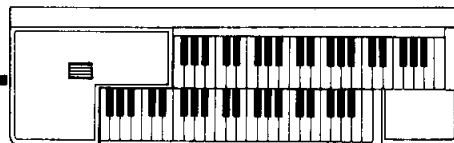

[The SUSTAIN Length]

ME-15A: Aftersounds of the most suitable length are preset for the notes of each keyboard.

ME-55A/ME-35A: The length of the aftersounds can be set for each keyboard using the Multi-Menu. (See Page 18)

Note that the Sustain effect will become invalid if the SUSTAIN length on the Multi Menu is set to zero.

USER VIBRATO (ME-55A/ME-35A)

A Vibrato effect which finely vibrates the notes can also be produced.

1 Set an upper keyboard voice. (See page 2.)

2 Set the appropriate USER VIBRATO button to ON then play the upper keyboard.

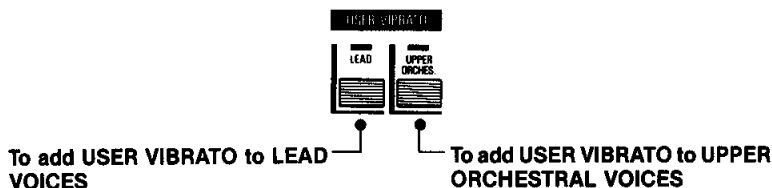

When the upper keyboard is played, the notes will be sounded with the User Vibrato effect added. The degree of vibration for User Vibrato is set using the Multi-Menu. (See Page 17)

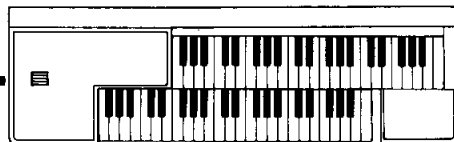

[Preset Vibrato]

For the voices of the upper and lower keyboards, the VOICE MENU voices, and the Basic Registration voices, the most suitable Vibrato effect has been preset for each voice.

[The Relationship between Preset Vibrato and User Vibrato]

With ME-55A/ME-35A, by setting the USER VIBRATO button to ON, a Vibrato effect that you have set yourself can be added in place of the Preset Vibrato effect. User Vibrato can be added to LEAD VOICES and ORCHESTRAL VOICES of the upper keyboard.

TREMOLO/SYMPHONIC

(ME-55A only)

These effects add another dimension to the Upper and Lower ORCHESTRAL VOICES sections.

1 Choose one sound from the ORCHESTRAL VOICES section of the upper keyboard, and one sound from the corresponding section for the lower keyboard. Then set the volume levels.

2 Press the UPPER ORCHES. and LOWER ORCHES. buttons.

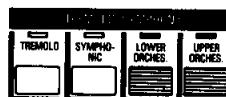

This button adds the effect to the upper keyboard.

This button adds the effect to the lower keyboard.

3 Add the TREMOLO effect. Now, play some keys on both the upper and lower keyboards.

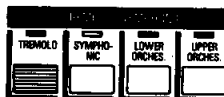

TREMOLO simulates the sound of a rotating speaker system (fast speed).

4 Add the SYMPHONIC effect. Now, play some keys on both the upper and lower keyboards.



SYMPHONIC produces an "electronic" animation that gives the impression that a large number of instruments are playing together.

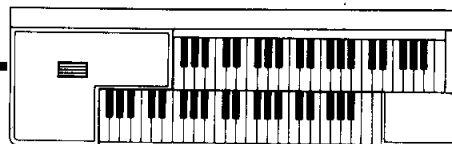

[CHORUS Effect]

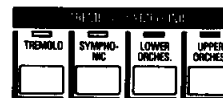

When the Tremolo and Symphonic effects are OFF, a CHORUS effect will be produced (slow tremolo).

GLIDE (ME-55A only)

This effect allows you to temporarily lower the pitch of a LEAD VOICES sound by approximately one-half step.

1 Turn both FOOT SWITCH selectors to OFF. (See page 9.)



2 Select LEAD VOICES sound, then move the Foot Switch to the left while holding some notes on the upper keyboard.

While the Foot Switch is being held to the left, the pitch of the LEAD VOICE selected (on the upper keyboard) is lowered by approximately a halfstep. When the Foot Switch is released, the pitch slowly returns to normal.

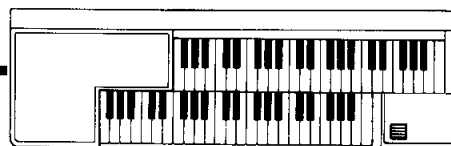
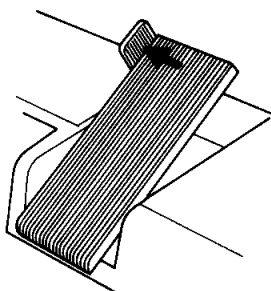

[Additional Information]

- This effect is particularly useful in the simulation of acoustic instruments that are customarily played using a glide effect... such as trombone, guitar, and violin.
- While the Glide effect is ON, the Vibrato effect applied to LEAD VOICES becomes inactive.

3. Adding Rhythm

AUTO RHYTHM

This effect automatically produces various rhythm patterns consisting of authentic percussion sounds. It also has functions, such as FILL IN and INTRO./ENDING, for varying the rhythm.

1 Select one of the rhythm patterns and set the desired volume level.

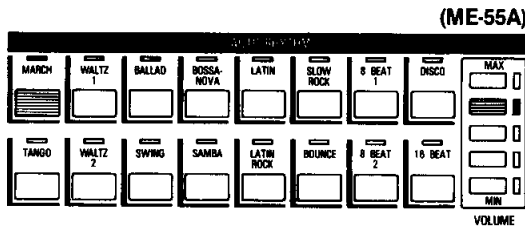

The ME-55A has 16 different rhythm patterns. Choose one pattern from among the above pattern selectors.

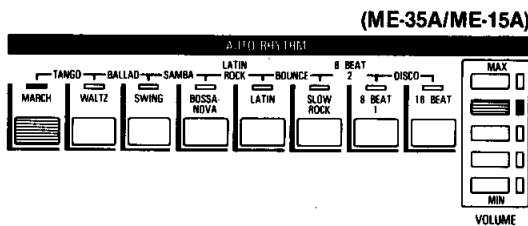

The ME-35A and ME-15A have 15 distinct rhythm patterns. To choose one of the eight patterns displayed on the bottom row (MARCH, WALTZ, SWING, etc.), press the appropriate button. To choose one of the seven patterns displayed on the top row (TANGO, BALLAD, SAMBA, etc.), simultaneously press the two adjacent buttons below the desired pattern name (both of their indicator lamps will be illuminated.) (For example, to choose TANGO, simultaneously press the MARCH and WALTZ buttons.)

2 Adjust the tempo (speed) of the rhythm.

This knob is used to control the speed of the rhythm. The tempo will increase if you turn the knob clockwise and will decrease when you turn it counter-clockwise.

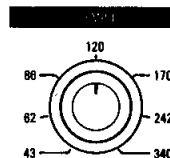

3 Turn the rhythm on.

If you turn this switch ON, the rhythm will wait and start with you when you play a note on the lower (or pedal) keyboard.

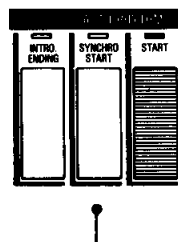

When this switch is turned ON, the rhythm will start immediately.

Once the rhythm has been started, pressing one of these switches again will stop the rhythm.

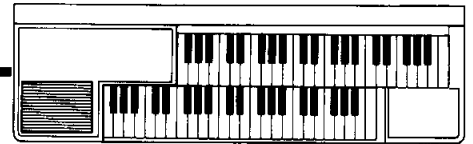

[TEMPO Lamp]



TEMPO

Once the rhythm has been activated, this lamp will flash at the first beat (downbeat) of each measure.

In addition, when SYNCHRO START is in use, this lamp will act as a silent visual metronome, indicating the exact tempo (in quarter notes) until the rhythm is started.

[Numerals on the TEMPO Knob]

Please refer to these values as a "yardstick" for setting the speed of the rhythm.

[Additional Information]

● Since Synchro Start enables the rhythm and accompaniment to be started at the same time, it is very convenient when playing accompaniment using Auto Bass Chord. (See page 10.)

FILL IN (ME-55A/ME-35A)

1 Start the rhythm.

2 Press the **FILL IN** switch when you want to add this feature.

FILL IN provides a variation to the basic rhythm pattern. At the time you press the switch, the Fill In pattern will play until the end of that measure, and the rhythm will automatically return to the original pattern at the start of the next measure.

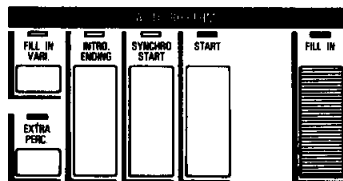

[FILL IN VARIATION]



This feature offers you an alternative Fill In pattern.

[Additional Information]

- Should you desire a longer Fill In pattern, hold down the FILL IN button.
- If you press the FILL IN button before starting the rhythm, the Fill In pattern will act as an intro.

INTRO./ENDING (ME-55A/ME-35A)

1 Press the **INTRO./ENDING** switch and then press the **start** switch.

You will now hear a one measure rhythm introduction.

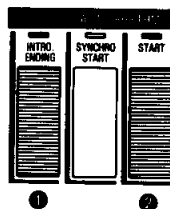

2 When you are almost finished with a song, press the **INTRO./ENDING** switch.

At the moment this switch is pressed, an ending pattern (two measures maximum) is played. As soon as the ending pattern is completed, the rhythm will stop automatically.

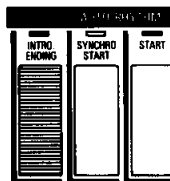

- **INTRO./ENDING** can be used even when **Synchro Start** has been used to start the rhythm.

EXTRA PERCUSSION (ME-55A/ME-35A)

This feature will add additional percussion sounds to the normal rhythm patterns.



- Some of the instruments added in Extra Percussion are hand clap, tambourine and cow bell, and vary from rhythm to rhythm.

FOOT SWITCH (ME-55A only)

1 Press one of the **FOOT SWITCH** selectors and start the rhythm.

This allows you to stop (and restart) the rhythm with the Foot Switch.



This will allow you to add a Fill In pattern with the Foot Switch.

2 Move the **Foot Switch** to the left.

At the time the Foot Switch is moved, the function selected in (1) will be immediately performed.

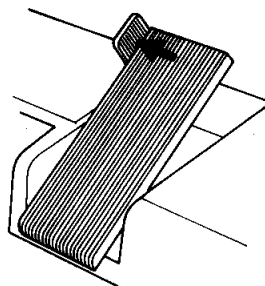

[ENDING Control]

If both the **RHYTHM STOP** and **RHYTHM FILL IN** buttons are on, and the foot switch is moved to the left, you will obtain an ending pattern and then the rhythm will stop.



When both **FOOT SWITCH** selectors are **OFF**, the **Glide** effect can be obtained. (See page 7.)

[Additional Information]

- When **RHYTHM STOP** is used to stop the rhythm, the Foot Switch can also be used to restart it again. The lamp above the **STOP** button will flash until the rhythm is reactivated.

4. Having Fun With Automatic Accompaniment

AUTO BASS CHORD

This function automatically produces chord and bass accompaniment. There are three different ways that you can use this feature, and we're sure that you'll find one just right for you.

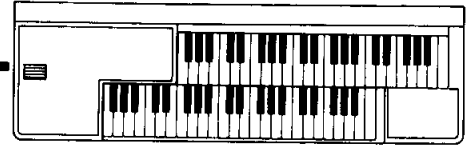

SINGLE FINGER

This feature allows you to obtain many different chords (and bass) by using just one finger.

1 Press the button labeled SINGLE FINGER.



(Illustration of ME-55A)

2 Select an Arpeggio Chord (for ME-15A, Rhythmic) pattern and your desired volume level. (See page 5.)

Arpeggio Chord provides the rhythm accompaniment for A.B.C. You can also add other lower keyboard voices to your accompaniment.

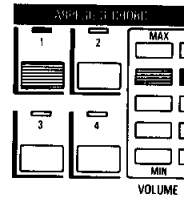

3 Select a pedal sound and your desired volume level. (See page 3.)

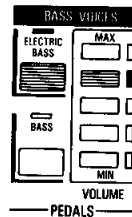

4 Select a rhythm. (See page 8.)

Once you've chosen a rhythm pattern, adjust the tempo to a speed comfortable for you. Then set your desired volume level and turn on SYNCHRO START.

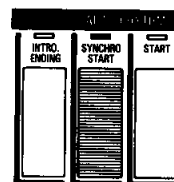

5 Press a key on the lower keyboard.

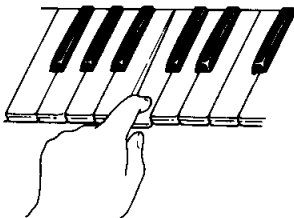

You will now hear a major chord and bass accompaniment in synchronization with the rhythm.

The note you have played is called the "root". A chord derives its name from its root such as C major, F major, etc.

[Relationship between the lower keyboard notes and corresponding major chords]

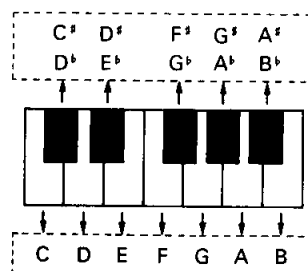

[Let's Try Playing Other Chords!]

Minor chords: Simultaneously press the root (name) as well as any black key to the left of it. (Example: Am)



Seventh chords: Simultaneously press the root (name) as well as any white key to the left of it. (Example: G7)



Minor seventh chords: Simultaneously press the root (name) as well as any black key and any white key to the left of it. (Example: Gm7)



[Additional Information]

- When you change Arpeggio Chord patterns, the bass pattern will automatically be changed.
- With Single Finger, the chord produced will sound in the same octave regardless of where it is played on the lower keyboard.
- When you want to change chords, please lift your finger completely from the lower keyboard for a moment before pressing the next key.

MEMORY

This feature allows the chord and bass accompaniment to continue even after you have lifted your fingers from the lower keyboard.

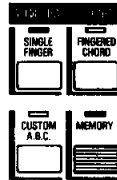

(Illustration of ME-55A)

●Memory is linked with the auto rhythm and therefore will operate only if the rhythm is on (whether or not Auto Bass Chord is in use).

FINGERED CHORD

This feature permits you to play a variety of chords and will automatically provide the proper bass note.

1 Press the button labeled FINGERED CHORD.

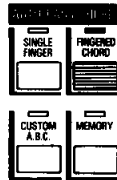

2 Select an Arpeggio Chord (for ME-15A, Rhythmic) pattern and your desired volume level. (See page 5.)

You can also add other lower keyboard voices to your accompaniment.

3 Select a pedal sound and your desired volume level. (See page 3.)

4 Select a rhythm. (See page 8.)

Once you've chosen a rhythm pattern, adjust the tempo to a comfortable speed and set your desired volume. If you use SYNCHRO START, the automatic accompaniment and rhythm will start when you play a chord on the lower keyboard.

5 Play a chord on the lower keyboard.

You will now hear a chord and bass accompaniment in synchronization with the rhythm. The chord you play forms the basis for the automatic accompaniment. You can also add Memory, if you like.

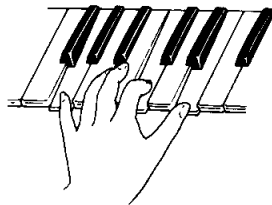

[Examples of Fingered Chords]

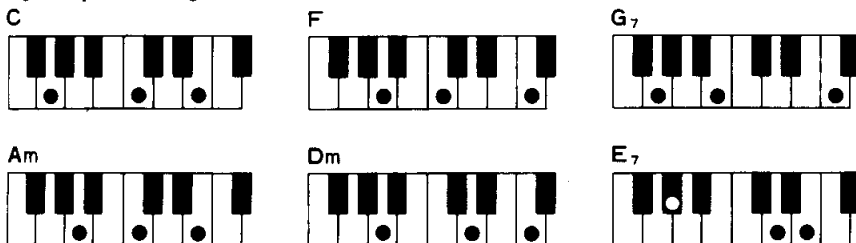

With Fingered Chord, a variety of other chords becomes available to you, above and beyond the four basic types obtainable with Single Finger.

Your Electone will automatically play the proper bass accompaniment to whatever chord you play.

[CUSTOM A.B.C.]

Custom A.B.C. allows you to play a chord and a pedal, and it will automatically create accompaniment patterns for you!

1) Press the button labeled CUSTOM A.B.C.

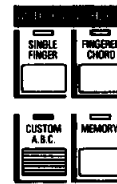

2) Choose instruments for the lower keyboard (including Arpeggio Chord or Rhythmic if you like) and the pedal keyboard. Set all volumes to the level of your choice.

3) Select a rhythm.

4) Play a chord on the lower keyboard and press one note on the pedal keyboard.

You will now hear a chord and bass accompaniment in synchronization with the rhythm. Since the note pressed on the pedal keyboard can be any note (i.e., it does not have to be the "root" of the chord played on the lower keyboard), more sophisticated automatic accompaniments become available to you.

[Additional Information]

●When Auto Bass Chord is used without the auto rhythm, your Electone will still provide the chords and bass, but the background will be stationary (not "animated").

Note: Arpeggio Chords and Rhythmic will not work without rhythm. (See page 5.)

●Some of the chords available in the Fingered Chord mode are the following: major, minor, 7th, minor 7th, major 7th, dim, aug, aug7, sus4, 7sus4, 6th, min7-5, major-5, 7-5, min6.

●When using Custom A.B.C., the MEMORY button will be used to memorize only the bass accompaniment.

●In the Custom A.B.C. mode, when playing pedals that are not necessarily a part of the chord, select from the upper row of Arpeggio Chord buttons (strumming patterns).

5. Harmonizing the Melody [ME-55A/ME-35A]

MELODY ON CHORD

With this function, single note melodies are transformed into beautiful harmonies automatically, enhancing your playing even further.

1 Press one of the MELODY ON CHORD buttons.

This will automatically add two notes to your melody.



This will automatically add three notes to your melody.

2 Select an instrument to play the melody. (See page 2.)

Select the sound you want to use to perform your melody from among the voices available on the upper keyboard, and set the volume level.

3 Select your Harmony voices.

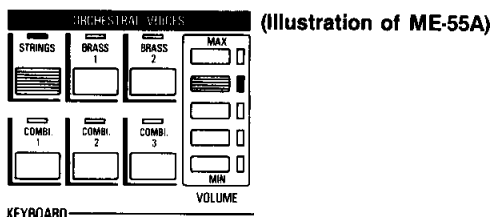

Select the sound with which you want to perform your melody from among the voices available on the upper keyboard, and set the volume level.

4 Select a voice for the lower keyboard. (See pages 3 and 5.)

Once you've chosen one, remember to set your volume level.

5 Play a chord on the lower keyboard and the melody on the upper keyboard.

Harmonies will be automatically added to the melody, and your playing will sound more professional than ever!

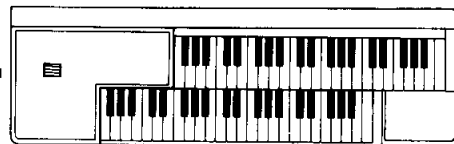

[When both Buttons 1 and 2 are turned on]



If MELODY ON CHORD 1 and 2 buttons are used simultaneously, you will obtain a three note harmony that is somewhat reminiscent of "open harmony".

[Use this feature with Auto Bass Chord tool]

MELODY ON CHORD 1 and 2 can also be used with A.B.C. For example, if you use Single Finger, the chords automatically produced (by one finger) will be added as harmonies to the melody. If Memory and Auto Rhythm are in use, the harmonies will continue even after you have lifted your fingers from the lower keyboard.

[Additional Information]

- The automatically added harmony sound is derived from chords played on the lower keyboard. Therefore, no harmony will result when you play only the upper keyboard.
- When a melody is played on the lower range of the upper keyboard, harmony sounds will sometimes not be produced.

6. Memorizing Your Favorite Registrations

REGISTRATION MEMORY

This feature lets you store some of your favorite sounds in memory and have them conveniently accessible at the touch of a button.

How to Memorize a registration

1 By using the control panel, set up your desired registration.

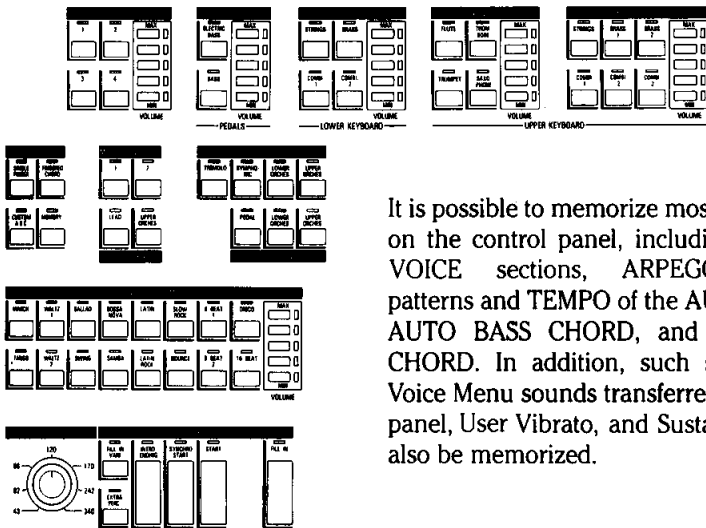

It is possible to memorize most of the settings on the control panel, including the various VOICE sections, ARPEGGIO CHORD, patterns and TEMPO of the AUTO RHYTHM, AUTO BASS CHORD, and MELODY ON CHORD. In addition, such settings as the Voice Menu sounds transferred to the control panel, User Vibrato, and Sustain settings can also be memorized.

2 While pressing the red M. (Memory) button, press the numbered button (1, 2, 3, 4, 5) where you wish to store the sound.

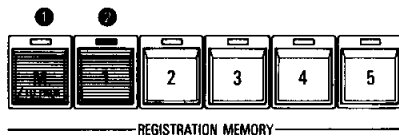

The lamp above the numbered button you pressed will flash briefly, indicating that this registration has been memorized here. Store your other favorite registrations in the same way, utilizing the remaining numbered buttons.

How to Recall a Registration From Memory

1 Press one of the numbered buttons.



As soon as a numbered button is pressed, the registration that was placed in memory will instantly be set up on the control panel.

2 Additional registrations can be recalled by pressing the appropriate numbered buttons.



Whenever you press a different numbered button, the control panel setting will instantly change. You can easily see what settings have been memorized.

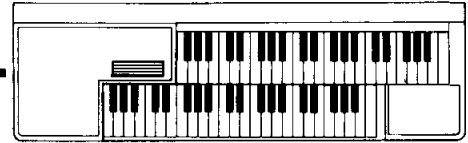

[The Memorization Operation and Button Lamps]



Though the lamp of one of Registration Memory buttons 1-5 is always lit, the memorization operation for registration data can be performed regardless of the ON/OFF status of the lamps.

When memorizing a registration to a lit button: The new registration is stored at the lit button. The pertinent lamp will flash during the memorization process, then return to its lit status.

When memorizing a registration to an unlit button: A new registration is stored at that unlit button which already contains registration data, but the memory contents of the lit button remains unchanged. The lamp of the unlit button will flash only during the memorization process, then return to its unlit status.

[Altering a Registration]

Any registration may be altered to any extent by simply changing the desired controls.

Even if you have changed the control panel settings, the memorized registration will not be affected and will remain as it was programmed. If you wish this "altered" registration to be stored in memory, simply hold M. (Memory) button, and press the numbered button (1,2,3,4,5) where you wish to store it.

[Protecting Memorized Data]

The data stored in Registration Memory will be retained for at least a week, even when the power is turned off. The memorized data can also be stored by transferring it to a RAM Pack or a cassette tape. (See pages 14, 25.)

[Additional Information]

- Registration Memory will not affect the following: Start, Synchro Start, Fill In, Intro./Ending, C.S.P., Transposition, Cassette, Master Volume, Expression Pedal.
- When using C.S.P., the data stored in Registration Memory will be replaced. (See page 19.)
- When a registration is stored in one of the numbered buttons, the previous contents of that respective memory are automatically replaced.
- If the power is turned off for a long period of time, the sounds stored in the Registration Memory section will be automatically replaced by the sounds from the Basic Registration. The previous registrations will be erased.

7. Transferring Information to a Pack

PACK

It is possible for the information of Registration Memory and of C.S.P. (see Page 19) that has been memorized into the Electone to be transferred to a RAM Pack (optional). Also, the information transferred to a RAM Pack can be transferred back to the Electone.

How to Transfer Information to a RAM Pack (TO PACK)

1 Memorize the desired information into Registration Memory or C.S.P. (See pages 13 and 19.)

2 Insert a RAM Pack (RP-3) into the Electone. Insert the RAM Pack securely into the Electone so that its top side (with the label) faces left. The green READY lamp will light up.

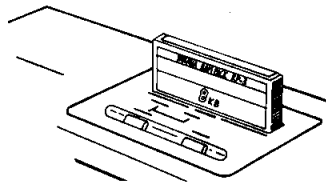

3 While depressing the CONFIRM button, press the TO PACK button.

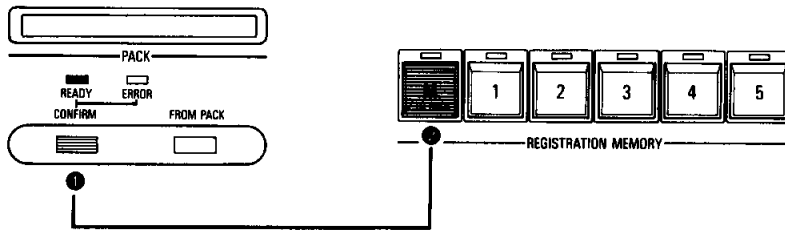

With the CONFIRM button pressed down, press the TO PACK button. (The TO PACK button also functions as the MEMORY button of Registration Memory.) The READY lamp will flash several times to indicate that the Electone's information has been transferred to the RAM Pack.

How to Return Information from the RAM Pack (FROM PACK)

1 Insert the RAM Pack, which contains the transferred information, into the Electone. The green READY lamp will light up.

2 While depressing the CONFIRM button, press the FROM PACK button.

With the CONFIRM button pressed down, press the FROM PACK button. The READY lamp will flash to indicate that the information of the RAM Pack has been transferred back to the Electone.

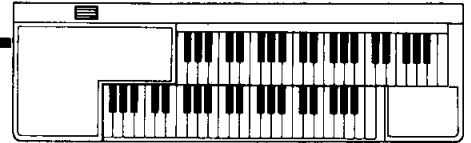
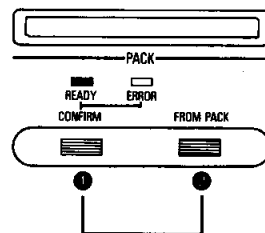

[MEMORY PROTECT]

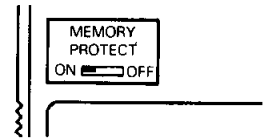

If you wish to prevent the information that was transferred to the RAM Pack from being erased, set the MEMORY PROTECT switch of the RAM Pack to "ON". Even if you later unintentionally attempt a TO PACK operation, the information previously memorized into the RAM Pack will be protected without the new information being memorized. (The FROM PACK operation, however, can be executed.) Furthermore, if you wish to memorize new data onto that RAM Pack at a later time, just return the MEMORY PROTECT switch to "OFF".

[If the ERROR lamp flashes]

In the following cases, the red ERROR lamp will flash for about one second and the alarm will sound three times. Please check that you are using the proper operating procedures.

- When an unused RAM Pack is first inserted into the electone. (In this case, press the CONFIRM button then perform the TO PACK operation.)
- When the Pack is not completely inserted.
- When a TO PACK operation is attempted while the MEMORY PROTECT switch of the RAM Pack is set to "ON".
- When the information memorized in the RAM Pack is for an Electone of a different model.

[Precautions on RAM Pack Use]

- When a TO PACK operation is performed, the previously stored information in that RAM Pack is erased and written over with the new information. When the FROM PACK operation is performed, the previously stored information in the Electone is erased and written over with the information from the RAM Pack.
- When transferring information memorized in a RAM Pack back to an Electone, be sure that an Electone of the same model is being used.

II. MULTI MENU (ME-55A/ME-35A only)

1. You Can Recall 16 Different Registrations

REGISTRATION MENU

These two menu pages offer 16 preprogrammed registrations that can be used directly from the Multi-Menu, all available at the touch of a button.

REGISTRATION MENU 1	1	2	3	4	5	6	7	8
REGISTRATION MENU 2	9	10	11	12	13	14	15	16

1 Press one of the buttons in REGISTRATION MENU 1 or 2.

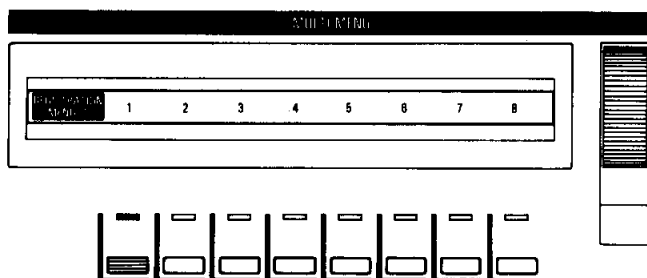

That registration will now be set up on the control panel (including voices on each keyboard, volumes, rhythm selection, effects and A.B.C.)

2 ...and you're ready to play!

Start the auto rhythm, and start playing. Take a few moments to listen to the remaining registrations.



[Altering a Preprogrammed Registration]

When using the Registration Menu, any registration may be altered to any extent by simply changing the selected controls. In fact, you may want to store the "altered" Registration as new registrations in the Registration Memory.

[Additional Information]

- The Registration Menu not only uses the sounds normally available on the control panel, but in some cases, the sounds from the Voice Menus that have been transferred to the "grey" buttons. (See page 16.)
- All Registration Menu settings have been preprogrammed using the Single Finger (Chord) mode. To use Fingered Chord or Custom A.B.C., press the respective button to alter the setting.

[The preset sounds]

REGISTRATION MENU 1	Music Style	Rhythm used
1	March/Polka	MARCH
2	Pipe organ	(8 BEAT 1)
3	Woodwind ensemble	MARCH
4	Jazz organ	BALLAD
5	Jazz combo 1	SWING
6	Jazz combo 2	BOSSANOVA
7	Big band 1	SWING
8	Big band 2	BALLAD

REGISTRATION MENU 2	Music Style	Rhythm used
9	Country	MARCH
10	String ensemble	8 BEAT 1
11	Pops ensemble 1	8 BEAT 1
12	Pops ensemble 2	LATIN ROCK
13	Pops ensemble 3	SAMBA
14	Fusion sound 1	16 BEAT
15	Fusion sound 2	DISCO
16	Fusion sound 3	BOUNCE

2. 22 Additional Voices Can be Transferred To The Control Panel

VOICE MENU

You can choose your favorites from among these 22 voices and transfer them to the grey buttons on the control panel.

VOICE MENU 1	PIPE ORGAN	COSMIC BRASS 1	COSMIC BRASS 2	PIANO	ELECTRIC PIANO	HARPSICHORD	ORIGINAL VOICE	MENU ON
VOICE MENU 2	ACOUSTIC GUITAR	ELECTRIC GUITAR	JAZZ GUITAR	STEEL GUITAR	DISTORTION GUITAR	CLAVI	TIMPANI	WHISTLE
VOICE MENU 3	PAN FLUTE	CLARINET	FLÜGEL HORN	SOPRANO SAX	HARMONICA	COSMIC 1	COSMIC 2	CONTRA BASS

How to Transfer Sounds

1 Display the VOICE MENU 1 page and turn on the MENU ON button.

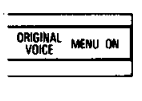

2 Decide which voice you wish to transfer and where you want to transfer it.

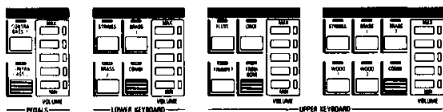
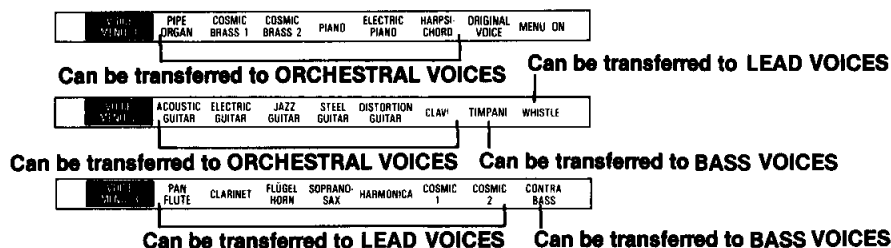

The grey buttons are located in the lower right corner of the voice sections. You can transfer any voice you want to any voice section.

3 While holding the button corresponding to the voice you'd like to transfer, press one of the grey buttons to indicate where you want to put that sound.

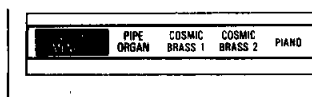
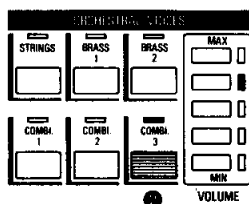

The light above the grey button you just pressed will start to flash, indicating that the sound has been transferred. Now, try transferring other voices in a similar manner.

Cancelling and Recalling

1 Turn off the MENU ON button.

At this time, the voices transferred to the grey button (in the various voice sections) will be cancelled and these grey buttons will now contain the voices indicated above each of them.

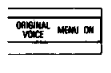
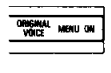

2 Turn on the MENU ON button.

The VOICE MENU sounds that were previously transferred to the grey buttons will now be recalled. These sounds will remain as transferred regardless of the page displayed on the MULTI MENU.

[Checking the Transferred Voices]

When the MENU ON button is on, and you press a grey button, the voice which has been transferred to that grey button will illuminate on one of the pages of VOICE MENU. If no voices have been illuminated on that Voice Menu, be sure to check the other Voice Menus.

If no voice had been transferred to that grey button, the light corresponding to "ORIGINAL VOICE" will illuminate, meaning that the sound indicated above that grey button has not been changed.

[ORIGINAL VOICE]

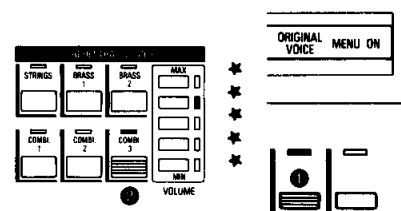

By pressing this button, you can cancel the VOICE MENU sounds transferred to the grey buttons, one at a time, thereby returning these grey buttons to the voice indicated on the control panel. To operate, hold the ORIGINAL VOICE button, and press the grey button that you wish to cancel.

[Additional Information]

- The voices transferred to grey buttons can be memorized in the C.S.P. and REGISTRATION MEMORY.
- The voices transferred to the grey buttons can be stored for at least a week without being erased even if the power is turned off.
- When VOICE MENU settings have been transferred to LEAD or BASS VOICES, they automatically become "monophonic" voices, meaning that only one note at a time can be played.
- The 22 voices can all be transferred to any desired voice section. Note, however, that due to differences in the pre-programmed vibrato effect for each voice, voices transferred to sections other than those mentioned in step 2 will give a somewhat different impression than intended. In such a case, the original characteristics of that voice can be obtained by changing the User Vibrato setting. (Please see page 17.)
- The same voice can also be transferred to the grey buttons in more than one section.

3. You Can Also Memorize Vibrato and Sustain Effects

USER VIBRATO

A Vibrato effect, where appropriate, is already incorporated into the LEAD VOICES and ORCHESTRAL VOICES of the upper keyboard. However, you can alter the degree of the Vibrato effect to suit your personal taste, and this change can also be stored in memory.

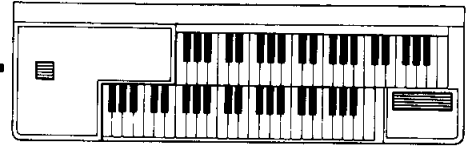

1 On the control panel, turn on the **USER VIBRATO LEAD** button, then select a **LEAD VOICE**.

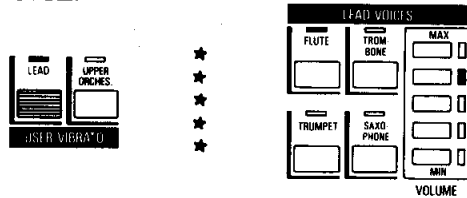

[Memorizing the Vibrato Effect for the Upper ORCHESTRAL VOICES]

- 1) On the control panel, turn on the **USER VIBRATO UPPER ORCHES.** button, then select a voice from **ORCHESTRAL VOICES** on the upper keyboard.
- 2) Turn on the **U. ORCHESTRAL DEPTH** button, then select the level of **Vibrato Depth** you prefer.

2 In the **MULTI MENU**, press the **U. LEAD DEPTH** button, then select the level of **Vibrato Depth** you prefer.

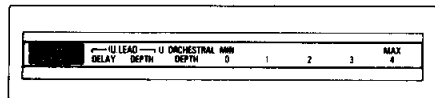
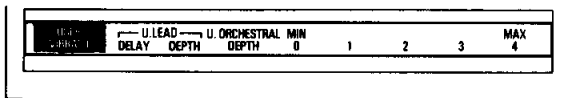

- 3) By turning on the **USER VIBRATO UPPER ORCHES.** button on the control panel, your customized **Vibrato** effect will be obtained.

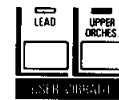

While actually playing a note, press one of the 5 degrees buttons. The larger the number, the stronger the vibrato effect obtained. If you choose the 0 button, no **Vibrato** effect will be added.

3 Turn on the **U. LEAD DELAY** button, then set your desired **Delay** level.

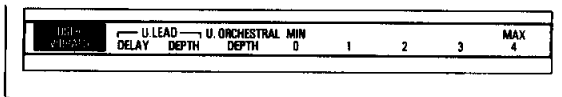

Similarly, you may choose from a total of 5 buttons. The larger the number, the longer it will take for **Vibrato** to be added after pressing a key on the upper keyboard.



4 Turn this **LEAD** button on, whenever you wish to add your customized **Vibrato**.

Your memorized **Vibrato** settings can be added to the **Lead Voices** at any time by simply turning this button on.

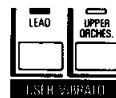

[Additional Information]

- A customized **Vibrato** setting will be memorized into the **C.S.P.** or **Registration Memory**.
- The **Vibrato** setting memorized in the **USER VIBRATO** memory will be stored for at least a week without being erased, even if the power is turned off.

SUSTAIN

This Multi Menu page permits you to memorize a Sustain effect for each keyboard.

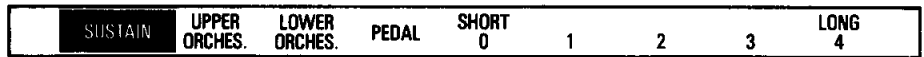
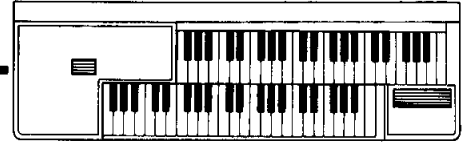

1 Turn on the **SUSTAIN UPPER ORCHES.** button, then select a voice from **ORCHESTRAL VOICES** on the upper keyboard.

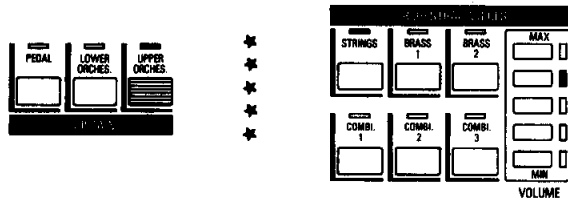

2 In the **MULTI MENU**, press the **UPPER ORCHES.** button then set the Sustain length of your choice.

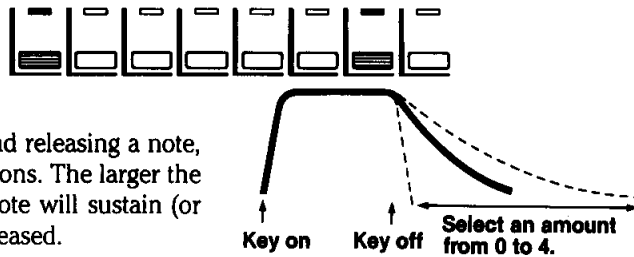
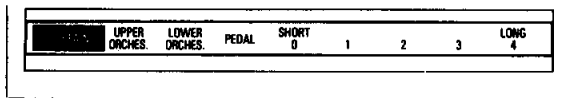

While actually pressing and releasing a note, choose one of these 5 buttons. The larger the number, the longer the note will sustain (or "linger") after a key is released.

3 Turn the **UPPER ORCHES.** button on, whenever you wish to add your desired sustain level to the upper keyboard.

Your memorized sustain settings can be added to the upper **ORCHESTRAL VOICES** section at any time by simply turning this button on.



[Memorizing the Sustain Effect for the BASS VOICES or Lower ORCHESTRAL VOICES]

- 1) On the control panel, turn on **SUSTAIN PEDAL**, then select a Bass voice.
- 2) Press the **PEDAL** button on the **MULTI MENU** Sustain page, then set the Sustain length to your desired level.

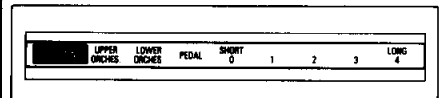

3) By turning on **SUSTAIN PEDAL** on the control panel, your customized Sustain effect will be produced.



The Sustain effect for the **LOWER ORCHESTRAL VOICES** can also be memorized by using this same procedure.

[Additional Information]

- Customized Sustain settings will be memorized into the **C.S.P.** or **Registration Memory**.
- The Sustain setting memorized in **SUSTAIN** memory will be stored for at least a week without being erased, even if the power is turned off.

4. Transposing

TRANSPOSITION

This feature allows you to change the key of the entire instrument in half step increments.

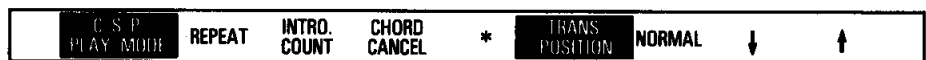

1 Press the (↓) or (↑) button.

(↓) button: The pitch will be lowered by one-half step each time this button is pressed. (Maximum: 6 steps)

(↑) button: The pitch will be raised by one-half step each time this button is pressed. (Maximum: 6 steps)

2 Press the **NORMAL** button to return your Electone to the normal key.

You can also return to the normal key by turning the **POWER** switch off and on.

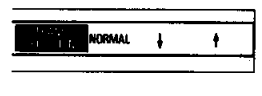
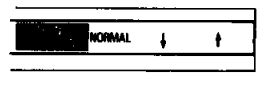

[Additional Information]

- The lamps corresponding to the (↓) button and (↑) button indicate whether the instrument's key is currently below or above normal.
- Transposition will not be memorized in **C.S.P.** or the **Registration Memory**.

5. Programming the Accompaniment

CHORD SEQUENCE PROGRAMMER

This feature allows you to easily memorize chord progressions as well as registrations one at a time by simply pressing certain buttons.

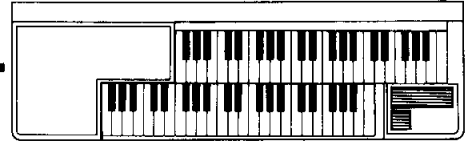

How to Record a Sequence

1 Memorize the voices, etc. to be used for the performance in Registration Memory, then select the registration you wish to use at the beginning of the song. (See page 13.)

Before you start programming, set the voices, rhythm patterns, etc. suited to the song you will perform, then store them at Registration Memory buttons 1-5. Next, press one of the Registration Memory buttons 1-5 to recall the registration you wish to use at the beginning of the song.

2 Turn to the Multi Menu page marked C.S.P. RECORD, then while pressing the  (treble clef) button, press the EDIT/CLEAR button.

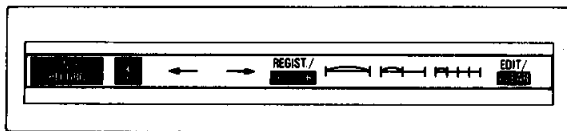

The two SONG buttons will start to flash.

3 Select one of the SONG buttons.

While these buttons are flashing, press one of them. The corresponding lamp for the song you have selected and the EDIT/CLEAR lamp will stay illuminated.

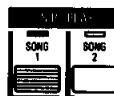

4 While playing the first chord, press a duration button.

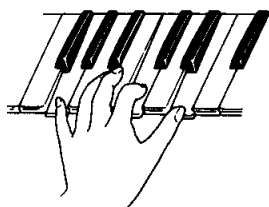

4 beat length (3 beats in case of waltz)
2 beat length
1 beat length

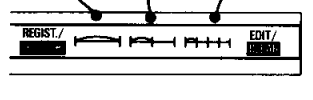

If you wish, you can use the SINGLE FINGER feature from the Auto Bass Chord section, thereby enabling you to memorize the chords by using a single finger. (See page 10 for details.)

When a duration button is pressed, you will hear a "beep", indicating that the chord has been stored in memory. Continue programming the remaining chords in this same manner.

[Registrations can be Memorized in C.S.P., too!]

The data stored at Registration Memory buttons 1-5 will be automatically programmed upon entering a recording operation. At such time, the data indicating which button is in ON status will also be programmed.

If a different numbered button (1-5) is pressed during programming then the REGIST. button is pressed, the data indicating the number of the newly selected button will be programmed. Registration data that is changed at the panel, however, will not be programmed.

Though the majority of data stored in Registration Memory is programmed as is into C.S.P., note that Your Electone is designed so that only the Rhythm Tempo and Auto Bass Chord settings will not be programmed.

[Memory Capacity]

Each of the SONG buttons can store up to about 150 events such as chords, Fill In, etc., in its memory. When this memory is completely full, a warning sound (3 beeps) will be heard.

[To program Chordless Measures]

If you wish to program a measure without chords, simply press a duration button without playing any notes on the lower keyboard.

[Additional Information]

● Before programming, make sure that the SONG 1 and 2 buttons are off before pressing the Treble Clef and EDIT/CLEAR buttons.

5 If you wish to add a Fill In pattern at any point, while pressing the Fill In button, press the REGIST. button.

The Intro./Ending patterns can also be preprogrammed. See [Intro./Ending Program] on the right.

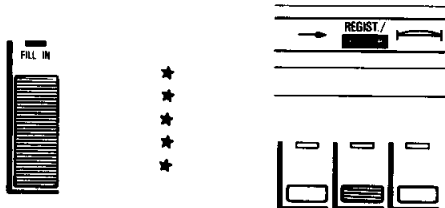

6 If registration changes are desired during programming, while pressing the appropriate numbered button in the Registration Memory section, press the REGIST. button.

From this point on, the new registration will be used.

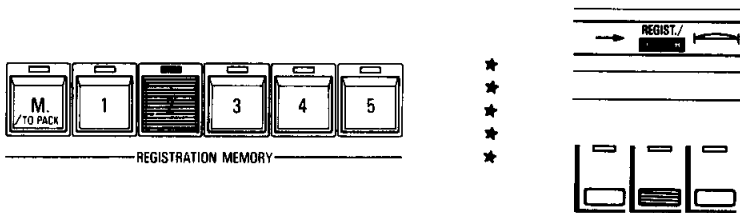

7 When you have completed the chord sequence, end the program by holding down the treble clef button then pressing the REGIST./ (ending) button.

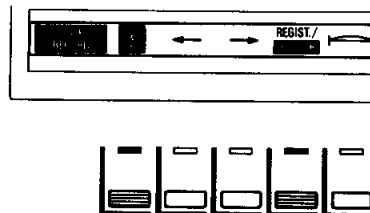

8 Turn OFF the EDIT/CLEAR button.

Because the SONG button remains ON though the EDIT/CLEAR button is turned OFF, if the rhythm is started in that status, you can play back the chord progressions that you just recorded. Moreover, if you wish to record on another SONG button, turn the SONG button that is ON to OFF then perform Steps 1 to 8.

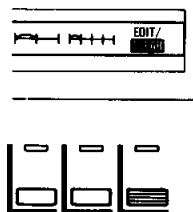

[Intro./Ending Program]

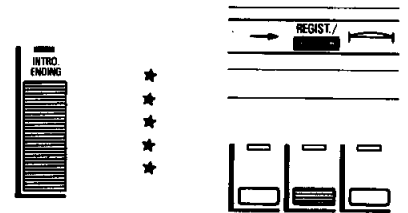

Intro.: At the beginning of the program, while pressing the INTRO./ENDING button, press the REGIST. button. Next, press the (→) button to ensure that no chords are heard during this one-measure introduction.

Ending: At the beginning of the second measure from the end of the song, while pressing the INTRO./ENDING button, press the REGIST. button, thereby programming a two-measure ending.

[Additional Information]

- Before turning off the EDIT/CLEAR, you may want to check what you have programmed and make any corrections that you feel are necessary. (See page 24 for details on how to EDIT.)
- Even if you don't use the ending symbol, it will automatically be added at the end of a song when the EDIT/CLEAR button is turned off.
- It is not possible to consecutively memorize different registrations without musical data between them. If you make a mistake in registration during programming, press the (←) button and then enter the correct registration.



How to Play Back a Sequence

1 Select one of the SONG buttons.

The registration memorized for the beginning of the song will be set up on the control panel.



2 Turn to the C.S.P. Play Mode page in the Multi Menu. If you wish, you can now select either the REPEAT or INTRO. COUNT functions.

REPEAT provides a continuous playback of the sequence until it is stopped. INTRO. COUNT provides one measure of "metronome" (count-off) before the actual playback of the sequence starts.

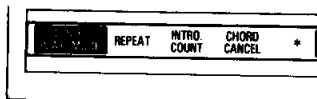

3 Start playback by turning on the auto rhythm.

Adjust the rhythm tempo and press the START switch. Playback will commence.

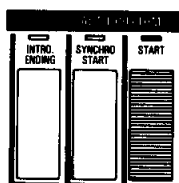

4 You may now play the melody while the lower keyboard and pedal keyboard accompaniment are being played back automatically as programmed.

You may now play a melody on the upper keyboard along with this accompaniment. The registrations will also change automatically as programmed.

When playback has been completed, the auto rhythm will stop (unless REPEAT is on).



[Chord Cancel]



This button cancels the playback of the chord and bass accompaniment. In this way you can play the song manually, and use any registration changes programmed in the sequence. You might say that you have a "Registration Sequence Programmer" too!

[Protecting C.S.P. Data]

The memorized data will be retained in the C.S.P. memory for at least one week even if the power is turned off.

If you wish to store these sequences for a longer period of time, you can use a RAM pack or cassette tape for this purpose. (See pages 14 and 25 for details.)

[Additional Information]

- The C.S.P. Play Song buttons will operate at any time regardless of the position of the Multi Menu.
- You can also manually change registrations during C.S.P. playback from the control panel without affecting the contents of C.S.P. memory.
- When the C.S.P. Play Song 1 or 2 buttons are pressed, the control panel settings (and Registration Memory contents) will be replaced by those used during programming (Recording).

Let's Use C.S.P. (CHORD SEQUENCE PROGRAMMER)

◆ Sample 1 ◆

Setting the Registration

- ① Press [3] on the REGISTRATION MENU.
- ② Set the tempo to about [86].
- ③ Change the AUTO BASS CHORD mode from FINGERED CHORD to SINGLE FINGER.
- ④ While pressing [M.] of the REGISTRATION MEMORY, press [1].

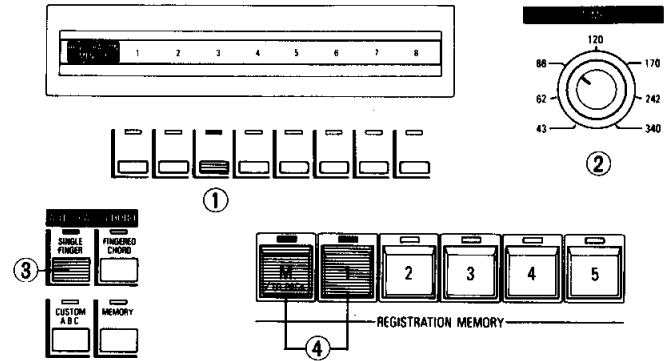

Preparing to Start Programming

- ① While pressing [C], press [EDIT/CLEAR]. (The SONG lamps will begin flashing.)
- ② Press the flashing [SONG 1] button.

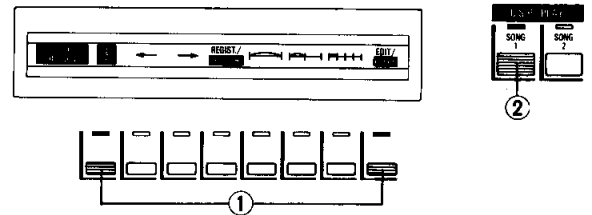

Programming the Chords

Mary Had a Little Lamb

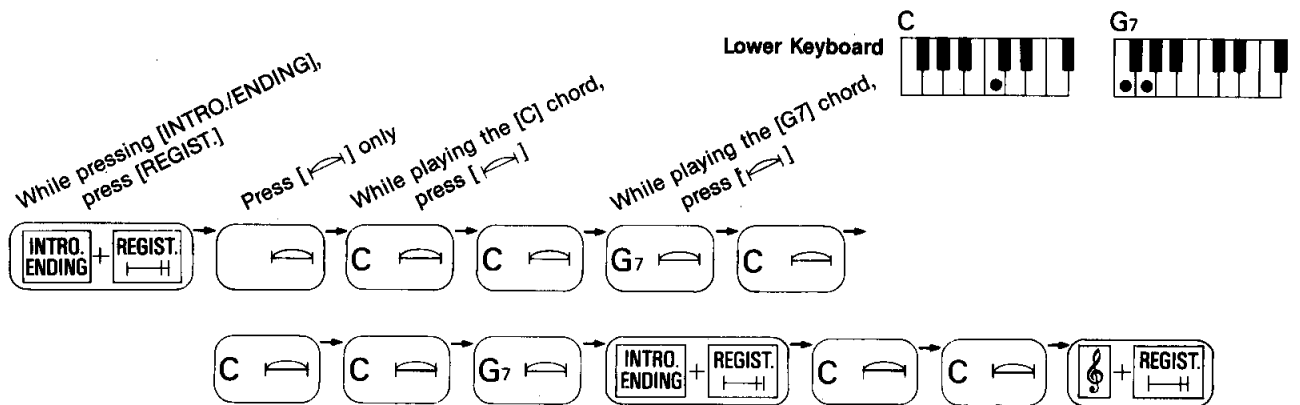

*To program a chord, while pressing the appropriate keys of the lower keyboard to sound the desired chord, press [C]. A chord will not be programmed if the lower keyboard keys are released too quickly.

Ending the Programming and Starting to Play

- ① Press [EDIT/CLEAR] once more to turn off its lamp.
- ② Start the rhythm.
- ③ After the one-measure Intro. pattern is over, begin playing the melody on the upper keyboard.

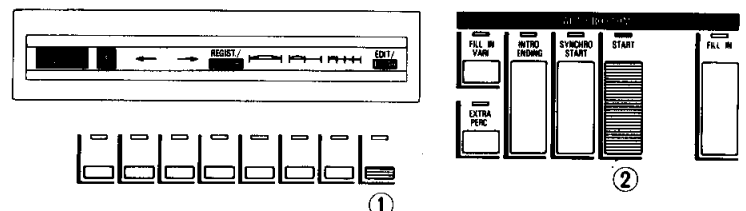

◆ Sample 2 ◆

Setting the Registration

- ① Press [7] on the REGISTRATION MENU.
- ② Set the tempo to [120].
- ③ Set the AUTO BASS CHORD mode to SINGLE FINGER.
- ④ While pressing [M.] of the REGISTRATION MEMORY, press [2].

Preparing to Start Programming

- ① While pressing [], press [EDIT/CLEAR].
- ② Press the flashing [SONG 2] button.

Programming the Chords

Little Brown Jug

Intro.

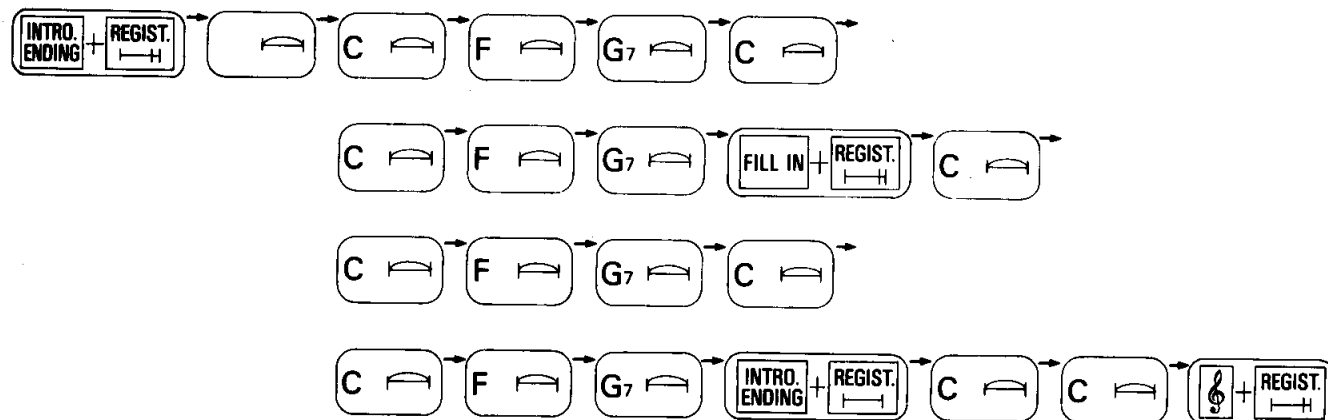

Ending the Programming and Starting to Play

- ① Press [EDIT/CLEAR] to OFF.
- ② Start the rhythm.
- ③ After the one-measure Intro. pattern is over, begin playing the melody on the upper keyboard.



Making Changes/Corrections in the Sequence

1 Press the EDIT/CLEAR button, and while the SONG lamps are flashing, select one of them.

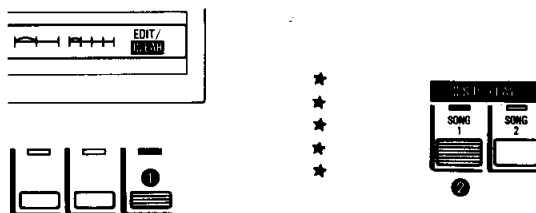

The registration memorized for the beginning of the song is immediately set up on the control panel, and the first memorized chord will be heard. One of the duration buttons will also be illuminated.

2 Check each item, one at a time, using the (→) data pointer shift button.

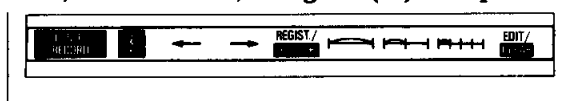

(One of these lamps will light up, indicating what has been memorized.)

Every time the (→) button is pressed, the data pointer will advance to the next item. The information stored at each item is indicated by sounds and lamps in the following manner:

Chords: The memorized chord will be heard and the corresponding duration button will light up.

Fill In, Intro./Ending or Altered Registration: The REGIST. lamp lights up, no sound is heard, and the FILL IN or INTRO./ENDING lamp will be illuminated.

If registrations have been changed, the REGIST. lamp lights up and the control panel is changed to the new registration.

3 If you detect any errors or wish to make any changes, make them in the following way.

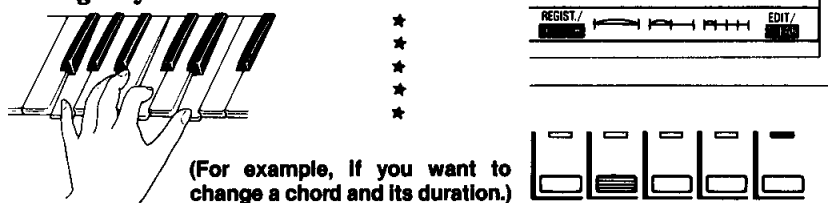

(For example, If you want to change a chord and its duration.)

When making Changes/Corrections, move the data pointer to the point where you wish to make the change and do the following:

Chord correction: While playing the correct chord, press a duration button.

Duration correction: While playing the same chord, press the correct duration button.

Inserting Fill In, Intro./Ending or Registrations: First move the data pointer to the next data point after the desired position of insertion. Next, turn on FILL IN or INTRO./ENDING then press the REGIST. button. Also, changing to a different numbered button in the Registration Memory then pressing the REGIST. button allows a new registration to be inserted.

4 Turn off the EDIT/CLEAR button.

[Various Ways of Using the Data Pointer Shift buttons]

There are four different ways you can use the data pointer shift buttons. They are shown in the following table:

→	Advances to the next item (one at a time).
←	Moves back to the preceding item (one at a time).
→ (with square icon)	Immediately advances to the last item in the sequence.
← (with square icon)	Immediately moves back to the first item in the sequence.

[Revising a Preprogrammed Registration]

If the data pointer is at the very beginning of a song, you can change the beginning registration by changing to your new registration and then pressing the REGIST. button.

While EDIT/CLEAR is on, if a new (or revised) registration is stored in Registration Memory, it can also be inserted into the program (see item #3 on the left).

[Checking with the rhythm ON]

While EDIT/CLEAR is on, when the rhythm is started, the programmed accompaniment will be played exactly as it would during normal playback. However, in this mode it is possible to stop the auto rhythm at any time during playback to correct any errors found.

[Additional Information]

● When you want to check or correct items after the EDIT/CLEAR button has been turned off, you must turn on the EDIT function.

IMPORTANT! If the [] and EDIT/CLEAR buttons are pressed at the same time, all of the memorized information will be erased.

● During the EDIT process, the original length of a song can only be altered by adding chords after the very last bit of data in the program.

6. Transferring Information to a Cassette

CASSETTE

The C.S.P. and Registration Memory data can be transferred to a cassette tape.

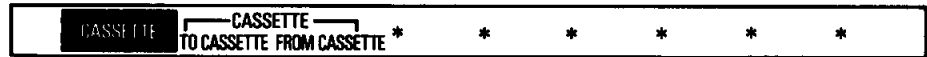

TO CASSETTE

1 Connect a data recorder to the Electone.

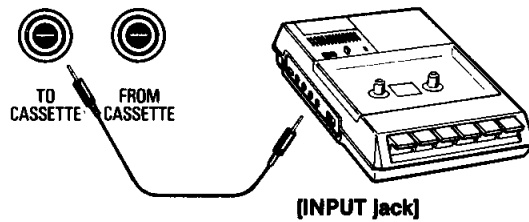

Connect the TO CASSETTE jack on the Electone to the IN (or MIC) jack on your data recorder using a shielded cable. Then insert a cassette tape. (Though an ordinary audio cassette recorder can be substituted for the data recorder, the use of a recorder specifically designed for data recording is recommended.)

2 Press the RECORD button on the data recorder.

If your recorder has a counter, you may wish to note the starting and ending numbers to facilitate later use.

3 Turn to the Multi Menu page marked "Cassette" then press the TO CASSETTE button.

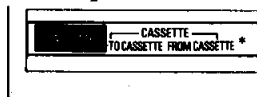

This starts the transfer of the C.S.P. data and also Registration Memory data in the Electone to the cassette tape. During this procedure, the TO CASSETTE indicator lamp will stay on. Once this procedure is completed, a buzzer will sound, the lamp will flash briefly, then go off. When the lamp goes out, press the STOP button of the data recorder.



FROM CASSETTE

1 Connect a data recorder to the Electone.

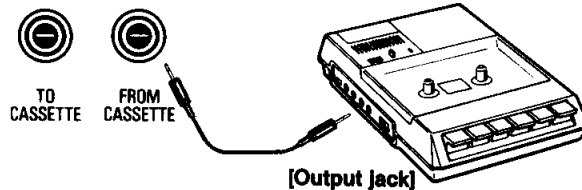

Connect the FROM CASSETTE jack on the Electone to the OUT (or EAR) jack on your data recorder using a shielded cable. Insert the cassette tape on which you have saved the desired data and rewind it to the point where the saving operation was started. Set the playback volume of the data recorder to a level slightly higher than medium level.

2 Press the FROM CASSETTE button in Multi Menu.

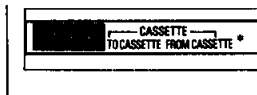

3 Press the PLAY button on the data recorder.

This starts the transfer of the data from the cassette tape to the Electone. During this procedure, the FROM CASSETTE indicator lamp will stay on. Once this operation is completed, a buzzer will sound, the lamp will flash briefly, then go off. When the lamp goes out, press the STOP button of the data recorder.



[When Data Cannot be Transferred]

When the TO CASSETTE procedure has not been properly performed, the TO CASSETTE lamp will remain illuminated. When the FROM CASSETTE function has not been properly performed, either three warning beeps are sounded or the FROM CASSETTE lamp remains lit up. In such cases, confirm the checkpoints below:

- (1) Is the cable between the Electone and data recorder securely connected?
- (2) Are the connecting jacks plugged into the proper sockets or is there an error in the operating procedure?
- (3) Is the playback volume of the recorder at the proper level?
When the VOLUME control has a 10-step scale, set the volume from 6 to 8.
- (4) Is the recording head dirty?
- (5) Is the proper cassette tape being used?

* Be sure to use a tape specifically designed for computer use or a normal low-noise audio tape (30- or 45-min. tape).

* Use only new tapes whenever possible.

* Check the tape for twists, seams, wrinkles, etc. (When using tape with a "leader" (i.e. normal audio tape), fast forward the tape past this "leader".)

- (6) Is an appropriate recorder being used?

With an ordinary audio cassette recorder, some of its characteristics may render it unusable for data recording or cause difficulties in recording. Use of a data recorder is strongly recommended.

[Additional Information]

- The TO CASSETTE or FROM CASSETTE procedure normally requires about 60 seconds
- During the TO CASSETTE or FROM CASSETTE procedure, you cannot play your Electone. Also, all indicator lamps on the control panel will go out.
- When the FROM CASSETTE procedure is performed, any data previously stored in the Electone will be erased.

ACCESSORY JACKS

● HEADPHONES Jack

This jack is used to connect headphones (optional). When headphones are connected, there will be no sound from the Electone's speakers. This allows you to play your Electone at any time without disturbing others.

IMPORTANT: Do not use this jack for any purpose other than headphones!



● AUX. OUT Jack

This jack is used to produce a more powerful sound by connecting an external amplifier or other devices. If this jack is connected to the LINE IN jack of a tape recorder, direct recording is also possible. (Nominal Impedance: 470Ω)



● EXP. IN Jack

This jack accepts a monaural signal from a synthesizer or similar accessory. The volume of the equipment connected here will be controlled by the Electone Expression Pedal.



● MIDI IN/OUT Jacks

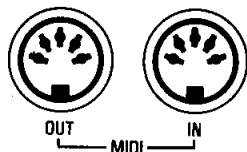

The MIDI (Musical Instrument Digital Interface) terminals

conform to the MIDI standard for digital electronic instruments. These jacks enable you to connect your Electone to a computer or other MIDI compatible electronic instruments for data communication.

● TO CASSETTE/ FROM CASSETTE Jacks (ME-55A / ME-35A)

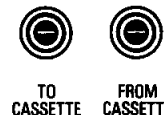

These jacks are used to connect the Electone to a cassette recorder for data transmission/reception. (See page 25 for details.)

WARNING: The connection or disconnection of any accessory (other than headphones) while the Electone is ON, can result in extensive damage to the Electone and/or the accessory. Damage caused by the improper connection/disconnection of accessories is not covered by the manufacturer's warranty.

ELECTROMAGNETIC INTERFERENCE

"Interference" can be a two way street; something you are operating can interfere with others or, something someone else has may interfere with something of yours.

Naturally, it is also possible that two or more of your own electronic (electric) devices may interfere with each other. Your Electone has been designed to minimize all these possibilities and meets all applicable standards worldwide.

Electromagnetic interference with your Electone can show itself in variety of ways. You may hear speech, music, "beeps", static, or a buzzing sounds. Yamaha Electones are designed to reject RF (radio frequency) signals that are many times the levels found in any normal environment. If, however, you are in the immediate proximity of a very high power transmitter, some interference may still occur. If this should happen, please try to identify the radio (TV) station and record the time of day that the interference occurs. Station identification is essential in order that the offending frequencies can be established and the authorized (legal) operating power level of the transmitter causing the interference can be verified. If the interference continues, please follow the suggested corrective measures provided later in this section.

If the interference is in the form of occasional buzzing or static, it is highly probable that the cause can be traced to the turning on or off of some household appliance. The offending appliance can also be outside your own residence. Usually a "time" pattern

(i.e., evenings only, etc.) will be involved. Noises of this type rarely originate in the Electone itself. If the condition continues, please contact your local authorized Yamaha Electone dealer for assistance.

Main power line disturbances and electrical storms (lightning) can also be the source of static interference. Generally speaking, problems generated by these two sources will also be present in your other audio or video equipment. Lightning can also be very destructive. The following special warning also applies to virtually all electronic products.

IMPORTANT NOTICE

Modern electronic products, (i.e., computers, video games, electronic organs, etc.), contain components that, under normal conditions, extend the service-free life of the products they make up to an almost unbelievable period of time. This is especially true when you consider the vast number of equivalent components incorporated within one given part. These "parts," called "integrated circuits," are however, subject to destruction by high voltage discharges, such as a close proximity lightning strike. This can occur even if the unit is turned off.

IN PERIODS OF ELECTRICAL STORM PROBABILITY, IT IS ADVISABLE THAT YOU DISCONNECT ANY ELECTRONIC DEVICE NOT ACTUALLY IN USE FROM ITS WALL SOCKET.

INSTALLATION AND MAINTENANCE

● Installation

1. **WARNING:** Do not allow your Electone or its bench to rest on or be installed over power cords of any type. An electrical shock and/or fire hazard could possibly result from this type of improper installation.
2. **WARNING:** Do not place objects on your Electone power cord or place it in a position where anyone could trip over, walk on or roll anything over it. An improper installation of this type creates a personal injury/fire hazard possibility.
3. **Main Power Supply Verification:** Your Electone has been manufactured specifically for the main supply voltages used in your area. If you should move, or if any doubt exists, please consult your local authorized Electone dealer for instructions. The main supply voltage is printed on the name plate.

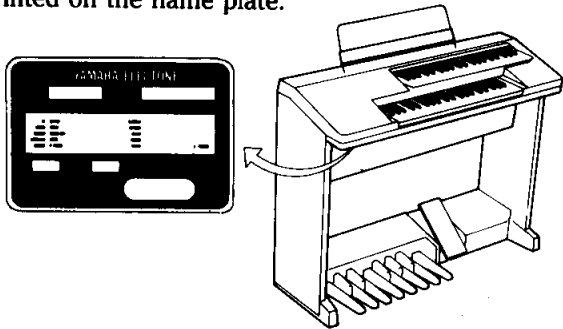

4. **Environment:** Your Electone should not be installed in a position that exposes the cabinet to direct sunlight or air currents having high humidity or heat levels. This type of installation can cause contact oxidation, case joint separation, and cabinet finish problems.
5. **Electromagnetic Interference (RFI):** Your Electone has been type tested and found to comply with all applicable regulations. However, if it is installed in the immediate proximity of other electronic devices, some form of interference may occur.

● Maintenance

1. **SERVICE:** Your Electone contains no user serviceable components. Refer all service to qualified service technicians only.
2. **BENCH STRUCTURAL INTEGRITY:** If any motion or an "unsteady" sensation is noted in the bench, please check its structural integrity immediately. Discontinue use until any and all discrepancies are resolved.
3. **CLEANING/CARE**
 - A) **GENERAL:** DO NOT use chemically harsh (i.e., alcohol, paint thinners, etc.) or abrasive cleaners on any portion of your Electone.
 - B) **KEYS/CONTROL PANEL:** When cleaning the keys and control panels of your Electone, please use a soft absorbent-type cloth that has been dampened with a very mild solution of liquid soap and lukewarm water.
 - C) **CABINET/BENCH:** Clean the cabinet portions of your Electone with a slightly dampened cloth containing a neutral cleaning agent. The cleaning agent selected should not contain a high wax content or any other substance that would have a tendency to form a "build-up" on the cabinet.
4. **Vinyl Products:** Do not set vinyl items, (i.e., headphones, vinyl doilies, etc.) on the finished surfaces of your Electone or use polyvinyl material to cover the unit for any extended period of time. A chemical reaction may occur between the finish chemical and those contained in the polyvinyl products, resulting in a permanent marring of the finish.

IMPORTANT NOTICE: This product has been tested and approved by independent safety testing laboratories in order that you may be sure that when it is properly installed and used in its normal and customary manner, all foreseeable risks have been eliminated. DO NOT modify this unit or commission others to do so unless specifically authorized by the manufacturer. Product performance and/or safety standards may be diminished. Claims filed under the expressed warranty terms may be denied if the unit is/has been modified. The warranty of title (patent infringement, etc.) will not be defended by the manufacturer in the area(s) that relate to the modification. Implied warranties may also be affected.

FCC INFORMATION (USA)

While the following statements are provided to comply with FCC Regulations in the United States, the corrective measures listed are applicable worldwide.

The digital series of Yamaha Electones™ use frequencies that appear in the radio frequency range, and if installed in the immediate proximity of some types of audio or video devices within three meters (approximately ten feet), interference may occur.

This series of Yamaha Electones™ has been type-tested and found to comply with the specifications set for a class B computer in accordance with those specifications listed in sub-part J, part 15 of the FCC rules. These rules are designed to provide a reasonable measure of protection against such interference. However, this does not guarantee that interference will not occur.

If your Electone™ should be suspected of causing interference with other electronic devices, verification can be made by turning your Electone™ off and on. If the interference continues when your Electone™ is off, the Electone™ is not the source of the interference. If your Electone™ does appear to be the source of the interference, you should try to correct the situation by using one or more of the following measures:

- Relocate either the Electone™ or the electronic device that is being affected by the interference.
- Utilize power outlets for the Electone™ and the device being affected that are on different branch (circuit breaker or fuse) circuits, or install AC line filters.
- In the case of radio-TV interference, relocate the antenna or if the antenna lead-in is 300 ohm ribbon lead, change the lead-in to coaxial type cable.

If these corrective measures do not produce satisfactory results, please contact an authorized Yamaha Electone™ dealer for suggestions and/or corrective measures. If you can not locate an authorized Yamaha Electone™ dealer in your general area, please contact the Electone™ Service Department, YAMAHA MUSIC CORP, U.S.A., 6600 Orangethorpe Ave., Buena Park, CA 90620.

If for any reason, you should need additional information relating to radio or TV interference, you may find a booklet prepared by the Federal Communications Commission Helpful: "How to Identify and Resolve Radio-TV Interference Problems." This booklet, Stock #004-000-00345-4, is available from the US Government Printing Office, Washington DC, 20402.

TROUBLESHOOTING

Please note that the appearance of any of the following phenomena does not indicate a mechanical failure of the Electone.

Phenomenon	Cause and Solution
A crackling sound is sometimes heard.	Noise may be produced when either an electrical appliance is turned ON/OFF or an electric power tool, such as a drill, is used in the proximity of the Electone. In such case, plug the Electone into an electrical outlet located as far as possible from the device that seems to be the source of the problem.
Interference from radio, TV, wireless radios, etc.	This is caused by the proximity of a high-power broadcasting station or amateur ham radio station.
Noise is produced in a radio, TV, etc.	Noise may be produced in such equipment if the Electone is located nearby. Use such equipment at a location as far as possible from the Electone.
The Electone sounds cause surrounding objects to resonate.	Because the Electone produces many sustained sounds, resonance may be caused in surrounding objects, such as cabinets or glass windows. If it becomes a problem, relocate the resonating objects or lower the Electone's volume.
The volume of the selected voice varies with the position played on the keyboard.	Because the intrinsic nature of electronic music instruments in general is to change timbre, it is extremely difficult to eliminate changes in the volume of a voice at different keyboard positions. This Electone is designed and adjusted to eliminate any performance-related problems. Its volume and timbre also vary widely according to the installation site and system configuration of the Electone, the position of the audience, etc.
The sound of the notes is broken or seems to include noise.	This effect occurs mainly with the voices of wind instruments, and is deliberately provided to recreate the characteristic sounds of the actual instruments. It provides instrument sounds with realistic features, such as reed vibration or the breath noises for BRASS.
Only one sound is heard when two notes are simultaneously played on either the pedal keyboard, or when a LEAD voice is used by itself.	For practical performance reasons, this Electone has been designed so that one note can be played at a time on the pedal keyboard or LEAD VOICES. If multiple keys are pressed only the highest note will be sounded (high-note priority). (See Pages 2-3)
Only seven notes are heard when eight notes are simultaneously played on the upper or lower keyboard.	A maximum of seven notes can be simultaneously sounded on the upper or lower keyboard. When AUTO BASS CHORD is in use, the maximum number of simultaneously sounded notes becomes six notes for the upper keyboard, or four notes for the lower keyboard. (See Pages 2-3)
Basic Registrations cannot be called to REGISTRATION MEMORY.	The MEMORY button was released after turning ON the POWER switch. To properly call the Basic Registrations, turn ON the POWER switch while pressing the MEMORY button, then continue depressing the MEMORY button for 1-2 seconds.
The Sustain or User Vibrato effect is not added even though its panel button is set to ON. (ME-55A/ME-35A)	With ME-55A/ME-35A, the way in which SUSTAIN and USER VIBRATO take effect must be set using the Multi Menu. If either is set to zero at the Multi Menu, its effect will not be applied. (See Pages 6, 17-18)
ARPEGGIO CHORD (ME-55A/ME-35A) or RHYTHMIC (ME-15A) is not produced even though its volume is set.	The rhythm was not started. Because ARPEGGIO CHORD or RHYTHMIC is synchronized with, and controlled by, the AUTO RHYTHM section, the rhythm must be ON for these features to operate. (See Page 5)
The pitch in SINGLE FINGER mode does not change, even when pressing the higher or lower keys of the keyboard.	SINGLE FINGER mode will only produce the notes within a fixed one-octave interval. If notes having the same letter-name are pressed anywhere on the lower keyboard, the chords that are sounded will share the same pitch. (See Page 10)
The harmony notes are not provided by MELODY ON CHORD even through the upper and lower keyboards are being played at the same.	The voice to be used for the harmony line has not been set. Choose a voice from UPPER ORCHESTRAL VOICES and set its volume. If the melody is played in the bass range of the upper keyboard, the harmony notes may not be sounded. (See Page 12)

Phenomenon	Cause and Solution
Some functions cannot be memorized in the REGISTRATION MEMORY.	The following functions cannot be memorized: START, SYNCHRO START, FILL IN, INTRO./ENDING switches of AUTO RHYTHM, and as well as certain Multi Menu functions, such as TRANSPOSITION. (See Page 13)
Inserting a new RAM Pack causes the ERROR lamp to light.	If an unformatted RAM Pack is inserted in the Electone, the Error lamp will flash several times. In that status, press the CONFIRM button to format the RAM Pack, then perform the TO PACK operation. (See Page 14)
A TO PACK operation is performed, but the ERROR lamp lights.	Check how the Pack was inserted as well as your To Pack operating procedure, then repeat the operation. Also, if the RAM Pack's Memory Protect switch is ON, data will not be transferred even if a TO PACK operation is performed. (See Page 14)
When a grey button is selected, a voice other than the displayed voice is produced.	This is because a VOICE MENU voice has been assigned to that grey button. To restore the original voice displayed on the control panel, either set the MENU ON button to OFF (ME-55A/ME-35A) or use the ORIGINAL VOICE button. (See Pages 5, 16)
A VOICE MENU voice cannot be assigned to a grey button.	With ME-55A/ME-35A, check that the MENU ON button is ON and review your operating procedure, then repeat the operation. With ME-15A, press the desired VOICE MENU button while pressing the initial grey button. (See Pages 4, 16)
The effect of SUSTAIN or USER VIBRATO has been set, but the desired effect is not produced. (ME-55A/ME-35A)	Check your operating procedure. When setting an effect, the panel's SUSTAIN or USER VIBRATO button must also be ON. (See Pages 17-18)
RECORD or EDIT mode cannot be entered, even after pressing the C.S.P. EDIT/CLEAR button.	A SONG button is ON. Set the SONG button to OFF then enter the RECORD or EDIT mode. (See Page 19)
Certain functions that were memorized in REGISTRATION MEMORY were not programmed into C.S.P. (ME-55A/ME-35A)	The rhythm's tempo or the AUTO BASS CHORD setting can be memorized to REGISTRATION MEMORY, but not to C.S.P. (See Page 19)
Chords, Fill In patterns or Intro/Ending patterns cannot be programmed to C.S.P. (ME-55A/ME-35A)	To program a chord, press a Duration button while pressing the proper keys on the lower keyboard. To program a Fill In or Intro/Ending pattern, press the REGIST. button while pressing the pertinent switch. After pressing INTRO and REGIST., be sure to program one chordless measure; after pressing ENDING and REGIST., be sure to program two measures with chords. (See Pages 19-20)
During C.S.P. programming, three warning beeps are sounded. (ME-55A/ME-35A)	When the memory capacity of a C.S.P. program is reached, three warning beeps are sounded to indicate that no further programming is possible. (See Page 19)
During C.S.P. playback, the accompaniment sounds are not produced. (ME-55A/ME-35A)	CHORD CANCEL is ON. If you wish to play back the accompaniment sounds, set CHORD CANCEL to OFF. (See Page 21)
After C.S.P. is played back, the previously registered Registrations in REGISTRATION MEMORY are no longer there. (ME-55A/ME-35A)	When a SONG button is set to ON for C.S.P. playback, the data of the REGISTRATION MEMORY during the original programming of C.S.P. replaces the current REGISTRATION MEMORY settings. If you wish to preserve the data of the current settings, first transfer it to a RAM Pack or Cassette Tape. (See Page 21)
The data added in C.S.P. EDIT mode was inserted prior to the desired position. (ME-55A/ME-35A)	To add Fill In or Intro/Ending data or data regarding the switching of Registrations, move the data pointer to the position after the position you actually wish to insert the data, then perform the programming operation. (See Page 24)
The FROM CASSETTE operation is performed, but data is not transferred to the Electone. (ME-55A/ME-35A)	Check the cord connection, operating procedure, the recorder's playback volume, type of cassette tape and recorder being used, etc., then repeat the FROM CASSETTE procedure. If the error reoccurs, replace the recorder. (See Page 25)
The control panel or related parts do not function normally or the memorized data changes in content.	Though a rare occurrence, electrical disturbances (such as that caused by lightning) may cause abnormal functioning of the Electone or changes in memorized data. In such cases, turn OFF the POWER switch, then turn it ON again while depressing the leftmost Multi Menu button (excluding the CASSETTE section). (ME-55A/ME-35A only)

SPECIFICATIONS

*Specifications subject to change without notice.

		ME-55A	ME-35A	ME-15A
KEYBOARDS		UPPER: 44KEYS (f-c4), LOWER: 44KEYS (F-c3), PEDALS: 13KEYS (C-c)		
UPPER ORCHESTRAL VOICES		STRINGS, BRASS 1, BRASS 2, COMBI. 1, COMBI. 2, COMBI. 3, VOLUME	STRINGS, BRASS, COMBI. 1, COMBI. 2, VOLUME	
UPPER LEAD VOICES		FLUTE, TROMBONE, TRUMPET, SAXOPHONE, VOLUME	OBOE, TRUMPET, VOLUME	
LOWER ORCHESTRAL VOICES		STRINGS, BRASS 1, COMBI. 1, COMBI. 2, VOLUME	STRINGS, COMBI., VOLUME	
BASS VOICES		ELECTRIC BASS, BASS, VOLUME		
ARPEGGIO CHORD / RHYTHMIC		ARPEGGIO CHORD: 1, 2, 3, 4, VOLUME	RHYTHMIC: 1, 2, VOLUME	
EFFECTS	SUSTAIN	UPPER ORCHES., LOWER ORCHES., PEDAL		
	USER VIBRATO	LEAD, UPPER ORCHES.	—	
	TREMOLO/SYMPHONIC	TREMOLO, SYMPHONIC, UPPER ORCHES., LOWER ORCHES.	—	
	GLIDE	GLIDE (FOOT SWITCH)	—	
AUTO RHYTHM PATTERNS		MARCH, TANGO, WALTZ 1, WALTZ 2, BALLAD, SWING, SAMBA, BOSSANOVA, LATIN ROCK, LATIN, BOUNCE, SLOW ROCK, 8 BEAT 1, 8 BEAT 2, DISCO, 16 BEAT	MARCH, TANGO, WALTZ, BALLAD, SWING, SAMBA, BOSSANOVA, LATIN ROCK, LATIN, BOUNCE, SLOW ROCK, 8 BEAT 1, 8 BEAT 2, DISCO, 16 BEAT	
	CONTROLS	VOLUME, TEMPO, TEMPO LAMP, START, SYNCHRO START, FILL IN, INTRO./ENDING, FILL IN VARI., EXTRA PERCUSSION	VOLUME, TEMPO, TEMPO LAMP, START, SYNCHRO START	
	FOOT SWITCH	RHYTHM STOP, FILL IN, ENDING	—	
AUTO BASS CHORD		SINGLE FINGER, FINGERED CHORD, CUSTOM A.B.C., MEMORY		
MELODY ON CHORD		1, 2, (1+2)	—	
REGISTRATION MEMORY		MEMORY, 1, 2, 3, 4, 5		
PACK		CONFIRM, FROM PACK, TO PACK, READY, ERROR		
C.S.P. PLAY		SONG 1, SONG 2		—
MULTI MENU	REGISTRATION MENU 1	1, 2, 3, 4, 5, 6, 7, 8		TROMBONE, SAXOPHONE, PIANO, JAZZ GUITAR, ACOUSTIC GUITAR, HARPISCHORD, PIPE ORGAN, ORIGINAL VOICE
	REGISTRATION MENU 2	9, 10, 11, 12, 13, 14, 15, 16		
	VOICE MENU 1	PIPE ORGAN, COSMIC BRASS 1, COSMIC BRASS 2, PIANO, ELECTRIC PIANO, HARPISCHORD, ORIGINAL VOICE, MENU ON		
	VOICE MENU 2	ACOUSTIC GUITAR, ELECTRIC GUITAR, JAZZ GUITAR, STEEL GUITAR, DISTORTION GUITAR, CLAVI, TIMPANI, WHISTLE		
	VOICE MENU 3	PAN FLUTE, CLARINET, FLÜGEL HORN, SAXOPHONE SAX, HARMONICA, COSMIC 1, COSMIC 2, CONTRA BASS		
	USER VIBRATO	U. LEAD = DELAY • DEPTH, U. ORCHES. DEPTH, 0, 1, 2, 3, 4		
	SUSTAIN	UPPER ORCHES., LOWER ORCHES., PEDAL, 0, 1, 2, 3, 4		
	C.S.P. RECORD	■, ←, →, REGIST./■, ■, ■, ■, ■, EDIT/CLEAR		
	C.S.P. PLAY MODE TRANSPOSITION	REPEAT, INTRO. COUNT, CHORD CANCEL, NORMAL, ↓, ↑		
CASSETTE	TO CASSETTE, FROM CASSETTE			
MAIN CONTROLS		MASTER VOLUME, EXPRESSION PEDAL, POWER, FOOT SWITCH (ME-55A only)		
ACCESSORY JACKS		HEADPHONES, AUX. OUT, EXP. IN, MIDI OUT, MIDI IN, TO CASSETTE (ME-55A/ME-35A only), FROM CASSETTE (ME-55A/ME-35A only), SPEAKER OUT, AC OUT		
AMPLIFIERS (RMS)		30 W + 15 W		
SPEAKERS		18 cm (7") × 1, 10 cm (4") × 2, 5 cm (2") × 1	18 cm (7") × 1, 10 cm (4") × 1, 5 cm (2") × 1	
DIMENSIONS (W × D × H)		106.2 × 39.2 × 84.6 cm (41 ⁴ / ₅ " × 15 ³ / ₇ " × 33 ² / ₇ ")		
WEIGHT		38 kg (83.8 lbs.)	37 kg (81.6 lbs.)	36 kg (79.4 lbs.)

HOW TO USE MIDI

MIDI is an abbreviation for Musical Instrument Digital Interface, and is a standard that allows various types of data to be exchanged between electronic musical instruments. You only have to connect the musical instrument you will be playing to another musical instrument (or to a digital device that is not a musical instrument) using a MIDI cable. After connection, when you play your musical instrument, data is sent to the other instrument which enables you to expand your musical range of expression.

The MIDI Function of ME Electones

What MIDI can do:

- **Transmission/recognition of Note On/Off data. (OMNI OFF, POLY mode)**
 - *Note information of the Upper Keyboard → 1 CH
 - *Note information of the Lower Keyboard → 2 CH
 - *Note information of the Pedal Keyboard → 3 CH
- **Transmission/recognition of control for Registration Memory and Registration Menu (ME-55A/ME-35A only).**
- **Transmission of MIDI clock (Internal Synchronous mode).**
- **Transmission/recognition of control for Rhythm Start/Stop.**
- **Transmission/recognition of control for Fill In (ME-55A/ME-35A only), Intro./Ending (ME-55A/ME-35A only) and Foot Switch (ME-55A only).**

Sample Applications

(1) ME → RX

The rhythmic patterns provided with the ME Electones are of very high quality, but if you would like to use rhythmic patterns which you have programmed yourself, try connecting the Digital Rhythm Programmer RX Series to ME.

The information (the common information that can be sent from ME as well as received by RX) that can be controlled with this sample connection is limited to rhythm-related information and consists basically of the following functions:

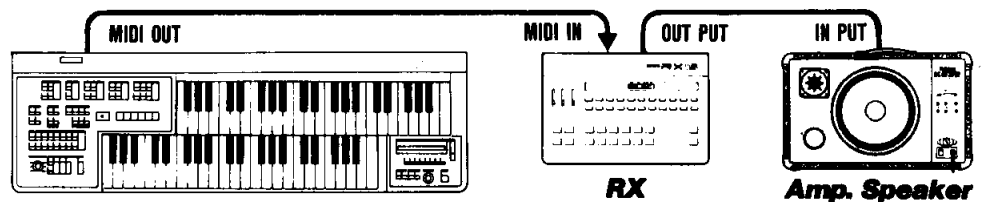

(1) Starting (or stopping) the rhythm of ME causes the rhythm of RX to start (or stop).

(2) Changing the tempo of ME changes the tempo of RX.

- * Set the Synchronization mode of RX to the External Synchronous mode. (For details, refer to the 'RX Owner's Guide'.)

(2) ME → DX

If you wish to enjoy playing the ME Electone by adding a voice you have created yourself to the ME Electone sound, then connect the ME Electone to the Digital Synthesizer DX Series. The information (the common information that can be sent from ME as well as received by DX) that can be controlled with this connection is basically as follows:

(1) Playing the Upper (Lower or Pedal) keyboard of ME also causes sound to be generated from DX.

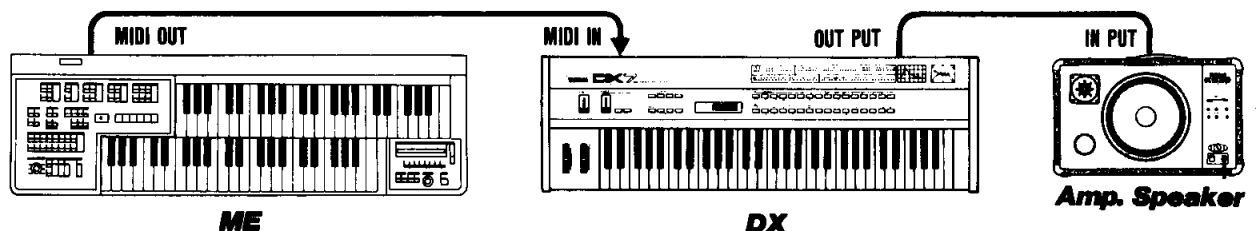

(2) Changing the Registration Memory or Registration Menu of ME also changes the voice of DX.

- * To select the keyboard which will be played to produce the DX sound, set the DX7 reception channel to one of the three channels. Set '1 CH' to receive the information of the ME Upper Keyboard, set '2 CH' for the Lower Keyboard and set '3 CH' for the Pedal Keyboard.

(3) ME ⇄ CX + YRM

If you wish to separately record the ME accompaniment, combine the sounds of the various keyboards, and then play back the total sound from ME without a loss in sound quality, please try connecting a model of the MSX Music Computer CX Series that is equipped with the Music Software YRM (MIDI RECORDER).

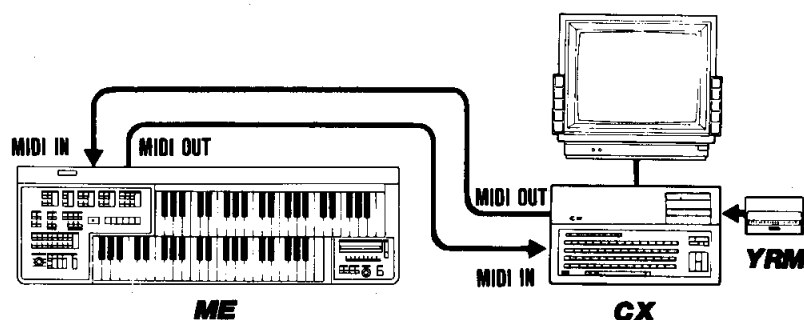

Controlling the MIDI Function

Switch to the External Synchronous mode (For recognition of MIDI clock).

- With ME-55A or ME-35A, first switch the POWER switch to OFF, then switch it back to ON while depressing the third button from the left of the MULTI MENU. After switching the POWER switch to ON, continuously depress the third button from the left for five seconds or more. Note that when you are performing this procedure, the MULTI MENU can display any page except CASSETTE & PACK.

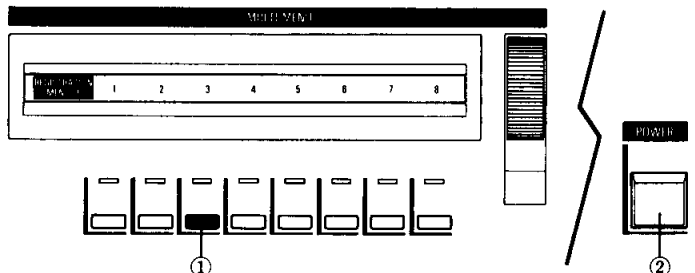

- With ME-15A, after switching the POWER switch to OFF as in the above case, switch it back to ON while depressing the SYNCHRO START button of AUTO RHYTHM, then continuously depress SYNCHRO START in that status for five seconds or more.

GLOSSARY FOR THE ME ELECTONES

(The numerals within parentheses indicate the page in this User's Guide where the term is discussed.)

A

ABC (Pg. 10)

The Electone abbreviation for the Auto Bass Chord feature.

ARPEGGIO CHORD (Pg. 5)

A feature that automatically produces either a strumming chord accompaniment synchronized with the rhythm or a melodious arpeggio accompaniment, by merely pressing the keys of the lower keyboard.

AUTO BASS CHORD (Pg. 10)

A feature that automatically produces a chordal accompaniment on the lower keyboard and a bass accompaniment on the pedal keyboard.

AUTO RHYTHM (Pg. 8)

This feature automatically produces a diversity of rhythm patterns using various percussion instruments.

AUX. OUT Jack (Pg. 26)

This jack is used to connect an external speaker, a cassette tape recorder, and so on.

AWM (Advanced Wave Memory)

A method of tone generation which memorizes the waveforms of actual musical instruments in the form of digital data. The rhythm sounds of the ME Electones are produced by an AWM Tone Generator.

B

BALLAD (Pg. 8)

This is a swing rhythm pattern with an added afterbeat, making it suitable for slow, pop ballads.

Basic Registration

Five Basic Registrations can be called to the Electone by turning ON the POWER switch while pressing the MEMORY button of REGISTRATION MEMORY.

BASS VOICES (Pg. 3)

This monophonic Voice section provides two BASS voices for use with the pedal keyboard.

BOUNCE (Pg. 8)

One of the typical jazz rhythms which are used in Big Band sounds, etc.

C

CASSETTE (Pg. 25)

A Multi Menu feature that lets you transfer the data memorized in the Electone to a Cassette Tape.

CHORD CANCEL (Pg. 21)

Setting this button to ON before C.S.P. playback will cancel the playback of the accompaniment by the lower and pedal keyboards. (The Fill In pattern and Registrations will be played back as programmed.)

CHORD SEQUENCE PROGRAMMER (Pg. 19)

This feature lets you preprogram a chord accompaniment sequence of a length equivalent to two songs, which also includes the Fill In patterns and the switching of Registrations.

CHORUS (Pg. 7)

This effect can be produced by setting both the TREMOLO and SYMPHONIC buttons to OFF.

COMBination (Pgs. 2-3)

In Electone terminology, COMBI refers to an organ voice that consists of a combination of different sounds.

CONFIRM (Pg. 14)

When using a RAM Pack, press this button together with the TO PACK or FROM PACK button.

COSMIC (Pgs. 4, 16)

This type of voice produces sounds that offer a variety of images (sounds that are mainly used by synthesizers), and is provided on the VOICE MENU.

C.S.P. (Pg. 19)

The abbreviation for the Chord Sequence Programmer.

CUSTOM A.B.C. (Pg. 11)

One of the buttons used to select the AUTO BASS CHORD mode. When this button is ON, the automatic accompaniment patterns of the lower and pedal keyboards become separate.

D

Data Pointer (Pg. 24)

This refers to the indicator used for the data positions during C.S.P. programming. During editing, this data pointer can be moved by the [] button, etc., in order to confirm the programmed data.

DELAY (Pg. 17)

For a User Vibrato effect added to LEAD VOICES, the DELAY button can be used to set the delay interval from the time the key is pressed until the Vibrato is applied.

DISCO (Pg. 8)

This rhythm pattern is good for disco music, and features a simple beat with a strong accent.

DISTORTION GUITAR (Pg. 16)

This voice is provided on the VOICE MENU, and resembles the sound of an electric guitar with distortion.

Duration Buttons [] (Pg. 19)

These buttons specify the length of chord data during C.S.P. programming. To program a chord, press a Duration button while pressing a chord on the lower keyboard.

E

EDIT/CLEAR (Pgs. 19,24)

This button is used while programming accompaniment to C.S.P. or editing the programmed data.

8-BEAT (Pg. 8)

A basic rock rhythm which is provided as two types of rhythm patterns.

End Button [] (Pg. 20)

To input the final cadence symbol at the end of a song during C.S.P. programming, press this button while pressing the Treble Clef button.

ENDING (Pg. 9)

If the INTRO./ENDING switch is pressed at the end of a song, a two-measure Ending rhythm pattern is produced then the rhythm is automatically stopped.

ERROR (Pg. 14)

When a RAM Pack in use does not operate properly, this lamp flashes for about 1 second.

EXP. IN Jack (Pg. 26)

The jack used for connecting an external musical instrument, such as a synthesizer or rhythm machine.

Expression Pedal

This pedal lets you control the volume while playing so you can express an enhanced intensity or softness through the notes you play.

EXTRA PERCUSSION (Pg. 9)

A feature that lets you add percussion instruments to the selected rhythm pattern.

F

FILL IN (Pg. 9)

A Fill In pattern is used to enhance the melody and other parts. By pressing the FILL IN switch of AUTO RHYTHM, the rhythm will be temporarily switched to a rhythm Fill In pattern.

FILL IN VARIATION (Pg. 9)

This button serves to provide variations of the Fill In patterns.

FINGERED CHORD (Pg. 11)

One of the buttons used to select the AUTO BASS CHORD mode. When this button is ON, pressing chords on the lower keyboard will automatically produce bass and chord accompaniments.

FLUGEL HORN (Pg. 16)

This voice is provided on the VOICE MENU, and offers the brass instrument sound of a trumpet with a soft reverberation.

FM (Frequency Modulation)

A method of tone generation which extracts the overtones from a sound then subjects the remaining sound to controlled frequency modulation by digital processing.

Foot Switch (Pgs. 7, 9)

A switch on the left side of the Expression Pedal. When pressed leftward, this switch can control the function set by the Foot Switch Selectors.

Foot Switch Selectors (Pgs. 7, 9)

These buttons set the Foot Switch to one of four functions: Rhythm STOP, Fill In, Ending, or Glide.

FROM CASSETTE (Pg. 25)

This button is used to recall data that was transferred to a Cassette Tape to the Electone.

FROM PACK (Pg. 14)

This button is used to recall data from a RAM Pack to the Electone

G

GLIDE (Pg. 7)

When using the Foot Switch, this effect lets you lower the pitch of the LEAD voice a half-step then gradually restore its original pitch.

Grey Button (Pgs. 4, 16)

Each voice section on the panel has one grey button, which can be used for assigning a voice from the VOICE MENU or selecting the displayed voice.

H

HARPSICHORD (Pgs. 4, 17)

This voice is provided on the VOICE MENU, and is a keyboard instrument that was popular during the 16th to 18th centuries (also called a Cembalo).

HEADPHONES Jack (Pg. 26)

An accessory jack on the front panel of the Electone that is used for connecting a headphones set.

I

INTRO (Pg. 9)

An introductory phrase to a song. On the Electone, it is a one-measure rhythm pattern that is automatically produced by setting the INTRO./ENDING switch to ON and starting the rhythm.

INTRO COUNT (Pg. 21)

When this button is set to ON before C.S.P. playback, a one-measure intro count (using a metronome sound) is produced before the playback is started.

L

LEAD VOICES (Pg. 2)

This Voice section provides a variety of monophonic voices to be played as the lead part on the upper keyboard.

Lower

Refers to the lower keyboard of the Electone.

M

Major Chord (Pg. 10)

Refers to a chord in the major scale, and is represented by letter-names such as C, F, etc. In SINGLE FINGER mode of AUTO BASS CHORD, a major chord is produced by simply pressing the root of a chord.

MASTER VOLUME

This knob controls the overall volume of the Electone.

MELODY ON CHORD (Pg. 12)

This feature automatically adds a harmony line while you play the melody line on the upper keyboard.

MEMORY (Pgs. 11, 13)

(1) The [M.] button of REGISTRATION MEMORY is used to memorize the control panel's current registration settings or to recall the Basic Registrations.

(2) The MEMORY button of AUTO BASS CHORD is used to repeat the accompaniment patterns together with the rhythm even after the lower (or pedal) keyboard keys have been released.

MENU ON (Pg. 16)

This button serves to select the VOICE MENU functions. When it is ON, the VOICE MENU voices that are assigned to grey buttons become valid (it must also be ON when assigning voices to grey buttons); when it is OFF, the voices displayed at the grey buttons become valid.

MIDI

Musical Instrument Digital Interface is a specification defining the exact manner in which digital data is transferred between electronic instruments and devices.

MIDI Jacks (Pgs. 26, 31)

These jacks are used to connect a synthesizer, rhythm machine, computer, etc. to exchange data between such devices and the Electone. Connect to MIDI OUT to transmit data, or to MIDI IN to receive data.

Minor Chord (Pg. 10)

Refers to a chord in the minor scale, and is represented as Am, Dm, etc. In SINGLE FINGER mode of AUTO BASS CHORD, a minor chord is produced by simultaneously pressing the root of a chord plus the next black key on its left.

Minor 7th Chord (Pg. 10)

Refers to a minor triad to which the minor 7th note has been added. In SINGLE FINGER mode of AUTO BASS CHORD, a minor 7th chord is produced by simultaneously pressing the root of a chord plus the next black and white keys on its left.

Monophonic

Capable of producing only one note at a time, even if multiple keys are pressed.

Multi Menu (Pgs. 15-25)

A rotating panel located to the right of the lower keyboard on ME-55A/ME-35A that offers various features, such as REGISTRATION MENU, VOICE MENUS, etc.

N

NORMAL (Pg. 18)

After the Electone's overall key has been transposed, the original key can be restored by pressing this button.

O

ORCHESTRAL VOICES (Pgs. 2-3)

This polyphonic Voice section has the voices of the major instruments of an orchestra, can simultaneously sound up to seven notes, and is provided for both the upper and lower keyboards.

ORIGINAL VOICE (Pgs. 4,16)

This button is used to cancel a specific VOICE MENU voice that has been assigned to a grey button and restore the original displayed voice.

P

PAN FLUTE (Pg. 16)

This voice, provided on the VOICE MENU, is reminiscent of a simple woodwind instrument with a pastoral mood.

Pedal

Refers to the pedal keyboard of the Electone.

Polyphonic

Capable of simultaneously producing multiple notes.

R

RAM Pack (Pg. 14)

This has a built-in LSI chip for data storage, so you can transfer the data memorized in the Electone to a RAM pack then recall that data from the RAM Pack to the Electone whenever you wish.

READY (Pg. 14)

When a RAM Pack is in use, the READY lamp lights up when the CONFIRM button is pressed, then flashes to indicate that data is being properly transferred.

Registration

In Electone terminology, it refers to a collection of settings for creating the total sound most suitable to the song to be played, including the voices, effects, rhythm, etc.

REGISTRATION Button (Pg. 20)

This button is pressed when programming a Fill In, Intro, or Ending pattern, or REGISTRATION MEMORY data to C.S.P.

REGISTRATION MENU (Pg. 15)

This Multi Menu feature is preset with 16 different registrations, any of which can be called by the touch of a single button.

REGISTRATION MEMORY (Pg. 13)

This feature lets you memorize the panel's current registration settings or call the Basic Registrations.

REPEAT (Pg. 21)

When this button is ON, the C.S.P. will perform playback repeatedly.

RHYTHMIC (Pg. 5)

When this button is ON, the voice of the LOWER ORCHESTRAL VOICES section is changed to be synchronized with the rhythm. (ME-15A)

Root (Pg. 10)

The root of a chord has the same letter-name as the chord itself. For example, the root of the C chord consisting of C, E, and G is the C note.

S

7th Chord (Pg. 10)

Refers to a major triad to which the 7th note has been added. In SINGLE FINGER mode of AUTO BASS CHORD, a 7th chord is produced by simultaneously pressing the root of a chord plus the next white key on its left.

SINGLE FINGER (Pg. 10)

One of the buttons used to select the AUTO BASS CHORD mode. When SINGLE FINGER is ON, chordal and bass accompaniments can be automatically produced by pressing the root of chords on the lower keyboard.

16-BEAT (Pg. 8)

A rhythm pattern based on 16th notes which is used in such musical genres as rock, fusion, and jazz.

SONG Button (Pg. 19)

C.S.P. is provided with two song buttons, each of which can be programmed with an accompaniment sequence. The SONG buttons are used for programming, playback or editing of accompaniment with C.S.P.

SUSTAIN (Pgs. 6, 18)

This effect adds an aftersound to voices after the keys are released. With ME-55A/ME-35A, the Sustain length can be set at the Multi Menu.

SWING (Pg. 8)

A standard rhythm pattern used in jazz music.

SYMPHONIC (Pg. 7)

This effect adds an expansive reverberation that resembles the combined playing of multiple instruments.

SYNCHRO START (Pg. 8)

When SYNCHRO START is ON, pressing any key of the lower keyboard will start the rhythm at the same time as the accompaniment.

T

TEMPO (Pg. 8)

This knob controls the speed of the rhythm.

TEMPO Lamp (Pg. 8)

This lamp indicates the speed of the rhythm, flashing at the first beat of each measure after the rhythm is started.

TO CASSETTE (Pg. 25)

This button is used to transfer the Electone's data to a Cassette Tape.

TO PACK (Pg. 14)

This button is used together with the MEMORY button of REGISTRATION MEMORY to transfer the Electone's data to a RAM Pack.

TRANSPOSITION (Pg. 18)

This Multi Menu feature lets you change the overall key of the Electone.

Treble Clef [] Button (Pgs. 19, 24)

This button is used at the start of C.S.P. programming or to program the final cadence symbol []. It can also be used to shift the data pointer immediately to the start or end of the song.

TREMOLO (Pg. 7)

This adds a rotating effect to a voice to produce a richly expansive sound.

U

Upper

Refers to the upper keyboard of the Electone.

USER VIBRATO (Pgs. 6, 17)

This feature allows you to add a vibrato that has been set according to your own preference. The effect of vibrato is set at the Multi Menu.

V

Vibrato (Pg. 6)

This effect vibrates the voices for added appeal. Each of the Electone voices has been preset with the most suitable Vibrato effect.

Voice

This is the generic term for each of the instrument sounds that can be produced by the Electone.

VOICE MENU (Pgs. 4, 16)

This feature allows one of a variety of voices to be assigned to the grey button of each Voice section. The VOICE MENUS of the Multi Menu of ME-55A/ME-35A contain 22 voices. With ME-15A, the 7 voices displayed below the rhythm patterns can be assigned.

Voice section

This refers to any section of the Electone's control panel at which voices can be selected, such as ORCHESTRAL VOICES, LEAD VOICES, and BASS VOICES.

Electone ME-15A

MIDI Implementation Chart / MIDI-Anwendungstabelle

Tableau d'implantation MIDI / Tabla de implementación de MIDI

Date: 8/15, 1987
Version: 1.0

Function...		Transmitted	Recognized	Remarks
Basic Channel	Default	1 2 3	1 2 3	UK (PRESET) LK (PRESET) PK (PRESET)
	Changes	×	16 ×	CONTROL (PRESET)
Mode	Default	Mode 3	Mode 3	
	Messages Altered	× *****	× ×	
Note Number		53-96 41-84 36-48	53-96 41-84 36-48	UK LK PK
	True Voice	*****	53-96, 41-84, 36-48	UK, LK, PK
Velocity	Note ON	× 9nH, v=64	× 9nH, v=1-127	
	Note OFF	× 9nH, v=0	× 9nH, v=0, 8nH	
After Touch	Key's	×	×	
	Ch's	×	×	
Pitch Bender		×	×	
Control Change		×	×	
Program Change		0-4	0-4	Regist. Memory
	True #	*****	0-4	
System Exclusive		×	×	
System Common	Song Pos	×	×	
	Song Sel	×	×	
	Tune	×	×	
System Real Time	Clock	○	○	*
	Commands	○	○	(FA, FC)
Aux Messages	Local ON/OFF	×	×	** (123)
	All Notes OFF	×	○	
	Active Sense	○	○	
	Reset	×	○	
Notes		* Recognize only when External Mode ** Recognize only channel 16		

Mode 1: OMNI ON, POLY
Mode 3: OMNI OFF, POLY

Mode 2: OMNI ON, MONO
Mode 4: OMNI OFF, MONO

○: Yes
×: No

MIDI Implementation Chart / MIDI-Anwendungstabelle

Tableau d'implantation MIDI / Tabla de implementación de MIDI

Date: 8/15, 1987

Version: 1.0

Function...		Transmitted	Recognized	Remarks
Basic Channel	Default	1 2 3	1 2 3 16	UK (PRESET) LK (PRESET) PK (PRESET) CONTROL (PRESET)
	Changes	×	×	
Mode	Default	Mode 3	Mode 3	
	Messages Altered	× *****	× ×	
Note Number		53-96 41-84 36-48	36-96 36-96 36-96	UK LK PK
	True Voice	*****	36-96	UK, LK, PK
Velocity	Note ON	× 9nH, v = 64	× 9nH, v = 1-127	
	Note OFF	× 9nH, v = 0	× 9nH, v = 0, 8nH	
After Touch	Key's	×	×	
	Ch's	×	×	
Pitch Bender		×	×	
Control Change		×	×	
Program Change		0-4, 32-47	0-4, 32-47	Regist. Memory & Regist. Menu
	True #	*****	0-4, 32-47	
System Exclusive		○	○	FILL SW INTRO./ENDING SW FOOT SW
System Common	Song Pos	×	×	
	Song Sel	×	×	
	Tune	×	×	
System Real Time	Clock	○	○	* (FA, FC)
	Commands	○	○	
Aux Messages	Local ON/OFF	×	×	** (123)
	All Notes OFF	×	○	
	Active Sense	○	○	
	Reset	×	○	
Notes		* Recognize only when External Mode ** Recognize only channel 16		

Mode 1: OMNI ON, POLY
Mode 3: OMNI OFF, POLY

Mode 2: OMNI ON, MONO
Mode 4: OMNI OFF, MONO

○: Yes
×: No

SINCE 1887



YAMAHA

YAMAHA CORPORATION, HAMAMATSU, JAPAN