

CP35

electronic piano operating manual



INTRODUCTION

Thank you for choosing a Yamaha CP35 Electronic Piano.

The CP35's advanced keyboard lets you vary independent note volume according to key attack (velocity) giving you touch response strikingly similar to that of an acoustic piano. Moreover, with two independent sound channels each featuring four filter selectors, and a total of four preset sound selectors, you have a vast array of sounds available to perfectly match the mood of your music.

Each sound channel also offers pitch, waveform and decay controls that add even greater versatility. Other features include tremolo controls, a built-in flanger and sustain pedal capability.

Whatever type of music you play--from jazz to baroque--the CP35 electronic piano gives you all the sound, versatility and response you need.

In order to make full use of the CP35's extensive capabilities, be sure to read this manual thoroughly.

WARNING: TO REDUCE THE RISK OF FIRE OR ELECTRIC SHOCK, DO NOT EXPOSE THIS APPLIANCE TO RAIN OR MOISTURE. THERE ARE NO USER-SERVICEABLE PARTS INSIDE. REFER SERVICING TO A QUALIFIED SERVICE PERSONNEL.

CONTENTS

| | |
|--|---|
| CAUTION: READ THIS FIRST | 2 |
| SETUP | 3 |
| FRONT PANEL AND CONTROLS | 4 |
| SIDE PANEL REAR PANEL AND CONTROLS | 6 |
| CONNECTION DIAGRAM | 7 |
| SPECIFICATIONS | 8 |
| BLOCK DIAGRAM | 9 |

CAUTION : READ THIS FIRST

[INSTALLATION/LOCATION]



Do not use this unit in any of the locations mentioned below, as this may impair the sound quality or result in failure or breakdown.

- * Location near a window where the unit may be exposed to direct sunlight or other extremely hot locations.
- * Locations with a particularly low temperature.
- * Locations exposed to high levels of moisture or dust.
- * Locations susceptible to vibration.

[DO NOT USE FORCE]



Do not force when using the switches or knobs.

[TAKE CARE OF THE POWER CORD]

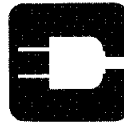

In order to prevent cord breakage and shortcircuits, take hold of the plug, not the actual cord, when disconnecting it from the power outlet. If the unit is not to be used for prolonged periods of time, disconnect the plug from the power outlet.

[MOVING THE UNIT]



Make sure that you disconnect the power cord and detach connecting cables to other equipment before moving the unit.

[CONNECTING AND DISCONNECTING OUTPUT CORDS]



If the output cords are connected or disconnected when the volume level of the amplifier should always be set with care, as the application of excessive input to the amplifier may cause damage to the amplifier or speakers. Before connecting or disconnecting the output cords to the other equipments, make sure to switch off each power switch.

[MAINTAINING THE UNIT]



Do not wipe the unit with benzine or thinner, and do not use aerosol sprays in its vicinity. Always use a soft cloth to wipe the unit.

[KEEP THIS MANUAL]



Keep this manual in a safe place for future reference, and refer to it frequently until you are fully familiar with your CP35.

[THUNDER STORMS]



Remember to disconnect the power plug from the power outlet whenever there is a thunderstorm in order to prevent accidents resulting from lightning.

[OTHER APPLIANCES]



Since your CP35 incorporates a considerable amount of digital circuitry, it is advisable to use it where it will not be influenced by electromagnetic radiation from appliances such as televisions, radios, etc.

SETUP

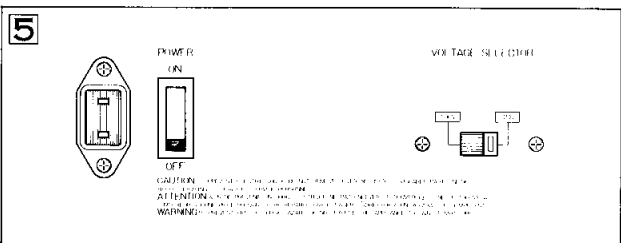
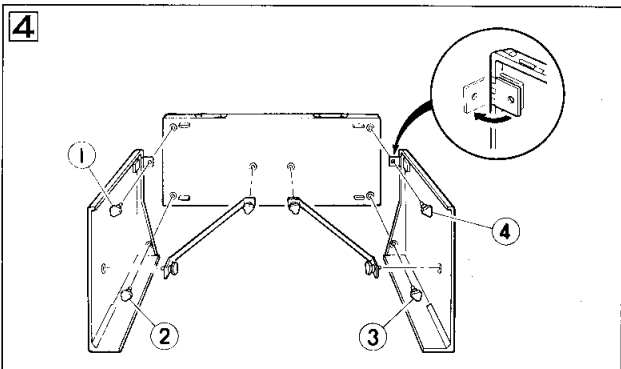
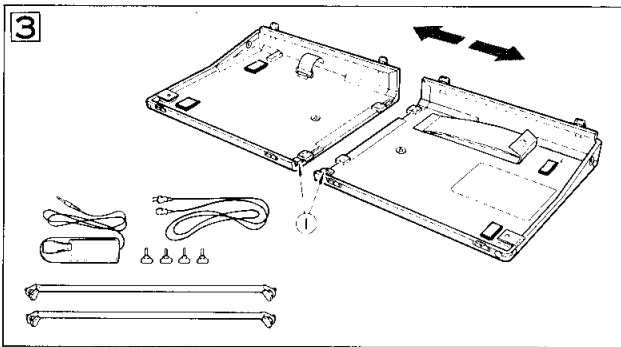
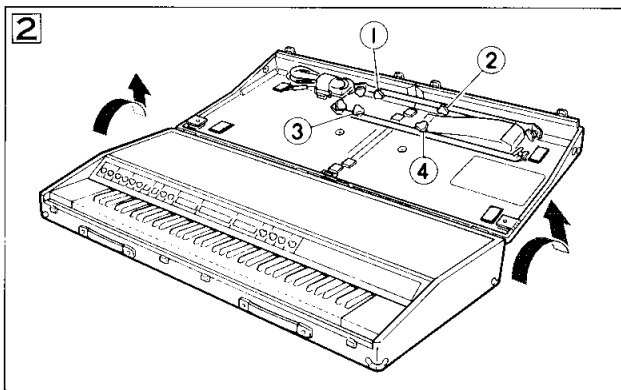
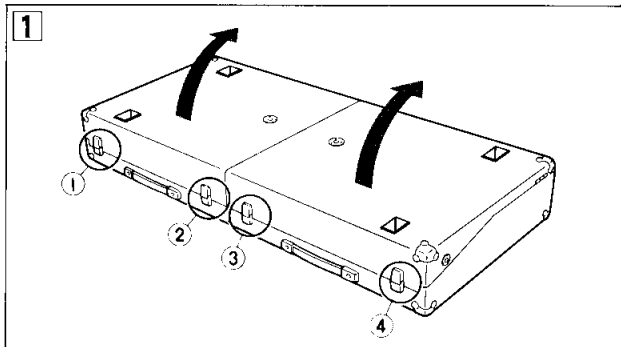

(U.S. & CANADIAN MODELS)

- Lay the CP35 on the floor as shown and open the lid fully by unlatching the four catches ① ~ ④ .

- Detach the lid from the body by lifting it so as to slip it off its rear hinges.
Provided inside of the lid are the AC cord, leg braces and the sustain pedal.
- Unscrew the thumbscrews ① ~ ④ and remove the leg braces.
NOTE: Make sure not to lose these thumbscrews, for they will be used when connecting the main body and legs.

- Unlatch the catch ① found inside of the lid and pull the lid apart right and left.
NOTE: The two halves of the lid become the CP35's legs.

- Place the main body of the CP35 on its back edge and fasten one leg to each side of the body using two of the thumbscrews removed in step 2.
- Fix the main body and the legs securely with the leg braces.
- Set the CP35 upright and check each thumbscrew for tightness. This completes the physical assembly of the CP35.
- Connect both the output cord to the amplifier and the sustain pedal.

- Set the voltage selector to the proper line voltage of that area where CP35 is used and set the switches and controls. And then connect the AC cable to the AC INLET jack on the CP35 firmly.
(→ SEE PAGE 6 & 7)

FRONT PANEL AND CONTROLS

CONTROL PANEL (FRONT PANEL)

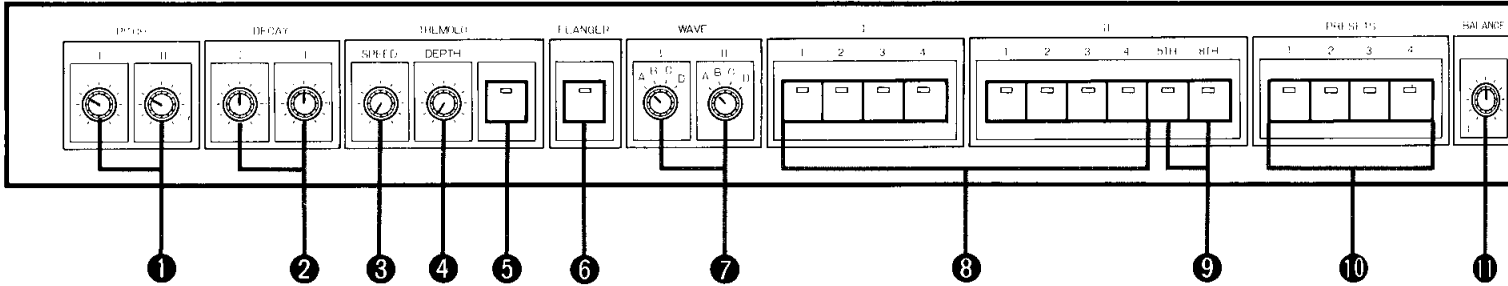

1 PITCH I, II

The PITCH I and PITCH II controls independently adjust the pitch of the CP35's sound channels I and II, respectively. Turning either of these controls to the right (clockwise) raises the pitch of the respective channel, while turning to the left (counterclockwise) lowers pitch.

Setting channel I and channel II to different pitches produces a "detune" effect creating a fatter, honky-tonk piano type sound.

Pitch control range is approximately from 436Hz to 453Hz. Setting the PITCH controls to approximately 10 o'clock provides 440Hz (A₃) tuning.

2 DECAY I, II

The DECAY I and DECAY II controls independently adjust the decay time of sound channels I and II, respectively. Turning either of these controls to the right (clockwise) lengthens the decay time of the respective channel, while turning to the left (counterclockwise) shortens decay time. The DECAY controls can each be set to eight different positions. Once the pitch, tone and balance of the two sound channels have been set, the DECAY I and II controls can be used to create a broad variety of decay time combinations providing extra sound control flexibility.

By setting exceptionally long decay times it is possible to create sustained, organ-like tones.

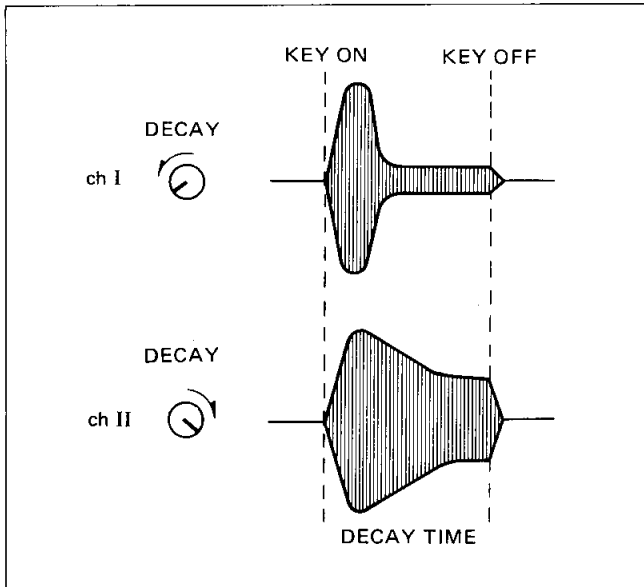

3 TREMOLO SPEED

The tremolo effect produces periodic variations in the volume of the sound. Turning the TREMOLO SPEED control to the right (clockwise) increases the speed of the volume variation, while turning it to the left (counterclockwise) creates a slower tremolo sound.

If the CP35's independent OUT 1 and OUT 2 outputs are connected to separate amplifier and speaker systems, the sound will seem to sweep back and forth between the two speakers at a rate determined by the TREMOLO SPEED control.

4 TREMOLO DEPTH

This control determines by how much the volume of the sound is varied by the tremolo effect. Turning the TREMOLO DEPTH control to the right (clockwise) produces a larger variation in volume, while turning it to the left (counterclockwise) produces a smaller (shallower) volume variation.

| TREMOLO SPEED | TREMOLO DEPTH | TREMOLO OUTPUT |
|--------------------------|-----------------------------|----------------|
| <p>SPEED</p> <p>Slow</p> | <p>DEPTH</p> <p>Smaller</p> | <p>OUT 1</p> |
| <p>SPEED</p> <p>Fast</p> | <p>DEPTH</p> <p>Larger</p> | <p>OUT 2</p> |

5 TREMOLO SWITCH

This switch turns the tremolo effect on or off. Pressing this switch causes its LED indicator to light showing that the tremolo effect is on. Pressing it a second time turns the tremolo effect off (LED "off").

* Tremolo output from OUT 1 and 2 is reverse phase.

* If both of the tremolo outputs from OUT 1 and OUT 2 are mixed with the monaural signal by using a mixer, the tremolo effect is not produced.

6 FLANGER SWITCH

The flanger effect produces a pleasant "swooshing" or "swirling" effect with long tones, and adds interesting tonal variation to staccato passages.

Pressing the FLANGER switch causes its LED indicator to light showing that the flanger effect is on. Pressing it a second time turns the flanger effect off (LED "off").

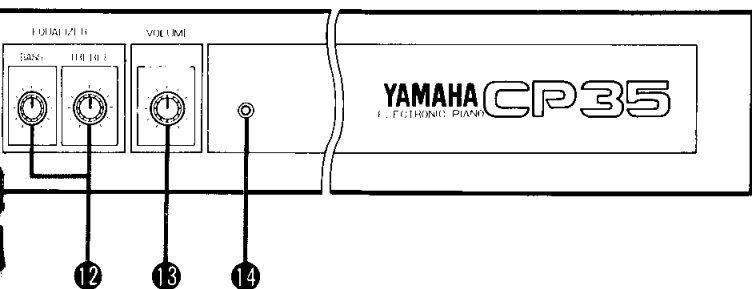

7 WAVE I, II

The WAVE I and II selectors independently select the waveform shape of the channel I and channel II tone generators, respectively. Four different basic waveforms (A, B, C and D) can be selected for each channel, providing a broad range of subtle tonal variations.

*The WAVE selectors are only effective when the PRESETS selectors 10 are not in use.

8 FILTER I, II SELECTORS

These selectors determine the tonal quality of the sound. An independent set of four FILTER selectors is provided for each sound channel. Pressing any FILTER selector causes its LED indicator to light showing that the respective filter is activated.

1. FILTER SELECTOR 1 activates a low-pass filter thereby producing a round, warm sound. Effect is the same for channel I and channel II.
2. FILTER SELECTOR 2 activates a low-pass filter with a higher cutoff frequency than that of FILTER SELECTOR 1, thereby producing a somewhat harder sound. The channel I FILTER 2 selector adds an attack to the sound, while the channel II FILTER 2 selector does not.
3. FILTER SELECTOR 3 activates a bandpass filter which produces a clear, well-defined sound. Effect is the same for channel I and channel II.
4. FILTER SELECTOR 4 activates a high-pass filter thereby producing a hard, bright sound. The channel I FILTER 4 selector adds an attack to the sound, while the channel II FILTER 4 selector does not.

*FILTER selectors 1 through 4 (channels I and II) are only effective when the PRESETS selectors 10 are not in use. When any of the PRESETS sounds are in use, filter settings are held in "standby", and the selected filter LED's flash to indicate the standby mode. Changing filter settings while any PRESETS selector is in use causes no change in sound quality.

9 5TH, 8TH SELECTORS

These selectors raise the pitch of channel II by the designated interval with respect to channel I.

Pressing the 5th selector causes the pitch of channel II to be an interval of perfect fifth higher than channel I.

Pressing the 8th selector causes the pitch of channel II to be one octave higher than channel I.

Pressing both the 5th and 8th selectors causes the pitch of channel II to be an interval of perfect 12th (an octave and a fifth) higher than channel I.

*The 5th and 8th selectors are only effective when the PRESETS selectors 10 are not in use. When any of the PRESETS sounds are in use, 8th and 5th selector settings are held in "standby", and the selected interval LED(s) flash to indicate the standby mode.

10 PRESETS

Four preset sound selectors are provided, only one of which can be used at a time.

PRESETS have priority over the FILTER selectors, so pressing and PRESETS selector, even while the FILTER selectors are in use, immediately switches to the PRESETS sound.

1. Immediate switching from the FILTER sound to the PRESETS sound is accomplished simply by pressing the desired PRESETS selector. When a PRESETS selector is pressed, active FILTER settings are held in "standby" with their respective LED indicators flashing.
2. The PRESETS sounds consist of pre-programmed channel I and II WAVE, FILTER, BALANCE, and channel II 5th and 8th selector settings.
3. Controls which do affect the sound when the PRESETS are in use are PITCH, DECAY, TREMOLO, FLANGER, EQUALIZER and VOLUME.
4. FILTER settings can be selected or altered while the PRESETS are in use without immediately affecting the sound. FILTER settings selected in this way are indicated by the appropriate FILTER indicator LED(s) flashing.

WAVE and BALANCE settings can also be altered in advance while the PRESETS are in use.

5. Immediate switching from the PRESETS sound to the FILTER sound is accomplished by pressing the activated PRESETS selector (lighted LED) a second time.

*PRESETS selectors, PRESETS selector and FILTER selector settings cannot be combined.

In addition to the combination of FILTER I 1-4 and FILTER II 1-4, using channel I and II DECAY WAVE allows you to adjust the timbre at will. Be sure to take advantage of the sound creation possibilities of DECAY I and II.

11 BALANCE

Determines the relative volumes of channels I and II--i.e. "mixing" between channels I and II. Turning the BALANCE control to the right (clockwise) increases the volume of channel II in relation to channel I, while turning it to the left (counterclockwise) increases the volume of channel I in relation to channel II.

*The BALANCE control is only effective when the PRESETS selectors 10 are not in use.

12 EQUALIZER

BASS: Turning the BASS control to the right (clockwise) emphasizes the low-frequency range thereby producing a fat, heavy sound. Turning this control to the left (counterclockwise) de-emphasizes the low-frequency range, while, set to its center position response is virtually flat.

TREBLE: Turning the TREBLE control to the right (clockwise) emphasizes the high-frequency range thereby producing a light, bright sound. Turning this control to the left (counterclockwise) de-emphasizes the high-frequency range, while, at its center position response is virtually flat.

13 VOLUME

Controls the overall volume level of the CP35 sound. Turning the VOLUME control to the right (clockwise) increases overall volume, while turning it to the left (counterclockwise) decreases overall volume.

14 POWER INDICATOR

This indicator lights to show that the rear-panel power switch is turned on.

SIDE PANEL • REAR PANEL AND CONTROLS

SIDE PANEL

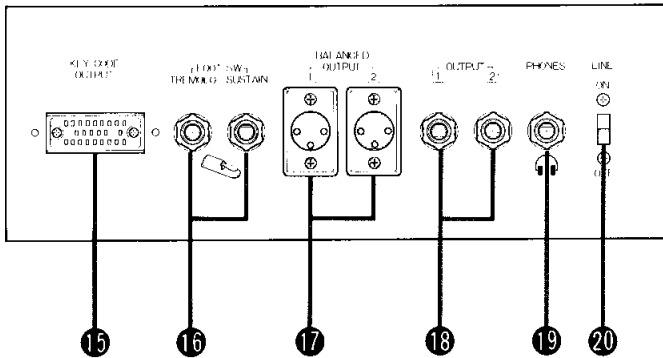

15 KEYCODE OUTPUT

This multi-pin terminal can be connected to the Yamaha CS70M Dual Channel Polyphonic Synthesizer KEYCODE INPUT connector with a keyboard cable (KC-1, option), permitting the CS70M to be played from the CP35 keyboard.

16 FOOT SW

TREMOLO: A foot switch (FC-4, contained as accessory) plugged into this jack can be used to turn the TREMOLO effect on and off. The effect of the foot switch is the same as that of the front-panel TREMOLO switch.

* TREMOLO can be turned on or off using the footswitch even if the front-panel TREMOLO switch is off.

SUSTAIN: A foot switch (FC-4, contained as accessory) plugged into this jack permits foot on/off control of CP35 sustain. Sustain length is determined by the front-panel DECAY I and II controls.

FC-4, one unit is contained in product as accessory. More foot switches (FC-4 or FC-5) are available optionally.

17 BALANCED OUTPUT 1, 2

Balanced output connectors for channels 1 and 2. These three-pin balanced XLR-TYPE output connectors should be used in cases where long cable runs are necessary in order to reduce hum and noise pickup. When the TREMOLO effect is activated, the volume variation output from channel 2 is reverse phase from that of channel 1. When the TREMOLO effect is not activated, output from channel 1 and channel 2 is identical.

18 OUTPUT 1, 2 (unbalanced)

These standard phone plug outputs should be used when connecting the CP35 to conventional musical instrument amplifiers. When the TREMOLO effect is activated, the volume variation output from channel 2 is reverse phase from that of channel 1. When the TREMOLO effect is not activated, output from channel 1 and channel 2 is identical.

REAR PANEL

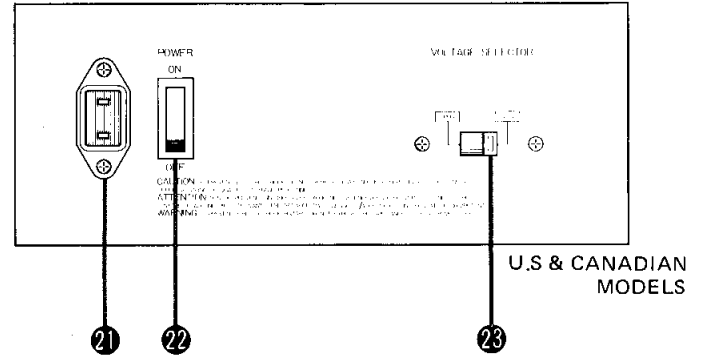

19 PHONES

Plugging a pair of stereo or mono headphones into this jack provides convenient private monitoring of the CP35 output. Headphone volume is controlled by the main VOLUME control 13.

20 LINE ON/OFF

This switch turns signal output from the BALANCED OUTPUT 17 and OUTPUT 18 connectors on or off. The PHONES output remains active even if the LINE switch is turned OFF.

21 AC CORD CONNECTOR

Accepts the female-connector end of the supplied AC power cord.

22 POWER ON/OFF

This switch turns AC power to the unit on or off. When the POWER switch is initially turned on, the front-panel power indicator, and PRESETS 1 indicator light, and the FILTER I-1, II-3 indicators flash indicating standby. Playing the keyboard produces the PRESETS 1 sound.

23 VOLTAGE SELECTOR

This selector must be set to comply with the AC main voltage in your area. Improper VOLTAGE SELECTOR setting can result in impaired performance and even cause permanent damage to the instrument.

<U.S. & CANADIAN MODELS>

The voltage changover switch is factory-set to AC 120V. Confirm the switch is set as shown in the figure on the left, and don't touch it.

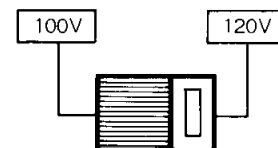

CONNECTION DIAGRAM

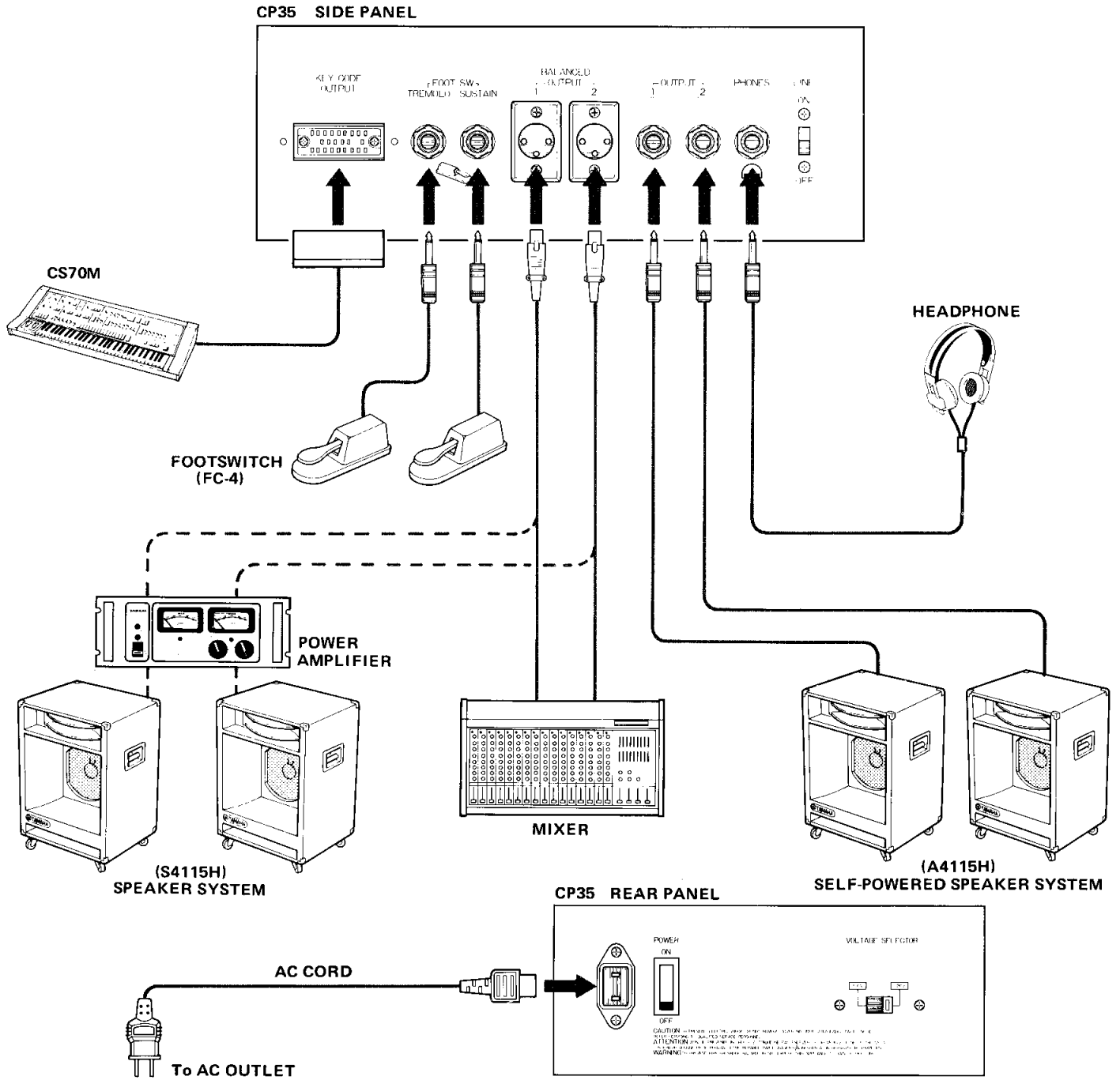

(GENERAL MODEL)

The line voltage selector on the rear panel selects one of four regulating positions for each nominal line voltage. To select the correct nominal line voltage and selector position, refer to Table 1. In order to set the voltage selector, each position is shown in Fig. 1.

| If voltage in your area is: | 108 - 132 volts | 198 - 242 volts | 216 - 264 volts |
|-----------------------------|-----------------|-----------------|-----------------|
| Set voltage selector to: | 120V | 220V | 240V |

Table 1

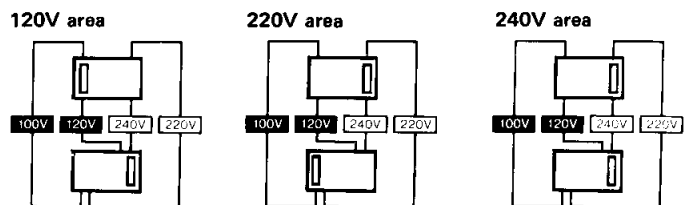

Fig. 1

CAUTION: THIS EQUIPMENT MAY BE DAMAGED IF OPERATED WITH THE LINE VOLTAGE SELECTOR SET TO AN INCORRECT POSITION.

SPECIFICATIONS

KEYBOARD 73 keys (E0 - E6)
 Velocity-sensitive touch response
 16 note simultaneous output,
 max.

CONTROLS
 PITCH I
 PITCH II
 DECAY I 8 position switch
 DECAY II 8 position switch
 TREMOLO SPEED
 TREMOLO DEPTH
 TREMOLO ON/OFF
 FLANGER ON/OFF
 WAVE I 4 position switch (A,B,C,D)
 WAVE II 4 position switch (A,B,C,D)
 FILTER I 4 independent selectors
 (1,2,3,4)
 FILTER II 4 independent selectors
 (1,2,3,4)
 5TH, 8TH Independent 5th and 8th
 transpose selectors
 PRESETS 4 independent selectors
 (1,2,3,4)
 BALANCE I ↔ II
 EQUALIZER Continuously variable bass and
 treble controls
 VOLUME

REAR PANEL
 KEY CODE OUTPUT
 FOOT SW TREMOLO
 FOOT SW SUSTAIN
 BALANCED XLR type connectors
 OUTPUT ① ②
 UNBALANCED 1/4" phone jacks
 OUTPUT ① ②
 PHONES 8 ohms or high impedance
 headphones
 LINE ON/OFF
 POWER REQUIRE- U.S. & Canadian models
 MENTS 120V 50/60Hz 36 Watts
 General model
 Selectable (110, 120, 220 or
 240V) 36 Watts
DIMENSIONS 50-1/4" x 31-1/4" x 23-1/2"
 (W x H x D) (1,276 x 794 x 596 mm)
WEIGHT 110.2 lbs (50 kg)
STANDARD FC-4 footswitch
ACCESSORY

** Specifications are subject to change without notice.*

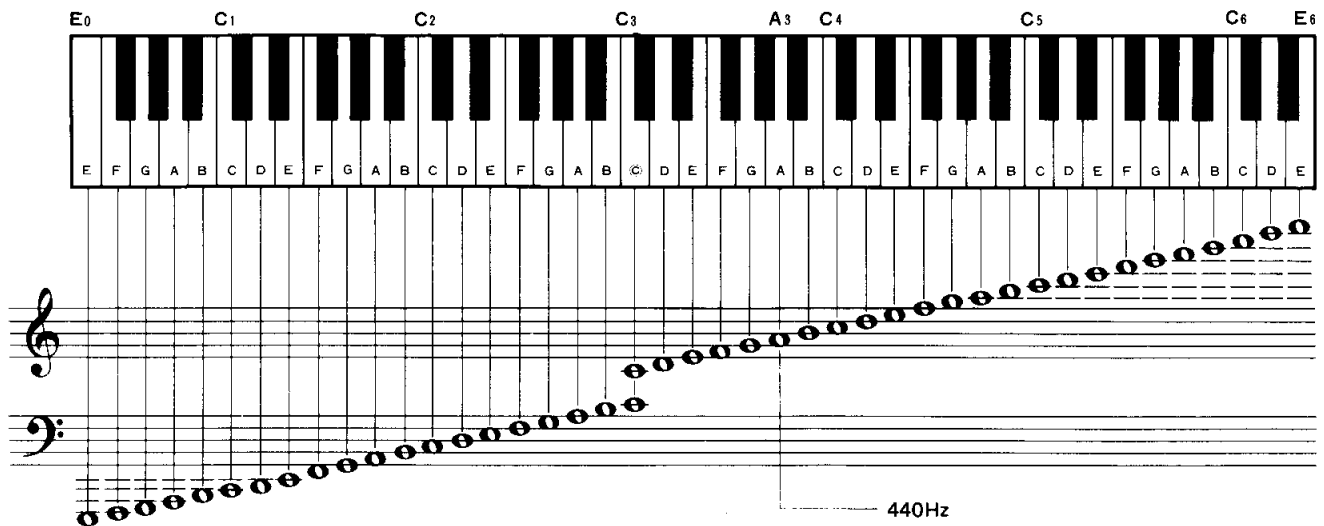

BLOCK DIAGRAM

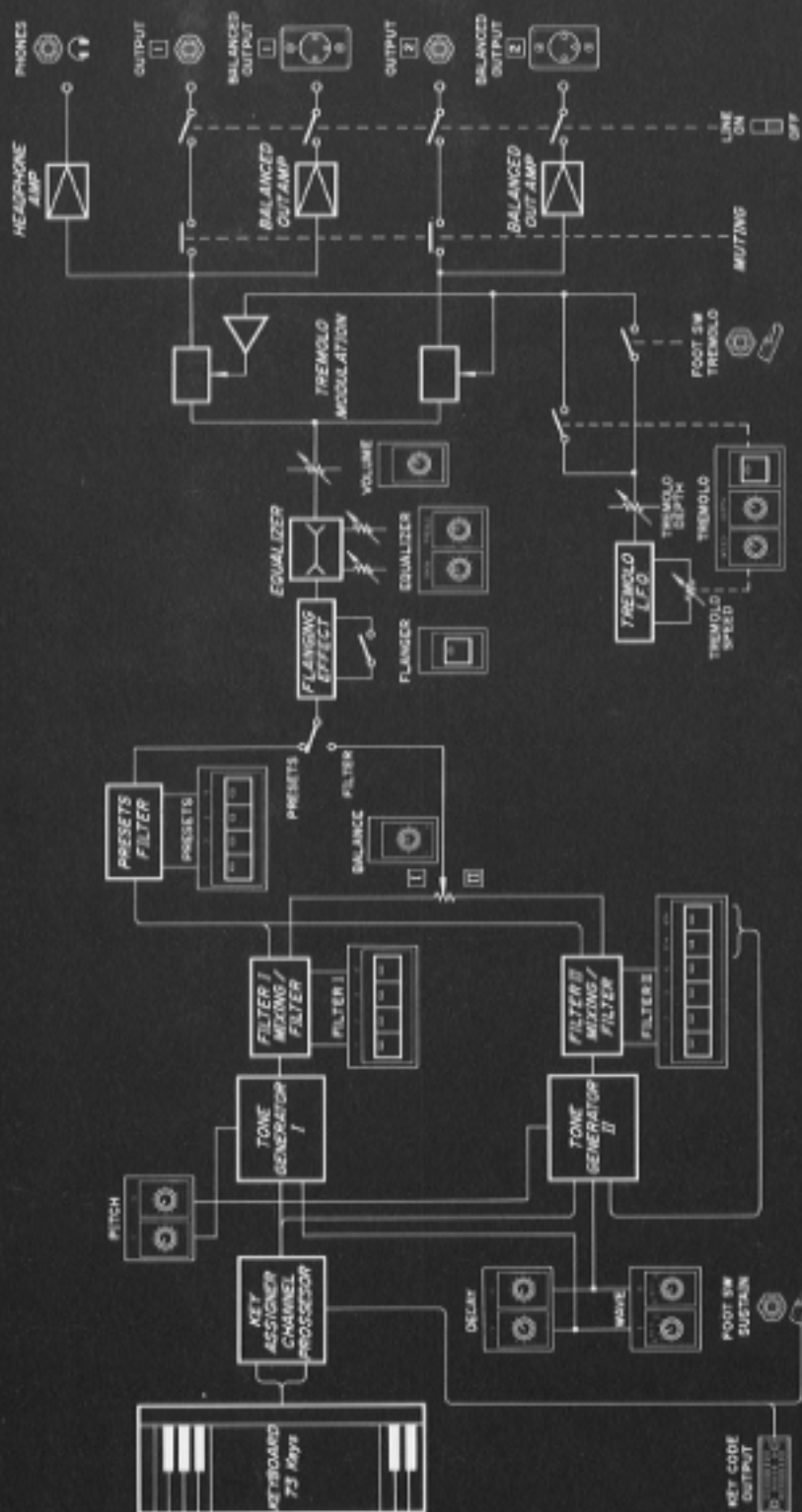

SERVICE

The CP35 are supported by Yamaha's worldwide network of factory trained and qualified dealer service personnel. In the event of a problem, contact your nearest Yamaha dealer.

SINCE 1887  **YAMAHA**
NIPPON GAKKI CO., LTD. HAMAMATSU, JAPAN