

A White Paper
Of
The Installation Series Loudspeakers

YAMAHA CORPORATION
PA·DMI Division,
Advanced System Development Center

1 Introduction

The ease with which a speaker system can be adjusted to match the characteristics of a facility is of the utmost importance to sound contractors and engineers. In the same way that a painter's canvas must be white in order to show the true colors of his paints, a speaker system must be a "white canvas" in the sense that it accurately reproduces the waveforms provided as input and responds in a linear fashion to equalization – in audio terms it needs to provide a "flat response". The two most common causes of such uneven response are "comb filter" caused by the installation or architectural condition and "difference between the phase characteristics of the speakers". The former must be considered in the aspect of the system design such as speaker angle, etc. The latter should be considered as the important matter for making the Yamaha speaker system as "white canvas".

<Figure 1: Speaker measurement condition>

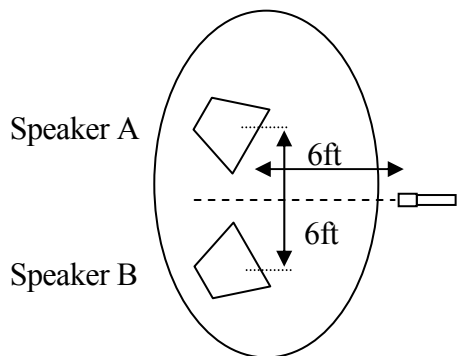

We made the simple test for measuring the phase characteristics using two 2-way speaker systems. Figure 1 shows the setting. Speaker system A has 60 degrees x 40 degrees (horizontal x vertical) of the high frequency directivity, while speaker system B has 90 x 50. The amplitude response is almost the same. When driving both speaker systems that have the same phase characteristics simultaneously, the relative S.P.L. increases by 6dB at all frequencies, as shown in Figure 2. We then changed the phase characteristics of speaker system B and made measurement. The result is shown in Figure 3. In the frequency range where the phase difference is more than 120 degrees, significant cancellation is observed in the amplitude response (you can see the cancellation in the range where the phase difference is between 120 and 240 degrees). In the frequency range where cancellation is observed, the equalizer does not respond in linear so it is very difficult to improve the frequency characteristics using the equalizer.

<Figure 2: Driving two speaker systems that have the same phase characteristics>

Amplitude

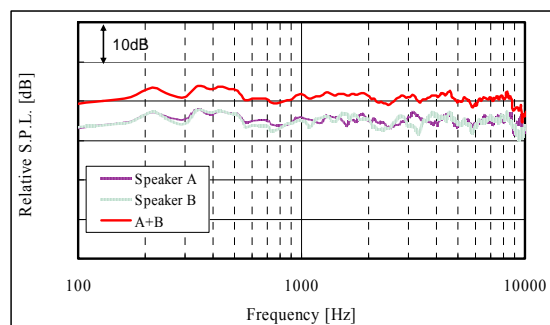

Phase

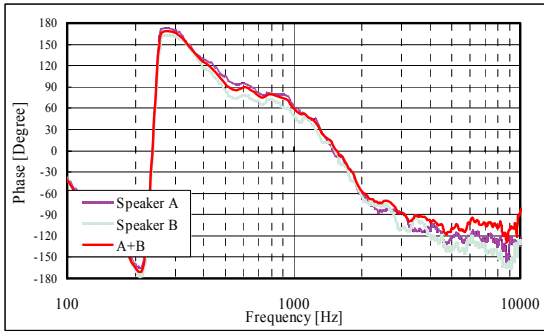

<Figure 3: Driving two speaker systems that have different phase characteristics>

Amplitude

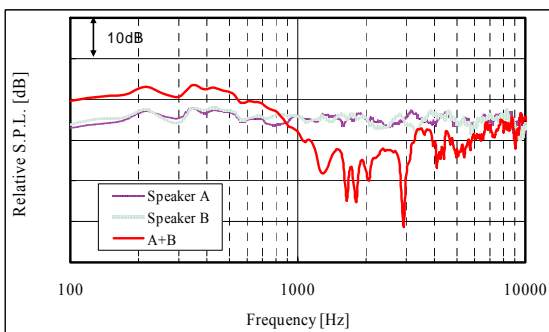

Phase

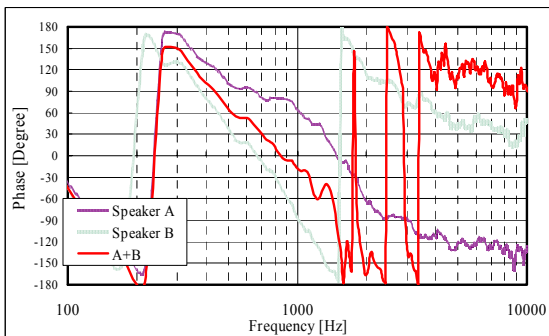

This problem happens not only between the same speaker models but also between the different speaker models.

For example, in a live concert, it is common to make speaker arrays using the multiple same speaker systems. However, in a facility, it is common to use different speaker models together.

Yamaha thought that "even if different speaker models are used in a system, we should offer a "white canvas" and paid attention to the phase characteristics, aiming for the unification of the phase characteristics through the series. As for sound quality, we aimed for both the clearness of speech (PA) and the high-fidelity sound reinforcement of vocals/musical instruments, while the unification of the tone color (Family Sound Concept) of all products in the series was the basic concept.

Also, we made a great effort to reproduce the natural dimensions of the sound image. In other words, the size of image must be an accurate representation of the source, particularly with regard to speech. In short, the design concept of the "Installation" series is to realize the concepts for the phase characteristics and tone color.

The following explains the details of our concept, as well as how to realize the concept.

2 Consideration of speaker phase characteristics

In a design of "the installation series", we investigated the influences of phase characteristics of speakers into their responses at receiving points at first.

1) About phase characteristics between drivers

Even a single speaker system may have the out-of-phase problem (for example, between HF and LF drivers of a 2-way speaker system).

Figure 4 shows the phase response of a 2-way speaker system. The cutoff frequency is 1.5 kHz for both the HPF (18 dB/oct, BW) and LPF (18 dB/oct, BW).

Let's focus on 1.5 kHz frequency now.

From the graph of the amplitude response, you can see that 1.5 kHz frequency sound is reproduced both by the HF and LF drivers. From the graph of the phase response, you can see that the phase difference between HF and LF is 180 degrees.

Both signal levels are equal so both cancel each other and in result, the dip is created in the amplitude characteristics. Also in the overall phase response graph, you can see that the phase suddenly changes between 1 kHz and 2 kHz. In result, the speaker system has a bad phase characteristics around the crossover point.

Figure 5 shows the phase response of the same 2-way speaker system as Figure 4, however, the speaker system is adjusted for reducing the phase difference in the range between 1 kHz and 2 kHz within 90 degrees. The slope of the phase characteristics is constant over the whole range, so the bad influence to the amplitude characteristics is minimized.

The "installation" series has smooth phase response that has the constant slope over the whole range.

<Figure 4: Influence of the phase difference to the amplitude response>

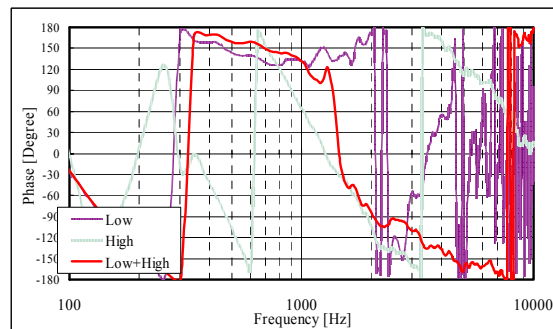
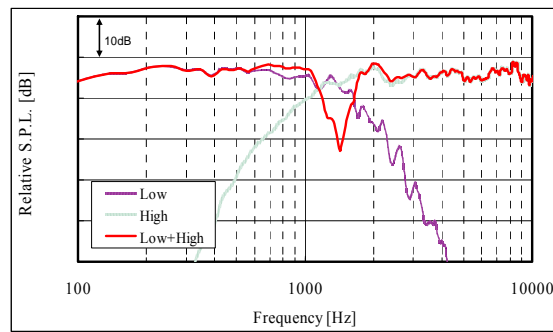

<Figure 5: Response of a speaker system that has in-phase units>

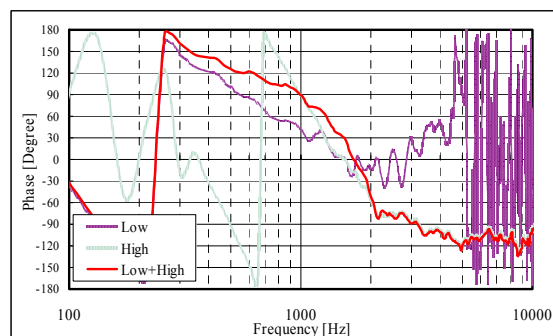
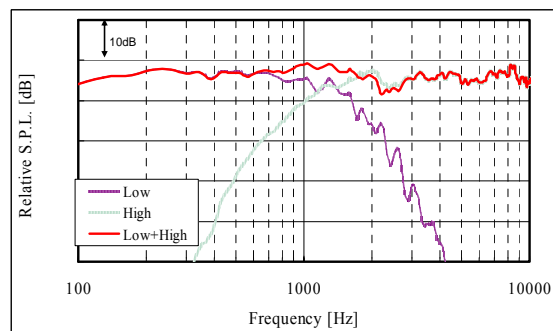

2) Discussion on phase response when multiple speaker systems are used

For installation to a hall, theater, church, etc., multiple speakers may be stacked in arrays. In such conditions, there may be a problem in the overlapped area where more than one speaker covers. That is, as described in 2-1) above, there may be a dip in the amplitude response.

This is because of the phase difference that is caused by the distance difference between the speaker position and the listening position.

Therefore, from the view point of the system design, it is very important to reduce the overlapped area but actually it is very difficult to perfectly eliminate it. Under the condition where two speakers are used as shown in Figure 6, Table 1 shows the relation between the "distance difference" and "out-of-phase frequency". The distance difference shows the difference between the distances from these speakers to the testing point. The frequency shows the point where the phase difference caused by the distance difference is 90 degrees. The parameter θ is the angle with the center axis.

Table 1 indicates the following.

When the overlapped area is within 10 degrees, the phase difference caused by the distance difference in the overlapped area is within 90 degrees at 1 kHz or less frequency, regardless of the distance from the sound source.

When the overlapped area is within 20 degrees,

the phase difference is within 120 degrees at 1 kHz or less frequency. It is thought that, under this amount of phase difference, interference can be ignored. Therefore, in this condition, it is very important to match the phase characteristics of two speakers in order to get the amplitude characteristics with no dip (as with the discussion of phase characteristics between drivers described earlier).

(Note that, practically, because the directivity of a speaker changes depending on frequency, you have to consider frequency, directivity and distance.)

<Figure 6: Considering the characteristics in the overlapped area>

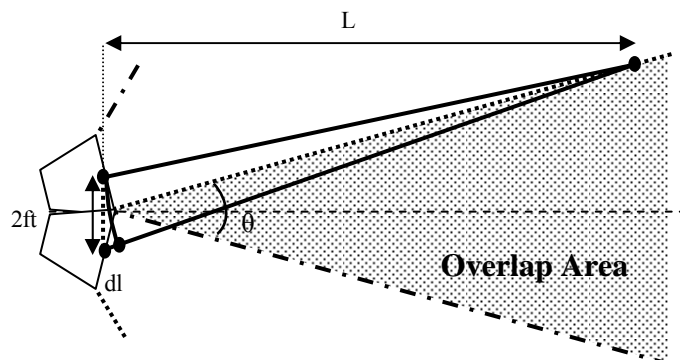

<Table 1: The relation between the distance difference and out-of-phase frequency in the overlapped area>

θ	L=6 m	L=12 m	L=24 m
5	0,174 / 3 3252 Hz	0,174 / 3.249 Hz	0,174 / 3.248 Hz
10	0,347 / 1.627 Hz	0,347 / 1.626 Hz	0,347 / 1.626 Hz
15	0,517 / 1.087 Hz	0,517 / 1.086 Hz	0,518 / 1.085 Hz
20	0,683 / 817 Hz	0,684 / 816 Hz	0,684 / 816 Hz

Phase difference = 90 degrees

θ	L=6 m	L=12 m	L=24 m
5	0,087 / 4.336 Hz	0,087 / 4.332 Hz	0,087 / 4.331 Hz
10	0,174 / 2.170 Hz	0,174 / 2.168 Hz	0,174 / 2.167 Hz
15	0,261 / 1.449 Hz	0,261 / 1.448 Hz	0,261 / 1.447 Hz
20	0,347 / 1.089 Hz	0,347 / 1.088 Hz	0,347 / 1.088 Hz

Phase difference = 120 degrees

To confirm the validity of our consideration, we made the following test.

Using the Yamaha SREV1, we created the phase differences of 90, 120 and 150 degrees at 2 kHz by simulating the impulse response that has a different inclination of phase characteristics in the frequency range.

Then we compared the frequency response at the testing point.

Figure 7 shows the test condition while Figure 8 shows the result.

The testing point is fully apart from the wall. We use a boundary microphone in order to avoid the effect of the reflected sound from the wall and floor.

All the results are standardized by the result under the condition where $\theta=0$ and no phase difference.

Both speakers have a 60x40 directivity and the degree of their side taper is 15 degree.

When there is no phase difference, if θ is 15 degrees or less, the level difference at 2 kHz or below is within 3 dB. If θ is 25 degrees or less, the level difference at 1 kHz or below is within 3 dB.

As the phase difference increases, the area

affected by the dip caused by the interference expands, as well as the dip frequency lowers. When the phase difference is 90 degrees, if θ is 15 degrees or less, the level difference at 1kHz or below is within 3 dB.

When the phase difference is 150 degrees, even if θ is 0 degrees or less, the level difference at 1kHz or below is more than 6 dB. These results show that, when using more than one speaker, it is very important to match the phase characteristics of the speakers in order to get the same response at any position in the room.

<Figure 7: Test condition>

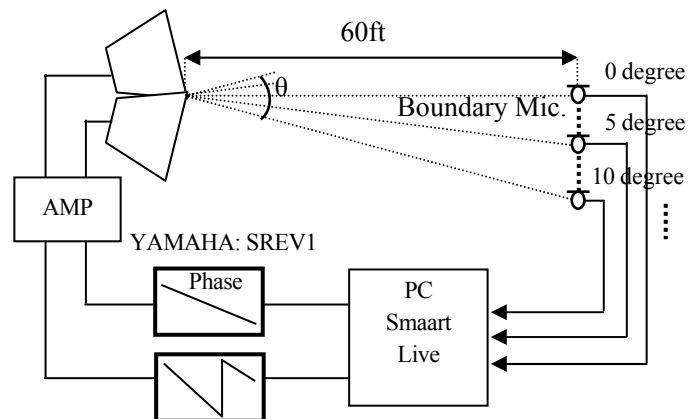

<Figure 8: Characteristics in the overlapped area>

Phase 0 degree

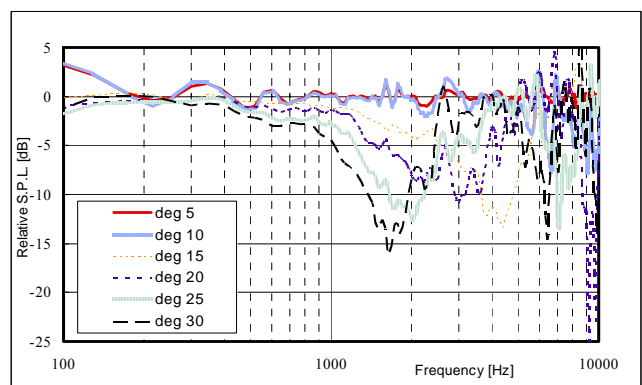

Phase 90 degrees

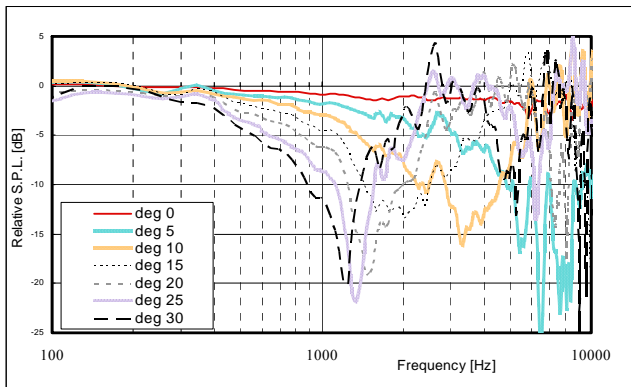

For designing the "Installation" series speakers, Yamaha focused on this point and considered it very important to match the phase characteristics not only between the same speaker models but also between different models.

<Figure 9: Variations of speaker combinations>

Phase 120 degrees

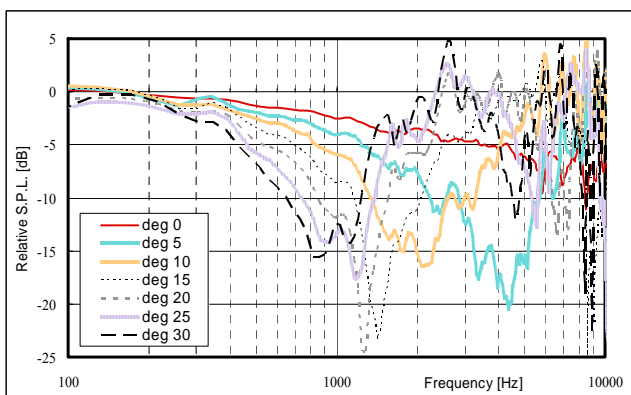

<Same enclosures, different directivities>

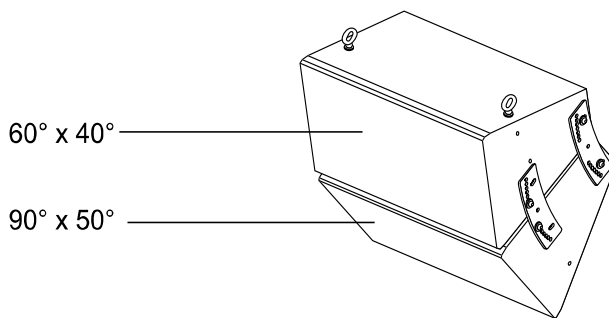

Phase 150 degrees

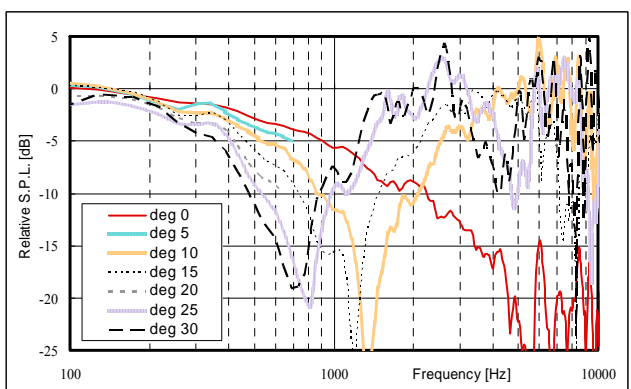

<Same enclosures, different drive modes>

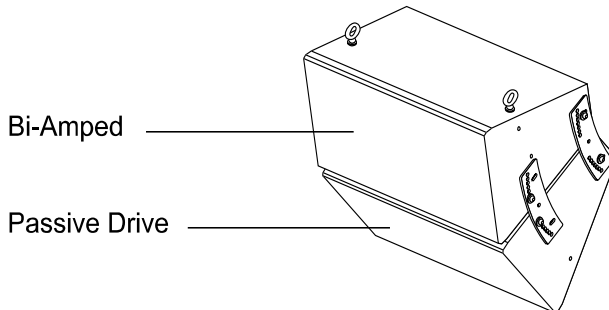

<Same enclosures, different power models>

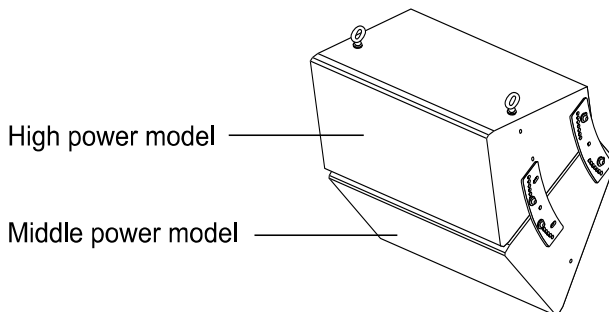

In actual speaker installation to a theater, etc., it is common to use several speaker models with different directivity according to the necessary cover range. Also, there may be several speaker handling power combinations (see Figure 9).

<Combination of different enclosure-size models>

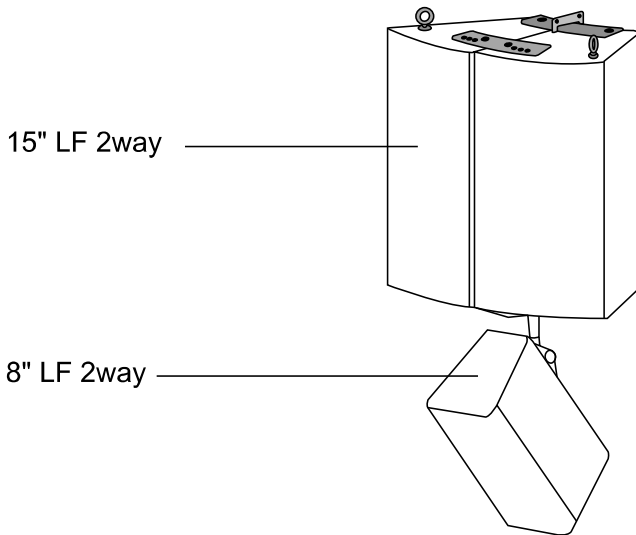

- Same phase characteristics between passive and bi-amp models with the same enclosure.
- Same phase characteristics between high-power and middle-power (will be available in the autumn of 2005) models with the same enclosure.
- Same phase characteristics between different enclosure models.
- The phase difference between speakers at 2 kHz must be within 90 degrees.

3. Design concept

According to the experiment mentioned above, we recognized a phase control as the one of the most important factor. Then, we especially focused on the balance of a phase and tone control, and aimed to realize both the "In Phase Concept" and "family sound concept". The followings are details of each concept.

1) Phase control

(1) In Phase concept

From the result described above, the phase characteristics of all speakers in this series must be the same.

- Same phase characteristics between the same enclosure models that have different directivities

(2) Using the minimum phase change type

There are two methods of controlling the phase characteristics of multi-way speaker systems.

A. Minimum phase change type

This method aims for minimizing the phase change between 20 Hz and 20 kHz. It realizes the smoothly changed phase characteristics within one lap (180 degrees to -180 degrees). It is likely to have the level-down problem of the amplitude characteristics in the frequency range where low-frequency and high-frequency drivers are crossed over.

B. Same phase slope type

This method aims for the smooth phase change over the whole frequency range. It does not aim for minimizing the phase change.

By adding a delay to the low-frequency driver to match the phase slope of the low-frequency driver to the slope of the high-frequency driver, the phase characteristics of two drivers are smoothly joined.

With this method, at the boundary of the phase

characteristics of the two drivers, the phase difference is 360 degrees. However, from the view point of boost/cut of the amplitude characteristics, it can be regarded as the same phase, which can avoid the level-down problem in the crossover range. This method is simpler and easier than the "minimum phase change type", though the phase significantly changes over the whole range.

<Figure 10: "Minimum phase change type" and "same phase slope type"

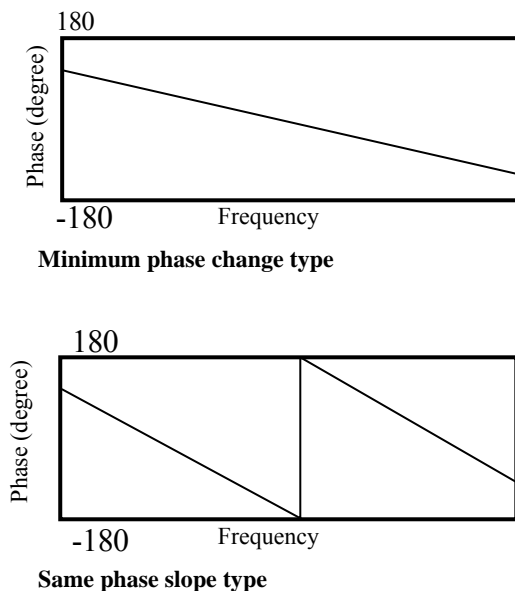

Before starting designing the "Installation" series, we made prototypes of both "minimum phase change" and "same phase slope" types, and gave a listening/comparison test. The following shows the result. When testing with a bi-amp speaker using the DSP, though there was a different nuance in the crossover range, it was hard to say which one was better. When testing with a passive speaker, the minimum phase change type with a simple

network circuit sounded better. Also, there was a fear that each model may have the different delay time of the low-frequency driver if all the "Installation" series speakers were adjusted by applying the "same phase slope" method. This might cause the problem when using more than one speaker together.

By these reasons above, we decided to use "minimum phase change type".

2) Tone quality control

(1) Target sound

We set the main targets of the "installation" series to halls, theaters and churches. Such facilities might have conferences, music concerts, musicals, lectures, etc. Therefore, for the SR system, offering clear and good sound was the minimum requirement, as well as providing enough audible level at any position in the area. Furthermore, it was also required to offer high-fidelity sound for vocal and music instruments, as well as for playback of music or ambient sound.

Therefore, for tone quality of the "Installation" series products, we aimed for realizing the following, in addition to the flat amplitude characteristics.

Speech intelligibility

- Well-balanced and well-separated tone for music

- Non coloration sound regardless of the total level
- Same timbre at any position within the directivity range
- Adequate audio image size of each source

(2) Family Sound Concept

For a facility in a hall, theater or church, auxiliary speakers such as under-balcony speaker and frontfill speaker may be used for audience, in addition to the main speakers.

The sounds generated by these speakers are mixed in the room/hall space. However, it was very difficult to get the same timbre at any position in the room/hall because the timbre of each speaker is different if the size or model is different (even though the manufacturer is the same).

Now, Yamaha introduces "Family Sound Concept". According to this concept, all speaker models in the same series has the same tone color.

- Unification of the tone color between the different directivity models using the same enclosure
- Unification of the tone color between the passive and bi-amp modes of the same model
- Unification of the tone color between the high-power and middle-power models using the same enclosure
- Unification of the tone color between the different enclosure models

(3) Minimizing the electronic compensation

The equalizing operation compensates the amplitude response; on the other hand it causes deterioration of the phase characteristics. The more you compensate the amplitude response, the more the phase changes.

So we aimed for minimizing the electronic compensation using the equalizer.

Especially for the crossover range, we aimed not to use the equalizer at all.

(4) Cooperation with an outside speaker designer

We decided to design the speakers in cooperation with an outside speaker designer. The leader of the Yamaha speaker developing team was Akira Nakamura. He was the developer of the "NS1000M" long-seller hi-fi speaker, the "NS10M" de facto standard speaker in the studio and the "MSP series" powered monitor speakers.

We appointed Mr. Michael Adams as the outside speaker designer. He is not only a veteran speaker designer but also has a long experience as an SR engineer and currently he is the chief designer of "Audio Composite Engineering", a speaker designing company in U.S.A.

He understood and Yamaha's concept that seemed to be very difficult to make it realize. He is one and only speaker designer who has golden ears of an SR engineer.

4. Designing and developing style

Designing, as well as developing a prototype, was made in three separate stages.

In the first stage, Proto 1 for the first sound evaluation was developed. In the second stage, Proto 2 was developed, reflecting the result of the Proto1 evaluation. The basic designing of the enclosure and horn, as well as driver selection, was done by "Audio Composite Engineering".

Yamaha made the detailed data measurement and listening test not only in the anechoic room but also in the practical environment. Then the analyzed results, as well as summaries of issues and resolutions, were reported to "Audio Composite Engineering" for feedback.

In the third stage, based on Proto 2, the preproduction was made in the factory where the final products were produced, using the parts and materials for mass production. This was the trial production stage for checking the quality of the final mass production products. Various enclosures using different materials or paints were made. Various components were mounted to these enclosures and tested.

The following reports the current situation for each component.

- Horn

We evaluated horns by measuring data such as the phase response and amplitude response, as

well as giving listening tests to check clearness, resolution, audio image size, etc.

The horn with 1.4-inch throat used for 15-inch and 12-inch models improved sound penetration and resolution. This is the maximum size horn that can be fitted in the enclosure. The material is FRP that is enhanced using glassfiber, and deadened by adding the anti-vibration material.

All horns are rotatable within the 90 degree range.

- Compression driver for high-frequency range

After repeated listening tests for pursuing the family sound, we selected drivers. In result, all selected drivers are made by the same manufacturer.

The driver used for the 15-inch or 12-inch model features the 3-inch voice coil and titanium diaphragm. The edge and diaphragm are integrated. The edge is tangential type for higher durability and better tone quality.

- Woofer for low-frequency range

To prevent collapsing the sound image at high power, the 15-inch and 12-inch woofers use 4-inch voice coils.

The woofer has been carefully selected by considering the following.

- Offering both the high damping factor and smooth low-frequency response
- Sonic matching with the enclosure
- Smooth crossover to high-frequency

The magnetic circuit uses a large ferrite magnet for enhancing the magnetic density, resulting clear and crisp sound.

- Enclosure

After the listening tests, we decided to use 11-ply Finnish Birch for the enclosure material.

The tuning frequency is set to the point where the sound pressure from the port affects the low-frequency response most effectively.

We made prototype in which the tuning frequency point was calculated by computer simulation and gave the listening tests repeatedly for checking the matching between the enclosure and woofer, then made change for improvement.

As for the enclosure shape, to keep the clear sound, we set the side panel and baffle to the same height. This eliminates sound reflection by the side panel, which may make the sound unclear.

We reinforce the inside by bracing, considering the strength and resonance. In result, we ensure the clear tone quality with no speaker box noise. 25-mm glass wool is used inside the enclosure as the sound-absorption material, resulting the well-balanced low-frequency sound that is tight but sustained.

To get the higher sound penetration, 63 % of the metal grille is open.

- Network

To prevent the sound deterioration by inserting the network, the network is very simple.

For the low-frequency network of the 15- and 12-inch models, a coil binding 15-gauge copper wire to the large silicon steel plate core and a large film capacitor with small $\tan \theta$, ensuring the high resolution sound even at high power input.

To get the same phase response and amplitude response as those at the bi-amp operation, we made computer simulation and actual measurement repeatedly until we completed the network design.

As a whole, we could accomplish both "In Phase Concept" and "Family Sound Concept". We could minimize the phase change over the whole range and obtain the gentle descending phase characteristics with no sudden phase change, as well as obtain the smooth amplitude characteristics.

5. Phase characteristics of the "Installation" series

The following graphs show the phase characteristics of the "Installation" series and the competition model.

From these graphs, you can see that the phase characteristics of the "Installation" series are almost the same, regardless of directivity, drive mode and model.

<Figure 11: Phase characteristics comparison>

YAMAHA INSTALLATION SERIES

Comparison between different directivity patterns

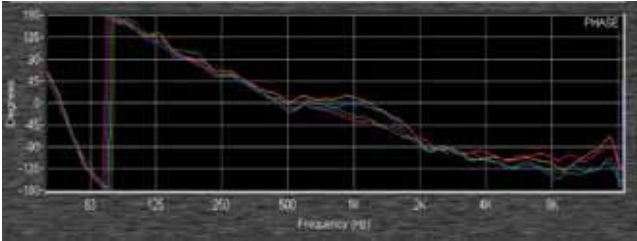

Orange: IF2115/64/bi-amp Blue: IF2115/95/bi-amp
 Red: IF2115/99/bi-amp Green: IF2115/AS/bi-amp

Competition model

Comparison between different directivity patterns

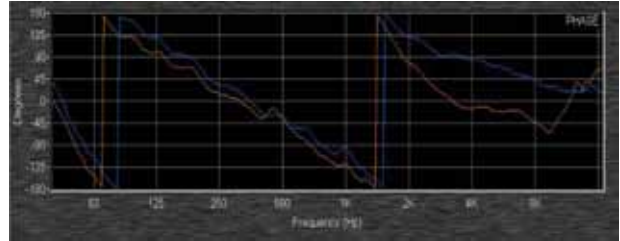

Orange: Competitor's 15" LF 2way 60x40 bi-amp
 Blue: Competitor's 15" LF 2way 90x50 bi-amp

Comparison between different drive modes

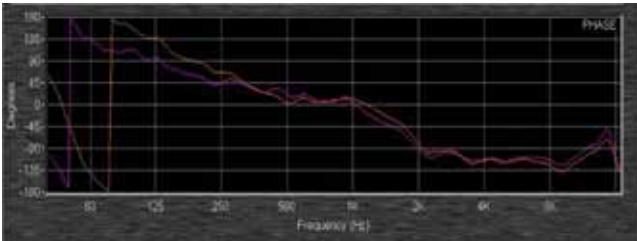

Orange: IF2115/64/bi-amp
 Purple: IF2115/64/passive

Comparison between different drive modes

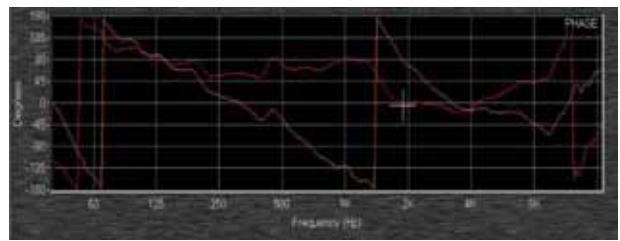

Orange: Competitor's 15" LF 2way 60x40 bi-amp
 Red: Competitor's 15" LF 2way 60x40 passive

Comparison between models

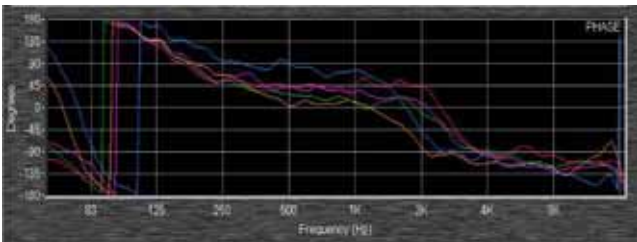

Orange: IF2115/95 bi-amp Blue: IF2112/95 bi-amp
 Green: IF2208 Purple: IF2108
 Red: IF2205

Comparison between models

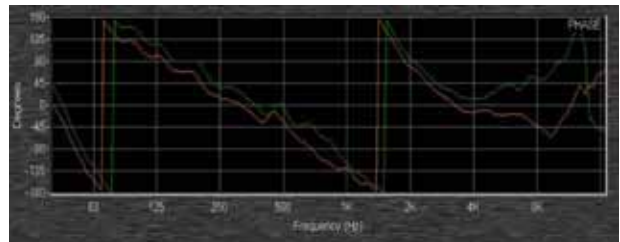

Orange: Competitor's 15" LF 2way 60x40 bi-amp
 Green: Competitor's 12" LF 2way 60x40 bi-amp

6. Summary

In the autumn of 2004, we invited the estimators and had the meeting at "Audio Composite Engineering" for evaluating the tone quality of the final prototype.

Using CDs and microphones that were brought by estimators, evaluation was carefully made.

The meeting finished amid a storm of applause.

In Japan, we also had the similar meeting for evaluating the tone quality.

Both meeting ensured us that the "Installation" series realized our design concept and offered top-quality sound. Especially, realizing the family sound concept was well received. Through the speech test in English and Japanese using a microphone, it was proven that the series could amplify voices in both languages very clearly.

Yamaha "Installation" series speakers for facilities solve the problems caused by using multiple speakers together. We really hope you confirm its tone quality, tone color matching when using more than one speaker together, linear reaction of EQ, etc.

Yamaha is planning to add the 3-way model and 2-way middle-power model to the series in the future. Yamaha is also planning to introduce the digital speaker processor at the end of 2005.

Regarding DSP processing for driving the "Installation" series, you can use general speaker processors because no special crossover filter and

EQ are used. However, we believe that the Yamaha "DME24N/64N" are the best combination in terms of tone quality. We are planning to show you the DSP setting data and EASE data at the Yamaha web site in the near future. Note that we used the Yamaha PC-01N series power amplifier in the final process of tone adjustment.

Currently, in parallel with hardware developing for these items, we are developing a simulation software application that can be used easily in the designing stage of the sound system. All you have to do is to enter data of the room shape, room size, sound pressure level at the listening position.

Based on the data, this application will recommend you the best array configuration. It also allows you to simulate equalization for compensation of the array characteristics. The result of equalizing simulation can be stored to the Yamaha DME24N/64N as a library file.

By using this simulation software application with the Yamaha "Installation" series, you can dramatically save time for setting adjustment.

Finally, we would like to extend our heartfelt thanks to Audio Composite Engineering and Mr. Michael Adams.

Reference:

- [1] G. Davis and R. Jones, "Sound Reinforcement Handbook, Second Edition," Yamaha, 1989
- [2] D. Davis and C. Davis, "Sound System Engineering, Second Edition," Focal Press, 1997