



SOUND REINFORCEMENT APPLICATION GUIDE

2010

A TRADITION OF
INNOVATIVE SOLUTIONS



www.yamahaproaudio.com
www.yamaha.com/proaudio

Innovative Solutions for Live Sound

The term “live sound” covers a lot of ground, and no two applications are exactly alike. You might only need to amplify a single microphone for a business meeting, or mix many sources and deliver several kilowatts of power at an outdoor concert. For both these scenarios, and everything in between, Yamaha has the gear you need to get the job done with maximum quality, efficiency and ease.

When choosing equipment for your application, you’ll need to consider the following points:

1. Scale

How big is your audience? How big is the venue or area you need to cover? For larger setups, you will need to have enough speakers and power to cover the area, smaller venues with space limitations require equipment that can provide the required functionality and performance without getting in the way.

2. Sources

Do you only need one or two microphones for speech or vocals? Will you be supporting live music using numerous microphones and line-level inputs? Do you need to handle recorded sound effects or background music? All these factors will determine the size and type of mixer you’ll need, as well as monitoring and output equipment (equalizers, power amplifiers, and speakers).

3. Indoors or Outdoors

The requirements for indoor and outdoor sound can be quite different. While power, coverage and sound quality are relatively easy to handle indoors, these factors often require extra care outdoors where there are no room reflections to reinforce the sound and your audience may be spread out over a large area. You also have nature to deal with when working outdoors, so you need a setup that can withstand less-than-favorable weather conditions.



Explanation of icons

96kHz compatible	One-switch Compressor equipped	Cubase AI4 bundled
MIDI format compatible	One-knob Compressor equipped	YAMAHA Speaker Processing equipped
VCM Effects pre-installed	Frequency Response Correction System equipped	YAMAHA EEEngine equipped
REV-X Reverb pre-installed	Feedback Channel Locating System equipped	model Class-D Amp equipped
MY16 series compatible	Multi-band MAXIMIZER equipped	Max non-clip level of analog output +24dB
SPX EFFECT equipped	Automatic Feedback Suppressor equipped	Max non-clip level of analog output +18dB

Table of Contents

Band and Entertainment	4
Band Rehearsal 1	4
Band Rehearsal 2	4
Piano Bar	5
Sports Bar	5
Small Stage	6
Large Outdoor Stage	7
Compact Digital Solution for 2-Band Events	8
Full-Fledged Live SR and Recording	9
Festival	10
Country Fair	11
Church	12
Small Church	12
Mid-sized Church	12
House of Worship Installation	13
Party and DJ	15
Live Music at Home	15
Wedding Ceremony	15
Dinner Presentation	17
Outdoor Dance Event	18
School and Business	19
Acoustic Music	19
Conference Room	19
Lecture Hall	20
Gymnasium	20
Point of Sale	21
Portable Solution	22
Product Lineup	24
Mixers	26
IM8 Series	26
MG Series	27
MG32/14FX, MG24/14FX	28
EMX512SC, EMX312SC, EMX212S	28
EMX5016CF, EMX5014C	29
01V96VCM	29
Signal Processors	31
SPX2000	31
Q2031B	31
Power Amplifiers	31
P-Series	31
SR Speakers	32
Club V Loudspeakers S-Series	32
Club V Loudspeakers C-Series	32
BR-Series Speakers	33
MSR Series Speakers	34
MS101III	35
Pocket Recorders	35
POCKETRAK C24 / W24	35
Portable PA System	36
STAGEPAS Series	36
Powered Monitor Speakers	38
MSP STUDIO Series Speakers	38
HS Series Speakers	38
Peripherals	39
Tips 1 – PA Basics, Mixer Essentials	14
Tips 2 – 1.Cable Types, 2.Connector Types	16
Tips 3 – Selecting PA Equipment	25
Simple Steps To Better Sound ① Gain is the key to level control	17
Simple Steps To Better Sound ② Connection and power switching order	21
Simple Steps To Better Sound ③ Feedback control	21
Simple Steps To Better Sound ④ Why use monitor speakers?	33
Simple Steps To Better Sound ⑤ Boosting system power	34
Topic – An Interview with the EMX/MG Design Team	30

• Specifications and appearance are subject to change without notice.
• All trademarks and registered trademarks are property of their respective owners.

Band Rehearsal 1

If you rehearse with real drums and other instruments at realistic levels, you'll need some vocal amplification for well-balanced, productive rehearsals. Even if the band is relatively quiet, vocalists need to practice with microphones and amplified sound if amplification will be used on stage. Compression can also help to make the vocal sound stand out. This simple system featuring the EMX312SC powered mixer, a pair of BR12 speakers, an SM10V (CM10V) for monitoring, and a couple of good microphones is ideal.

System Chart

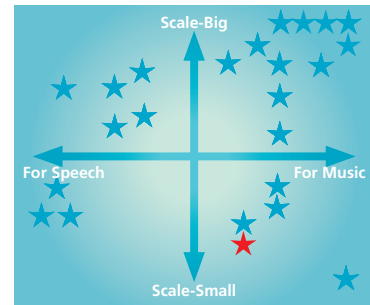

Mic:
1 ~ 8 channels
Line:
Four stereo
Scale:
Rehearsal studio, approx. 30 square meters
Audience:
5 ~ 8 people

Sample Application

A small-scale setup that excels in compactness and portability



Good Reasons For Choosing Yamaha

- EMX312SC**
- All-in-one model with superior portability.
 - Eight microphone inputs.
 - Built-in power amplifier for easy setup.
 - One-knob compression for smooth, up-front vocal sound.
 - Built-in effects add polish to the mix.
 - Separate equalization for main and monitor speakers

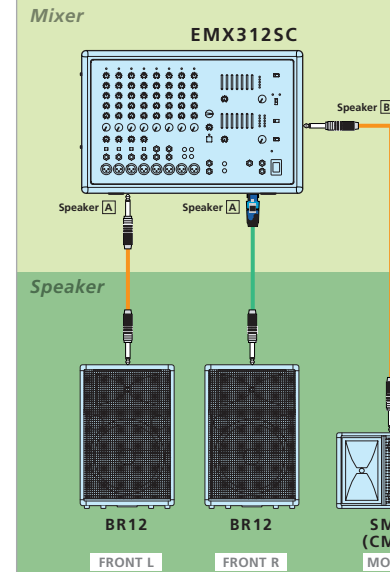

- BR12**
- Compact and lightweight with high-power output.
- SM10V (CM10V)**
- Small 10-inch monitors chosen to ensure coverage, and supply clear monitor sound to performers.

Equipment List

Powered Mixer	EMX312SC	1
Main Speaker	BR12	2
Monitor Speaker	SM10V (CM10V)	1

Piano Bar

Here's a system that's ideal for small venues hosting musical entertainment ranging from solo pianists to jazz trios with a vocalist. The volume may be low, but vocalists need solid monitor sound to deliver their best performance. Compression can be a real advantage, too. In this example, an EMX512SC powered mixer delivers the house sound via a pair of S112V (C112V) speakers, while a single SM12V (CM12V) provides quality monitor sound.

System Chart

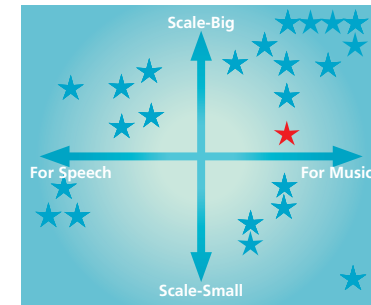

Mic:
1 ~ 8 channels
Line:
Four stereo
Scale:
Jazz club with small stage
Audience:
30 ~ 50 people

Sample Application

A small, easy-to-handle system delivering high sound quality

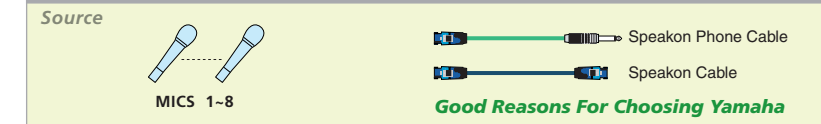

Good Reasons For Choosing Yamaha

- EMX512SC**
- Built-in digital SPX signal processing makes it easy to achieve a full, rich vocal sound even in small piano-plus-vocal settings. Stereo graphic EQ provides precise tonal shaping capability.
 - Up to eight microphone inputs. A benefit in jazz clubs with limited stage space.
 - A rack-mount kit is available for even further space savings. Minimum space requirements, but serious 500 + 500 watt output (into 4Ω).
 - Compression helps maintain ideal vocal balance with the band.
 - FCL helps to keep feedback in check even when the vocalist moves around.
 - Up to 8 microphone inputs can handle multiple acoustic instruments.

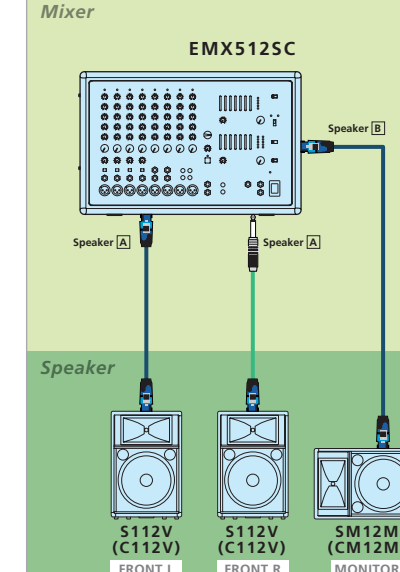

- S112V (C112V)**
- Durable carpet finish takes rough handling in stride.
 - Compact and lightweight with high power output.
 - An ideal match for mixers that feature YS Processing.
- SM12M (CM12M)**
- Small vocal monitor takes up minimum stage space.

Equipment List

Powered Mixer	EMX512SC	1
Main Speaker	S112V (C112V)	2
Monitor Speaker	SM12M (CM12M)	1

Band Rehearsal 2

Rehearsals in larger rooms with many musicians require substantial sound support. Here's a system that will comfortably handle multiple sources—full drum-set mic setups, brass sections, and more—while powering four main speakers and two monitors. The EMX5016CF features 16 input channels and delivers a healthy 500 watts per stereo channel to four S112V (C112V) speakers. In this system a pair of powered MSR400 speakers are used for monitoring.

System Chart

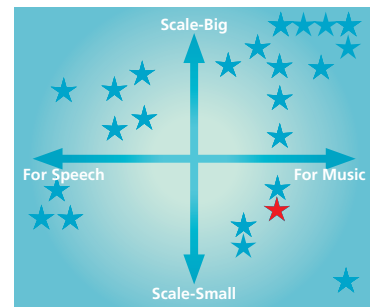

Mic:
1 ~ 12 channels
Line:
Four stereo
Scale:
Four-car garage
Audience:
10 ~ 15 people

Sample Application

A compact setup with serious microphone mixing and one-take recording capability



Good Reasons For Choosing Yamaha

- EMX5016CF**
- Solid 500 watts + 500 watts power output with pro-class mixing capability.
 - Advanced one-knob compression for refined mixes.
 - FRC (Frequency Response Correction) system automates room equalization.
 - Digital stereo graphic equalizer with presets and memory.
 - Multi-band Maximizer enhances musical impact.
 - Automatic feedback suppression.

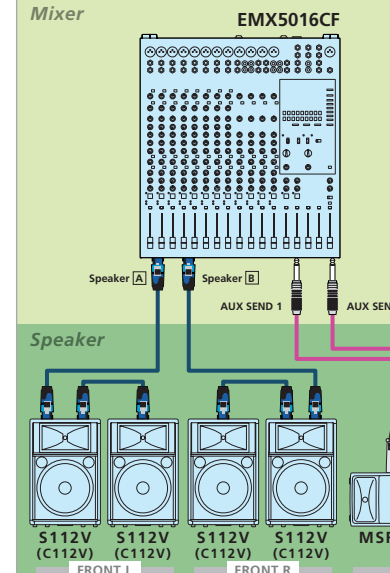

- S112V (C112V)**
- Compact and lightweight with high power output.
 - An ideal match for mixers featuring YS Processing.
- MSR400**
- Cabinet design allows multiple placement options.
 - Powered speaker with direct volume control for monitor applications.

Equipment List

Powered Mixer	EMX5016CF	1
Main Speaker	S112V (C112V)	4
Monitor Speaker	MSR400 (Powered)	2

Sports Bar

There's no denying that while much of the impact of a sports event is visual, sound plays a huge role as well. Sports bars that show live or recorded sports on 50" or larger screens have the visual aspect pretty much covered, now here's a sound system that can really bring the action to life. And when it's not sports time, it serves as an outstanding BGM system as well. An MG82CX handles the required inputs with room to spare, and a pair of MSR250 powered speakers deliver big, dynamic sound.

System Chart

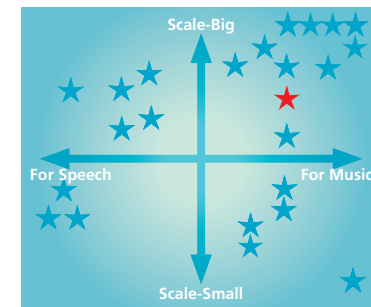

Mic:
1 ~ 4 channels
Line:
Four stereo
Scale:
Sports bar with hanging or projector TV
Audience:
30 ~ 50 people

Sample Application

A compact system with plenty of stereo inputs



Good Reasons For Choosing Yamaha

- MG82CX**
- Built-in channel compression for smooth mixes.
 - Top quality components throughout, including reliable Neutrik XLR connectors.
 - Remarkably compact and lightweight.
 - Optional BMS-10A Mic Stand Adaptor allows microphone-stand mounting for easy placement and access
 - Renowned Yamaha SPX effects built in.

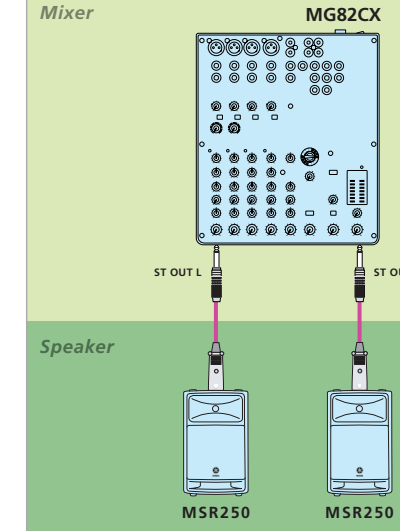

- MSR250**
- Powerful powered speaker that won't get drowned out by the cheers of the audience.
 - Max. 250W total, output power.

Equipment List

Mixer	MG82CX	1
Powered Speaker	MSR250	2

Small Stage

This small-but-serious system will cover small to medium-sized live venues with thoroughly professional quality and versatility. The MG206C mixer offers plenty of input capacity. FOH sound is delivered by P5000S and P7000S power amplifiers driving S115V (C115V) full-range speakers and SW118V (CW118V) subwoofers, respectively. For monitoring, a pair of SM15Vs (CM15Vs) is powered by a P5000S amplifier with a Q2031B equalizer for feedback control. An SPX2000 professional multi-effect processor could be added for additional vocal processing. The system also features a STAGEPAS 150M portable PA system for keyboard monitoring. With the main PA mixer's AUX SEND 3 connected to Input 5 (mono) of the STAGEPAS mixer, the STAGEPAS speaker is able to operate as a monitor. In addition, input from keyboards and synths can be mixed on the STAGEPAS mixer and then sent to the main PA.

System Chart

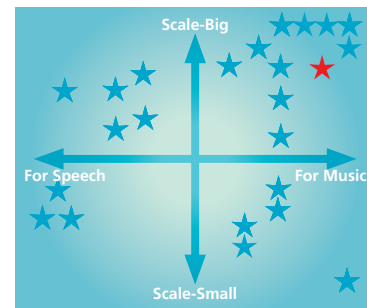

- Mic:** 1 ~ 16 channels
- Line:** 4 stereo
- Scale:** Medium-size live space with stage
- Audience:** 150 ~ 200 people

Sample Application

Medium-size system for powerful live sound

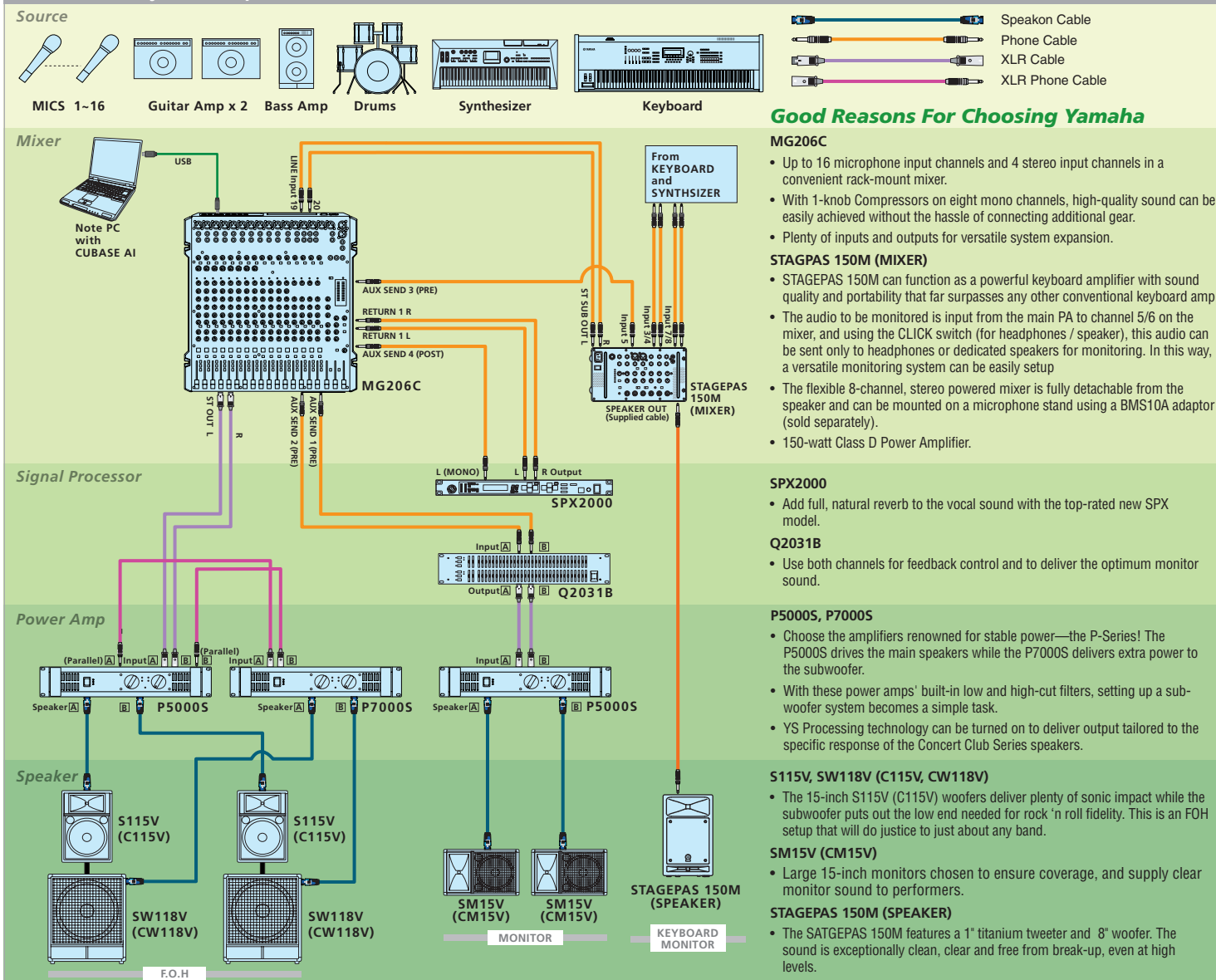

Good Reasons For Choosing Yamaha

- MG206C**
 - Up to 16 microphone input channels and 4 stereo input channels in a convenient rack-mount mixer.
 - With 1-knob Compressors on eight mono channels, high-quality sound can be easily achieved without the hassle of connecting additional gear.
 - Plenty of inputs and outputs for versatile system expansion.
- STAGEPAS 150M (MIXER)**
 - STAGEPAS 150M can function as a powerful keyboard amplifier with sound quality and portability that far surpasses any other conventional keyboard amp.
 - The audio to be monitored is input from the main PA to channel 5/6 on the mixer, and using the CLICK switch (for headphones / speaker), this audio can be sent only to headphones or dedicated speakers for monitoring. In this way, a versatile monitoring system can be easily setup
 - The flexible 8-channel, stereo powered mixer is fully detachable from the speaker and can be mounted on a microphone stand using a BMS10A adaptor (sold separately).
 - 150-watt Class D Power Amplifier.
- SPX2000**
 - Add full, natural reverb to the vocal sound with the top-rated new SPX model.
- Q2031B**
 - Use both channels for feedback control and to deliver the optimum monitor sound.
- P5000S, P7000S**
 - Choose the amplifiers renowned for stable power—the P-Series! The P5000S drives the main speakers while the P7000S delivers extra power to the subwoofer.
 - With these power amps' built-in low and high-cut filters, setting up a subwoofer system becomes a simple task.
 - YS Processing technology can be turned on to deliver output tailored to the specific response of the Concert Club Series speakers.
- S115V, SW118V (C115V, CW118V)**
 - The 15-inch S115V (C115V) woofers deliver plenty of sonic impact while the subwoofer puts out the low end needed for rock 'n roll fidelity. This is an FOH setup that will do justice to just about any band.
- SM15V (CM15V)**
 - Large 15-inch monitors chosen to ensure coverage, and supply clear monitor sound to performers.
- STAGEPAS 150M (SPEAKER)**
 - The STAGEPAS 150M features a 1" titanium tweeter and 8" woofer. The sound is exceptionally clean, clear and free from break-up, even at high levels.

Equipment List

Mixer	MG206C	1	Speaker	S115V (C115V)	2	Graphic EQ	Q2031B	1
Power Amp	P5000S	2	Woofer	SW118V (CW118V)	2	Digital Multi Effects	SPX2000	1
Power Amp	P7000S	1	Monitor Speaker	SM15V (CM15V)	2	Portable PA System	STAGEPAS 150M	1

Large Outdoor Stage

Outdoor sound poses some unique problems, and power and speaker coverage are of prime importance. The system shown here delivers three kilowatts to FOH via three P5000S power amplifiers and a combination of S215V (C215V) full-range speakers and SW218V (CW218V) subwoofers. An additional 2.8 kilowatts is allotted for monitoring via four P3500S amps and SM15V (CM15V) monitor speakers. The MG32/14FX console handles the wide range of inputs and signal processing often required at outdoor music events.

System Chart

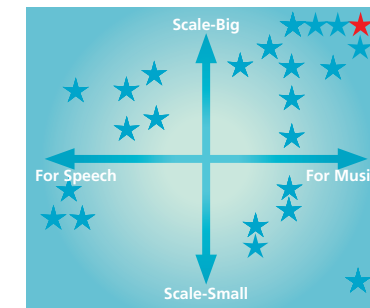

- Mic:** 1 ~ 24 channels
- Line:** Four stereo
- Scale:** Large outdoor concert stage
- Audience:** 500 ~ 1,000 people

Sample Application

Large-scale support for long-running live events

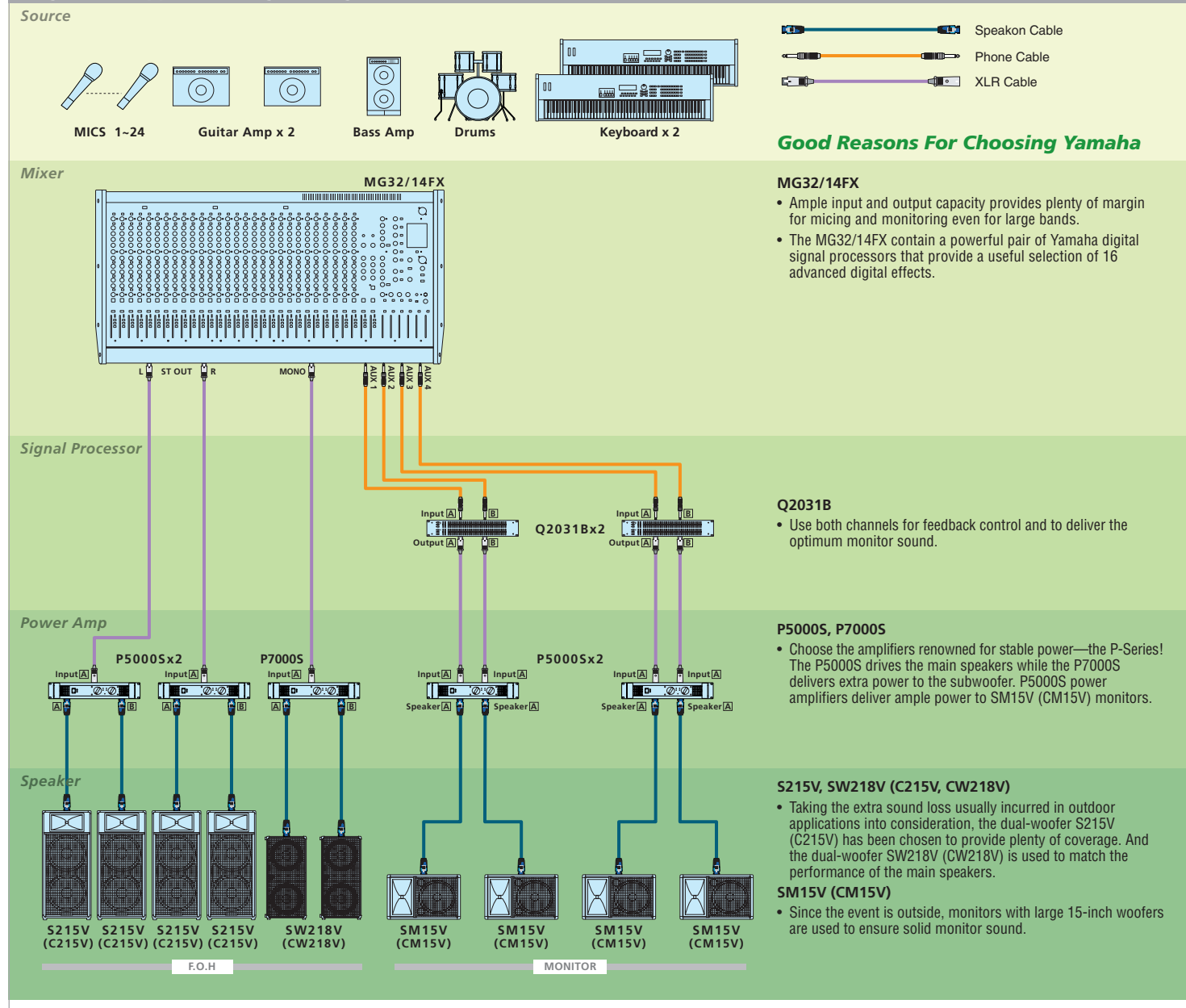

- Speakon Cable
- Phone Cable
- XLR Cable

Good Reasons For Choosing Yamaha

- MG32/14FX**
 - Ample input and output capacity provides plenty of margin for mic'ing and monitoring even for large bands.
 - The MG32/14FX contain a powerful pair of Yamaha digital signal processors that provide a useful selection of 16 advanced digital effects.
- Q2031B**
 - Use both channels for feedback control and to deliver the optimum monitor sound.
- P5000S, P7000S**
 - Choose the amplifiers renowned for stable power—the P-Series! The P5000S drives the main speakers while the P7000S delivers extra power to the subwoofer. P5000S power amplifiers deliver ample power to SM15V (CM15V) monitors.
- S215V, SW218V (C215V, CW218V)**
 - Taking the extra sound loss usually incurred in outdoor applications into consideration, the dual-woofer S215V (C215V) has been chosen to provide plenty of coverage. And the dual-woofer SW218V (CW218V) is used to match the performance of the main speakers.
- SM15V (CM15V)**
 - Since the event is outside, monitors with large 15-inch woofers are used to ensure solid monitor sound.

Equipment List

Mixer	MG32/14FX	1	Speaker	S215V (C215V)	4	Graphic EQ	Q2031B	2
Power Amp	P5000S	4	Woofer	SW218V (CW218V)	2			
Power Amp	P7000S	1	Monitor Speaker	SM15V (CM15V)	4			

Compact Digital Solution for 2-Band Events

Large music events featuring two or more bands can involve a large amount of sound reinforcement gear. Here's a compact digital system that can handle up to 80 input channels in all while allowing easy switching between completely different band setups. The pair of 01V96V2 digital consoles used provide all the effects and dynamics processing you'll need built-in, so you won't even need outboard processor racks.

System Chart

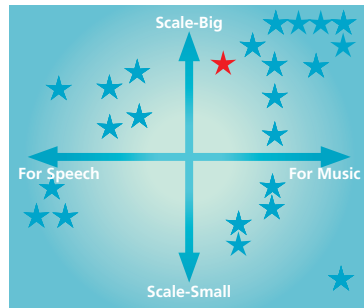

Mic and Line:
Max. 80 channels

Scale:
Large events or festivals featuring two or more bands. Plenty of capacity is also provided for announcements and commentary.

Audience:
300 ~ 500 people

Sample Application

Large Festival Featuring Two Bands

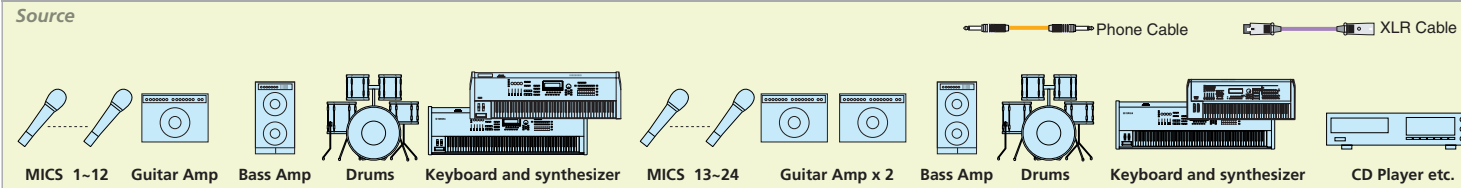

Good Reasons For Choosing Yamaha

- 01V96VCM x 2**
- With the addition of an MY16 expansion card, two 01V96VCM consoles can be cascaded to provide up to 80 simultaneous inputs.
 - Scene memory allows instant changes for different bands or even different songs.
 - Compression provided on all channels.
 - MY card slot allows flexible I/O expansion and selection.
 - Yamaha's highly regarded VCM Channel Strip processors and REV-X reverb built in.

- Q2031B**
- Feedback control and monitor EQ.

- MSR400**
- Powerful 400-watt output and outstanding sound quality from compact, lightweight powered speakers. Ideal for front-of-house sound as well as monitoring.
- MSR800W**
- A perfect sonic and visual match for the MSR400, the MSR800W subwoofer delivers up to 800 watts of power.

Equipment List

Mixer	01V96VCM	2	Monitor Speaker	MSR400	4
Graphic EQ	Q2031B	2	Subwoofer	MSR800W	1
Speaker	MSR400	2			

Full-Fledged Live SR and Recording

This powerful sound reinforcement (SR) solution for the live performance environment uses a single IM8-24 mixing console to handle both FOH and monitor functions. Offering 24 mono and 4 stereo inputs, extensive output connectivity, best-in-class sound quality, and a highly-functional, ergonomic panel layout, the IM8-24 can easily satisfy even the most demanding of professionals. And using Steinberg's Cubase AI, which is bundled with the mixer, you can easily record live performances on a PC. Despite its compact design, the IM8-24 is ideal for a wide range of professional applications, and when combined with a full set of powered speakers, for example, provides a highly-portable solution for the live-performance environment. In houses of worship and other small venues, this type of setup is ideal when equipment needs to be moved around.

System Chart

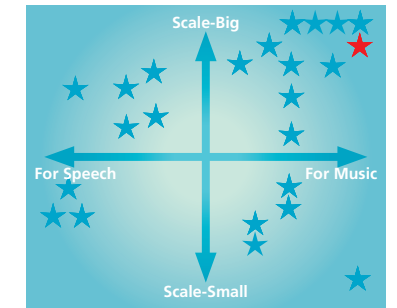

Mic:
1 ~ 24 channels

Line:
4 stereo

Scale:
Central outdoor stage

Audience:
100 ~ 500 people

Sample Application

Digital Recording and Remixing of Live Sound

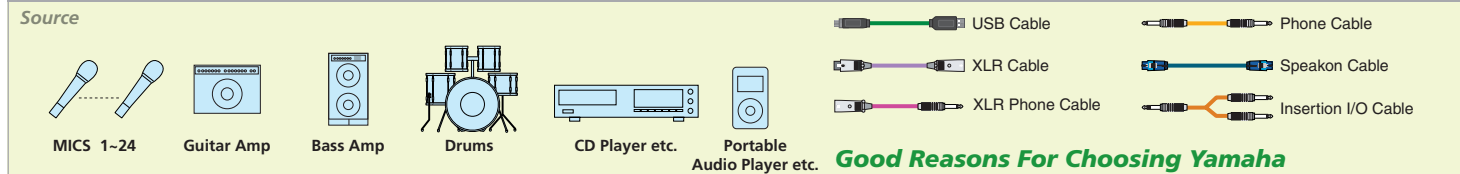

Good Reasons For Choosing Yamaha

- IM8-24**
- To ensure faultless quality control, the IM8 series is produced and assembled at the same domestic plant as the PM series, mainstay of Yamaha's lineup of professional mixing consoles.
 - Meticulously-refined sound quality easily satisfies the exacting requirements of the professional environment.
 - Newly-developed faders with 100-mm stroke length deliver the precision and accuracy required for specialized applications.
 - With 1-knob compressors integrated into all mono channels, a high-quality sound can be achieved easily and without the need for complicated settings or connections.
 - Portable audio players and the like can be conveniently connected via the front panel's 2TR IN jack.
 - With all input channels capable of receiving microphone input and with 4 stereo input channels, 8 GROUP OUT channels, 8 AUX busses, and 4 MATRIX OUT channels, the IM8-24 offers extensive I/O connectivity.
 - External power supply maximizes console performance - dual power supplies can be used for redundant failsafe operation.

- SPX2000**
- Add full, natural reverb to the vocal sound with the top-rated new SPX model.

- Q2031B**
- Use both channels for feedback control and to deliver the optimum monitor sound.

- P5000S, P3500S**
- The P5000S and P3500S are used to power the main speakers.
 - With these power amps' built-in low and high-cut filters, setting up a subwoofer system becomes a simple task.
 - YS Processing technology can be turned on to deliver output tailored to the specific response of the Concert Club Series speakers.

- S115V (C115V)**
- These speakers cover the entire service area from four points on the temporary stage. 15-inch woofers are chosen to ensure solid coverage.
- SW218V (CW218W)**
- the dual-woofer SW218V (CW218V) is used to match the performance of the main speakers.
- SM12V (CM12V)**
- Compact 12-inch monitors put out focused stage monitor sound.

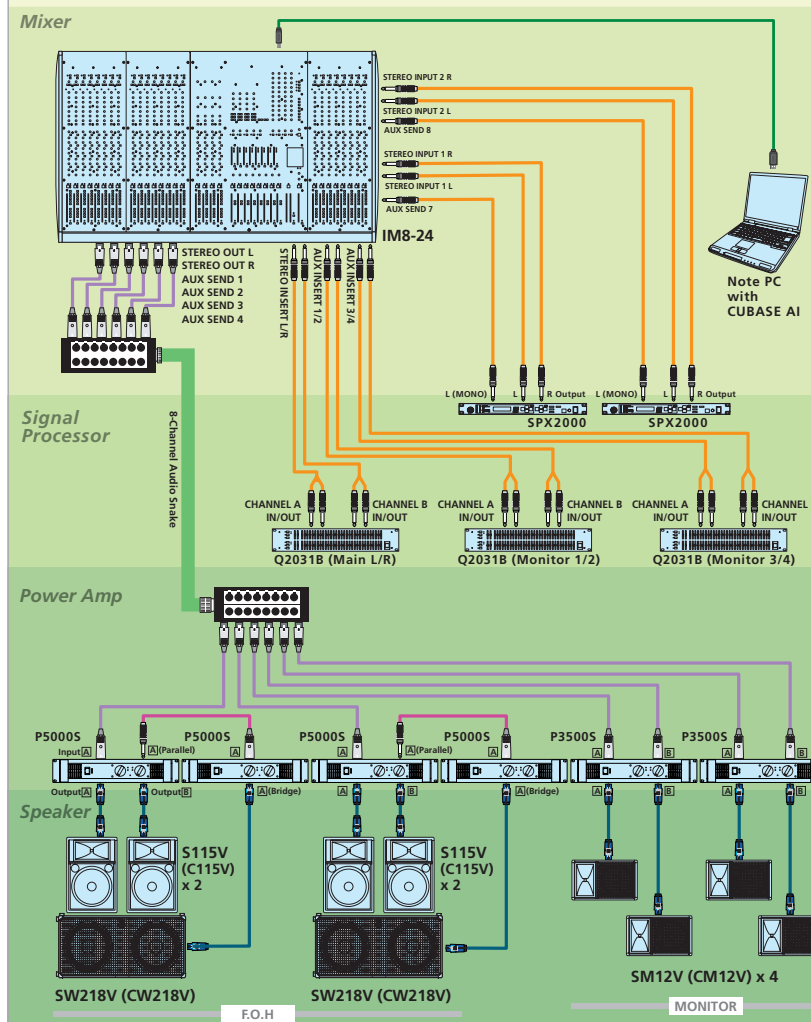

Equipment List

Mixer	IM8-24	1	Speaker	S115V (C115V)	4	Digital Multi Effects	SPX2000	2
Power Amp	P5000S	4	Subwoofer	SW218V (CW218V)	2	Graphic EQ	Q2031B	3
Power Amp	P3500S	2	Monitor Speaker	SM12V (CM12V)	4		8ch Audio snake	1

Festival

This system is designed for optimum sound coverage from a central stage surrounded by the audience. Special attention must be paid to monitoring in this type of situation, so each performer is provided with his or her own monitor speaker. The MG166CX console provides ample mixing and signal-processing capability, while dual P5000S power amplifiers driving four S115V (C115V) speakers on stands effectively cover the required area. The built-in SPX digital effects make it convenient and easy to add high-quality reverb and delay for band performances.

System Chart

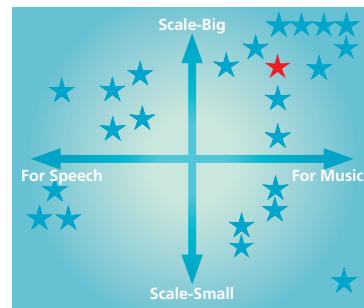

Mic:
1 ~ 10 channels
Line:
2 ~ 4 stereo
Scale:
Central outdoor stage
Audience:
100 ~ 300 people

Sample Application

Serving the entire area from a temporary central stage

Source

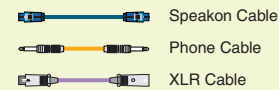
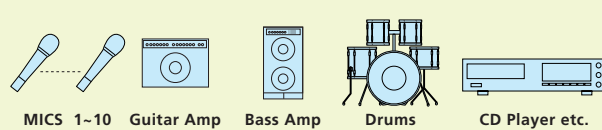

Good Reasons For Choosing Yamaha

Mixer

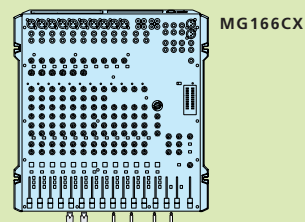

MG166CX

- MG166CX**
- Top-class SPX digital effect processor with 16 presets built in.
 - Selected parts and precision manufacturing deliver sound quality and performance you'd expect from top-line professional mixers.
 - Comprehensive output facilities for maximum system flexibility.
 - Slim, lightweight design is portable while being extremely rugged and reliable.
 - Yamaha 1-knob compressor on microphone inputs makes it easy to maximize the sonic impact of your mixes.
 - Rack mountable.

Signal Processor

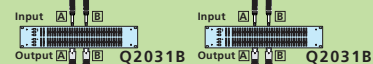

- Q2031B**
- Use both channels for feedback control and to deliver the optimum monitor sound.

Power Amp



- P5000S, P3500S**
- The P5000S is used to power the main speakers, and the P3500S drives the small stage monitors. YS Processing delivers optimum performance from the Club Series speakers.

Speaker

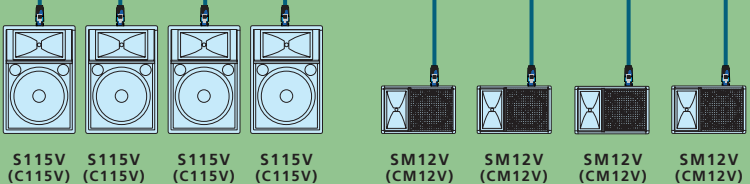

- S115V (C115V)**
- These speakers cover the entire service area from four points on the temporary stage. 15-inch woofers are chosen to ensure solid coverage.
- SM12V (CM12V)**
- Compact 12-inch monitors supply clear monitor sound to performers.

Equipment List

Mixer	MG166CX	1	Speaker	S115V (C115V)	4
Power Amp	P5000S	2	Monitor Speaker	SM12V (CM12V)	4
Power Amp	P3500S	4	Graphic EQ	Q2031B	2

County Fair

County fair type events combine announcements with competitions and music, requiring substantial sound-reinforcement capability. And since the area to be serviced can be quite large, ample power and coverage are essential. In this system, FOH power is supplied by P5000S amplifiers feeding dual-driver speaker systems for high efficiency. A solid 2.8 kilowatts is provided for monitoring via four SM12V (CM12V) monitor speakers. The MG24/14FX console can easily handle the wide range of sources this type of event can entail.

System Chart

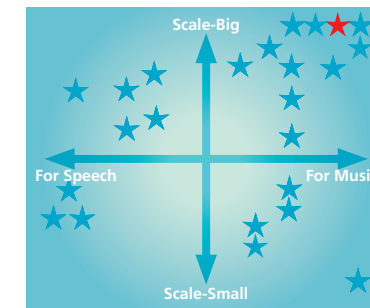

Mic:
1 ~ 16 channels
Line:
Four stereo
Scale:
Temporary outdoor stage. Contests being held in front of the stage with full-time announcements and commentator. Live music during breaks in the activities.
Audience:
500 ~ 1,000 people

Sample Application

A large-scale system to handle everything from announcements to live bands

Source

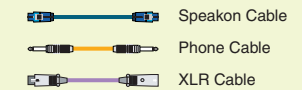
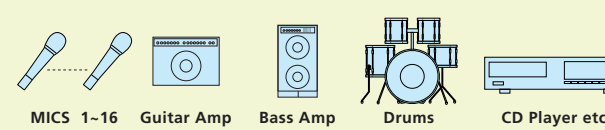

Good Reasons For Choosing Yamaha

Mixer

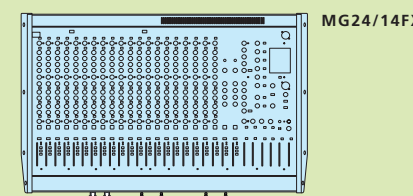

MG24/14FX

- MG24/14FX**
- 16 microphone inputs plus four stereo line inputs and built-in digital SPX effects.
 - Plenty of inputs and outputs for versatile system expansion
 - The MG24/14FX contain a powerful pair of Yamaha digital signal processors that provide a useful selection of 16 advanced digital effects.

Signal Processor

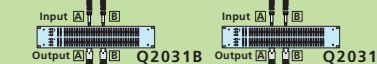

- Q2031B**
- Use both channels for feedback control and to deliver the optimum monitor sound.

Power Amp



- P5000S, P3500S**
- Delivering efficient power to the Club V-series speakers are the P5000S for FOH and the P3500S for the monitors.

Speaker

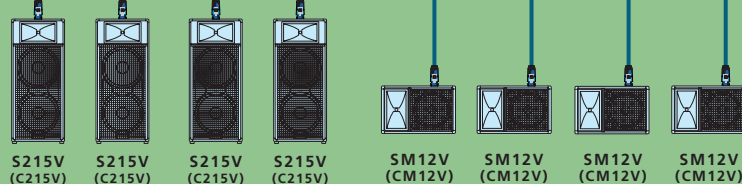

- S215V (C215V)**
- Two dual-woofer S215V (C215V) speakers ensure that the program reaches the entire audience in the outdoor application. An ideal setup for continuous use.
- SM12V (CM12V)**
- Compact 12-inch monitors put out focused stage monitor sound.

Equipment List

Mixer	MG24/14FX	1	Speaker	S215V (C215V)	4
Power Amp	P5000S	2	Monitor Speaker	SM12V (CM12V)	4
Power Amp	P3500S	4	Graphic EQ	Q2031B	2

Small Church

Designed primarily for background music and speech, this compact, easy-to-handle system is ideal for small houses of worship. It's portable and easily re-configurable, so it can easily be adapted to a variety of programs, indoors or out. An MG124C mixer offers advanced mixing potential and versatility in a space-saving package, and a P3500S power amplifier delivers more than enough ultra-clean power to make the most of the S112V (C112V) house speakers.

System Chart

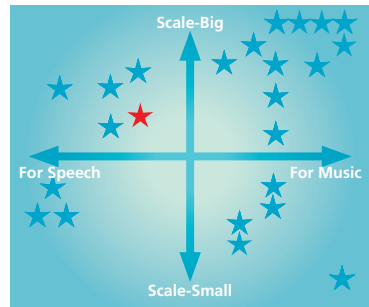

Mic:
1 ~ 6 channels
Line:
Four stereo
Scale:
Small town church
Audience:
Approximately 50 people

Sample Application

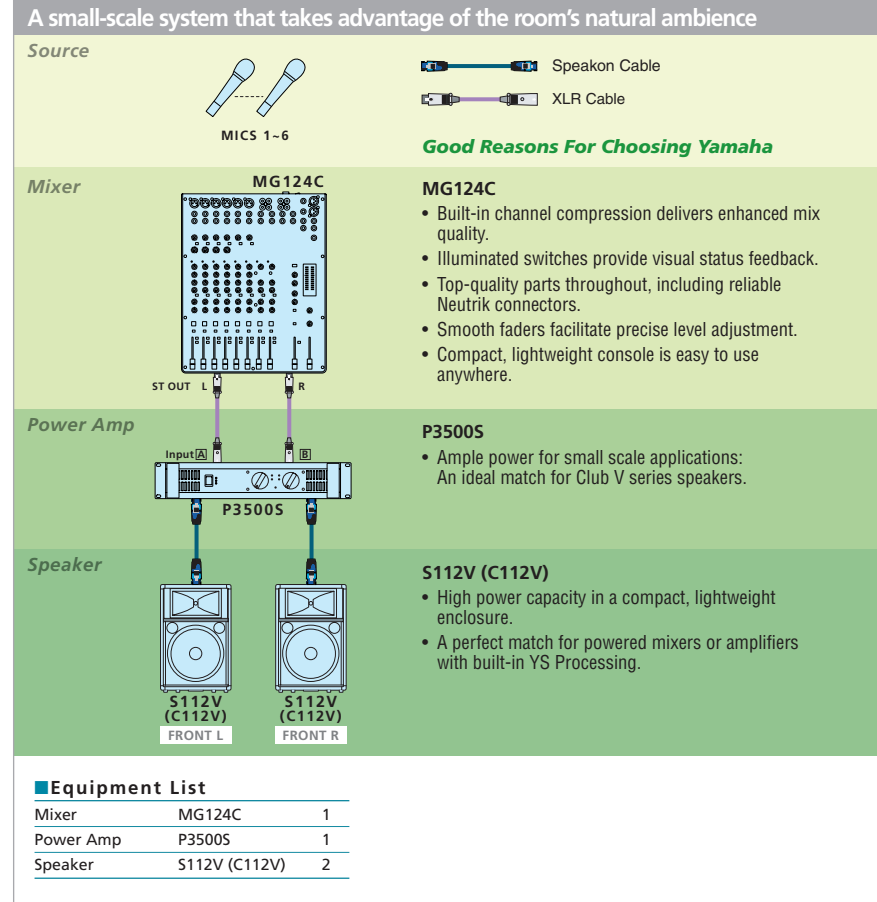

Mid-sized Church

A system like this is an excellent starting point for worship programs that involve live music as well as the spoken word. An MG166C console provides outstanding sonic quality and mixing flexibility. And an output chain consisting of P5000S power amps driving C115V (S115V) full-range speakers and CW118V (SW118V) subwoofers will get the musical message across without compromise. Powered monitor speakers such as the MSR100 can be added if monitoring is required.

System Chart

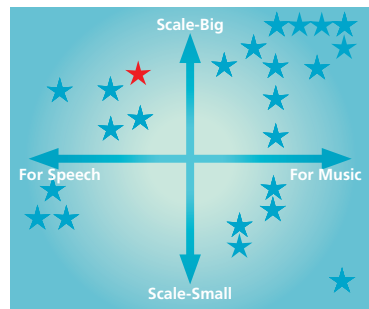

Mic:
1 ~ 10 channels
Line:
Four stereo
Scale:
Town church
Audience:
Approximately 100 people

Sample Application

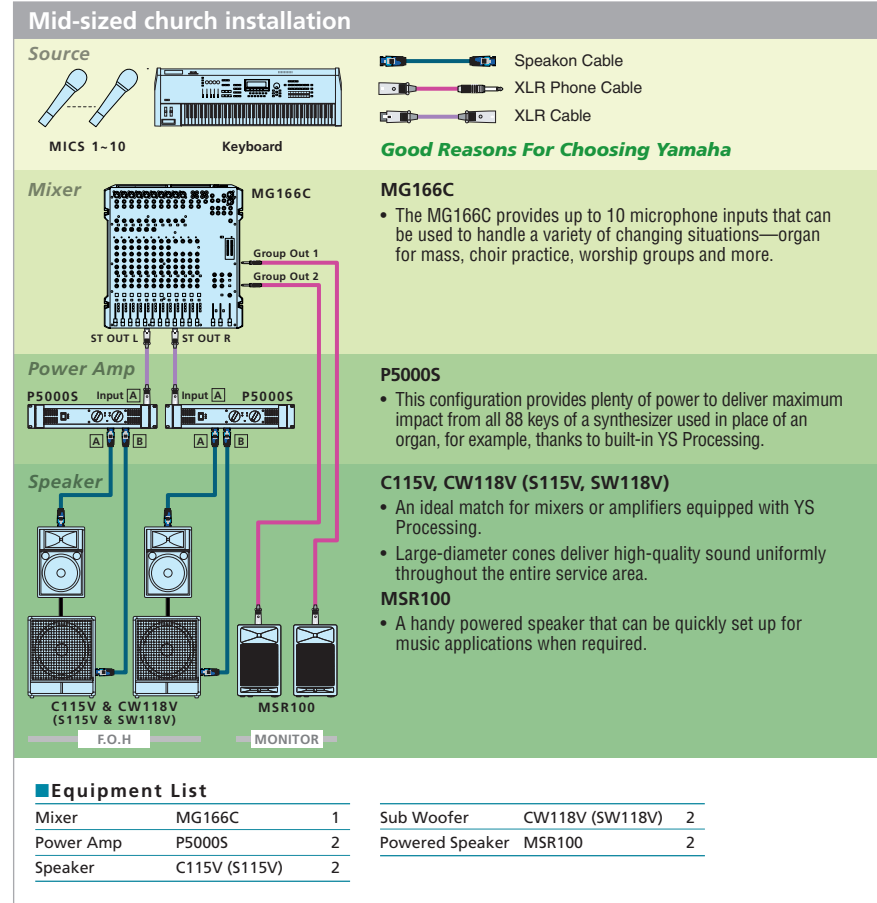

House of Worship Installation

In addition to handling church activities, this installation is designed to deliver the best possible sound for music and theatrical presentations as well. A 40-channel IM8-40 console ensures that plenty of I/O capacity is available for any type of event the church may be required to host. Four stage monitors are powered by a pair of P3500S amplifiers, while left and right mains with subwoofers plus flown center and side speakers deliver uniformly high quality sound throughout the house. The mono-fed center speaker is particularly important in achieving maximum clarity and intelligibility for sermons and speeches, while the subwoofers deliver maximum musical impact. The console's matrix is used to provide sound for the foyer, dressing rooms, and other remote locations via a P2500S amplifier with output transformers and appropriate ceiling-mounted speakers. A computer running the supplied Cubase AI4 digital audio workstation software can be connected to the console's USB I/O port for recording and playback as required.

Sample Application

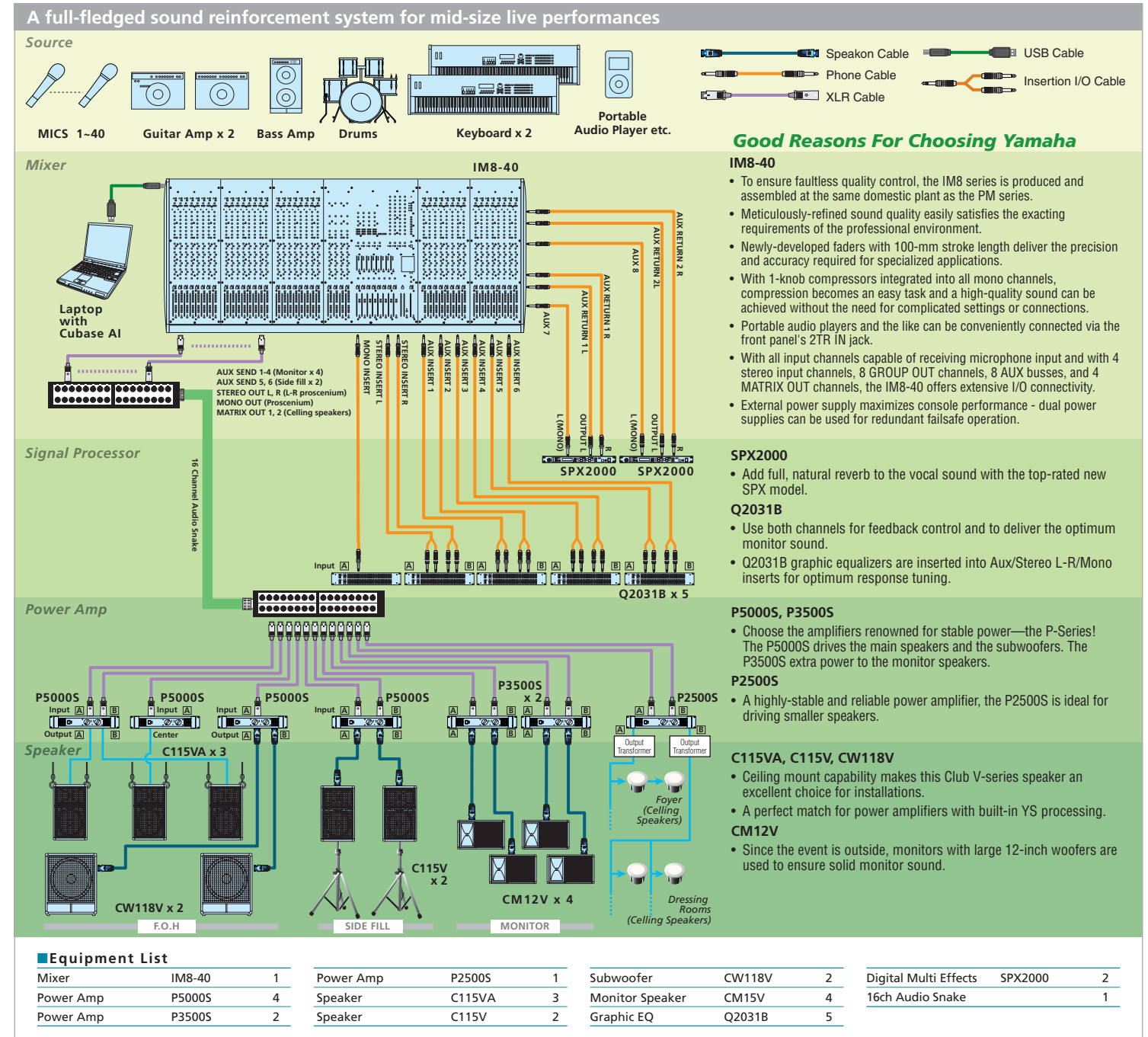

Tips 1

PA Basics

The term "PA" traditionally stands for "Public Address," and "PA System" refers to an electronic system for amplifying the voice of a speaker addressing a large crowd or people distributed throughout a large building. These days the term is often applied to the main amplification system at events and concerts as well, although such systems are sometimes called "sound reinforcement systems," or simply "sound systems."

The main functions of a PA or sound reinforcement system are summarized below:

Input

- The sound from acoustic sound sources such as speech or singing, drums, pianos, acoustic guitars, and electric guitar amplifiers is initially picked up using microphones. Microphones sources are input to the sound system's mixer via its microphone or "mic" inputs.
- The output from electronic sources such as CD players, synthesizers, and other electronic instruments are connected directly to the mixer via its line inputs.



Mixing and Processing

- As its name implies, a "mixer" is a device which is used to mix and balance the signals from the various microphone and line sources to create the final program the audience will hear. The mixer usually also includes equalization facilities.
- Some mixers also include effects such as reverb or delay to allow more extensive control over the output sound.

Amplification

- The balanced program created by the mixer is sent to a power amplifier which boosts the program signal so that it can drive the system's speakers.
- Although separate power amplifiers can be used in just about any application, mixers with built-in power amplifiers and powered speakers are often a better choice especially when system simplicity and portability are required.



Delivery

- The output from the power amplifier (whether separate or built-in) drives the speakers that actually deliver audible sound to the audience. The type and number of speakers required will depend on the size and configuration of the venue as well as the type of event being handled.
- In live music applications monitor speakers for the performers will also be necessary in most cases.

Live Music at Home

Here's a system that will be appreciated by individuals or families who enjoy live music at home. Although an electronic keyboard and just a couple of microphones are shown, this setup can handle quite a bit more. The MG124CX console will handle up to 12 inputs with top-quality effect processing built-in, and a pair of MSR100 powered speakers put out sound adequate for all but the most spacious living rooms.

System Chart

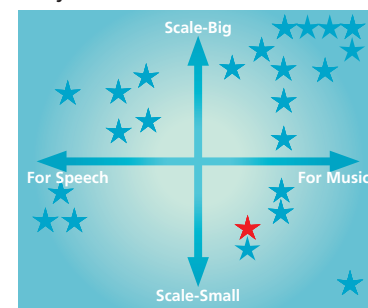

Mic:
1 ~ 6 channels
Line:
Four stereo
Scale:
Living room
Audience:
10 ~ 15 people

Sample Application

The perfect setup for solo performances at home

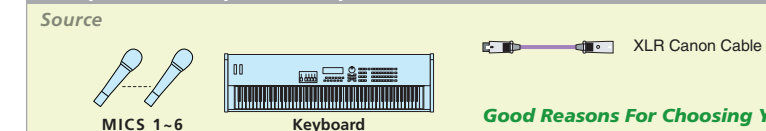

Good Reasons For Choosing Yamaha

- Mixer**
- MG124CX**
- Built in channel compression makes it easy to achieve great vocal or guitar sound.
 - Renowned Yamaha SPX effects built in.
 - Compact, lightweight design lets you make music just about anywhere.

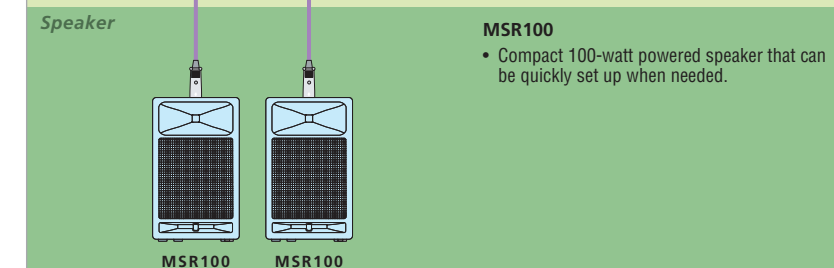

Equipment List

Mixer	MG124CX	1
Powered Speaker	MSR100	2

Mixer Essentials

The mixer is the core of any sound system. The basic elements of a mixer are described below, using the simple MG102C mixer as an example.

MIC
These are the mixer's microphone inputs, featuring top-quality Neutrik XLR type connectors. The MG102C allows connection of up to four microphones.

LINE
Electronic keyboards and other electronic instruments, effect devices, electric-acoustic guitars and other line-level devices can be connected to the LINE inputs. Both mono and stereo line inputs are provided, so synthesizers with stereo outputs, for example, can be connected to the stereo line inputs.

GAIN
Primarily used to adjust the input gain (sensitivity) of the microphone inputs. Microphone signals are much lower in level than line signals, and require extra amplification.

HIGH/MID/LOW (Equalizer) /HIGH/LOW
These equalization controls—somewhat similar to tone controls—can be used to refine the sound of each individual channel. Independent controls for the high, midrange, and low frequencies allow precise response shaping.

AUX
In addition to the main stereo program outputs, the mixer has "auxiliary" outputs that can be used to send the channel signals to external signal processors or monitor amps and speakers. Independent AUX controls are provided for each channel.

PAN
These controls position the corresponding channel's signal from left to right in the stereo sound field. "Pan" is short for "panorama" or "panoramic" control.

LEVEL
These are the main level controls for each of the mixer's channels. The MG102C uses rotary level controls. On larger mixers these are often linear "faders".

Pin-jack Connectors
These are line-level inputs provided specifically for connecting to standard CD players or tape decks and thus feature pin-jacks that are directly compatible with most equipment of this type.

2TR IN
These inputs are primarily used to receive the stereo signal from a CD player or other source for background music.

REC OUT
The REC OUT connectors can be connected to a stereo tape deck or other recording device to allow convenient recording of the mixer's stereo program.

STEREO OUT
These are the mixer's main stereo program outputs.

SEND
Sends the assigned signals to an external signal processing device or monitor system.

RETURN
Receives the processed signal returned from an external signal processing device to be mixed back in with the program signal.

METER
Allows accurate visual monitoring of the mixer's stereo signal levels.

ST
Adjusts the level of the mixer's STEREO outputs, and thus the volume of the sound heard from the system's speakers.

MONITOR/PHONES
This control adjusts the signal level monitored via both headphones and the mixer's MONITOR outputs.

Wedding Ceremony

Two elements essential to any wedding (in addition to the bride and groom) are speech and music. This system is ideal when the joyous mood of the moment needs to be conveyed to a fairly large group of guests. In most cases, just a couple of microphones are sufficient, and an electronic keyboard such as one of Yamaha's superlative MOTIF series can function as pipe organ, piano... just about any instrumentation you need. An EMX312SC driving a pair of S115V (C115V) speakers for FOH, and an SM12V (CM12V) for monitoring should cover the sound delivery requirements.

System Chart

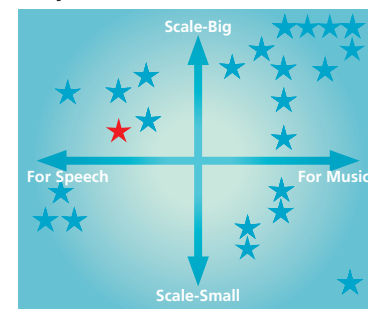

Mic:
1 ~ 8 channels
Line:
Four stereo
Scale:
Wedding chapel with central aisle
Audience:
20 ~ 30 people

Sample Application

A mid-size system to complement important celebrations

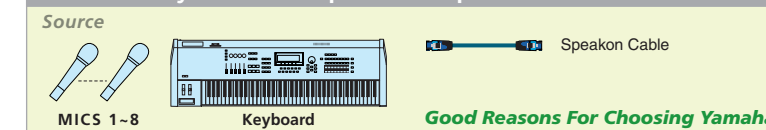

Good Reasons For Choosing Yamaha

- Mixer**
- EMX312SC**
- This powered mixer ensures that speeches, background music, and keyboard (organ) performances are heard by everyone present.
 - Graphic EQ can be put to good use in adjusting for optimum sound in naturally reverberant chapel spaces.
 - The microphone inputs can also be used for speeches by guests.
 - FCL helps to keep feedback in check even when the M.C. moves around.

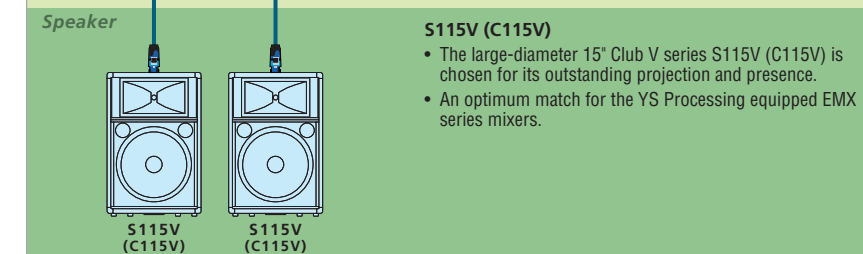

Equipment List

Powered Mixer	EMX312SC	1
Speaker	S115V (C115V)	2

Tips 2

Although a PA system's mixer, amplifiers and speakers are indispensable, so are the cables and connectors that get the system's signals from one place to another. In fact, choosing the right cables for the various system connections is of the utmost importance. Here's a brief overview of the main types of cables and connectors you are likely to encounter.

1. Cable Types

Microphone/Line Cables

These are the cables used to connect microphones and electronic instruments to the mixer's inputs, and connect the line-level signal from the mixer's outputs to the system's power amplifier(s). These types of cables are shielded to minimize noise pickup.

* Never use this type of cable to connect the outputs of a power amplifier to speakers. Microphone/line cables are designed to handle low-level signals, and heat up and even pose a fire hazard if used for power connections.



Unbalanced Cables

Unbalanced cables have just two conductors—generally a core and a shield. Electric guitar cables and most types of electronic instrument cables have this type of construction. Cables of this type are convenient to use and offer good noise rejection, but are inferior to balanced cable when it comes to noise-rejection with very low-level signals or long cable runs.

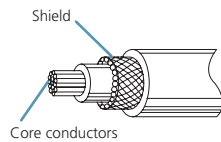

Balanced Cables

Balanced cables have three conductors—two core conductors surrounded by a shield. This type of connection was invented to overcome the noise pickup problems commonly encountered with unbalanced connections, and is the type used in most professional sound equipment. This type of cable can only be used with balanced connectors.

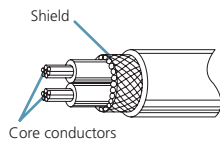

Speaker Cables

Speaker cable is specifically designed to transfer the amplified signal from the power amplifier's outputs to the speaker's inputs. Speaker cables feature heavy-duty conductors designed to handle the high-power signal delivered by the power amplifier, and because of the much higher signal levels no shield is required.

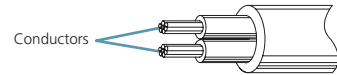

* Speaker cable cannot be used in place of microphone/line cable because of its susceptibility to noise pickup.

Maximum Cable Length

The maximum usable length of a cable will depend on the output impedance of the device feeding it. The maximum length of cable that can be used with high-impedance outputs is about 10 meters. For low-impedance outputs, the maximum is about 20 meters with unbalanced cable or 80 meters with balanced cable. Longer cables will probably cause some signal degradation, particularly a loss of the high frequencies. (The actual maximum length will also depend on the construction and quality of the cable.)

2. Connector Types

Phone Connectors

The name "phone connector" (phone plugs and phone jacks) comes from the fact that these connectors were originally used in telephone switchboards. Phone connectors come in mono and stereo types. The stereo type is also sometimes referred to as a "TRS" (Tip, Ring, Sleeve) phone connector, and these types can be used for headphones and other stereo signal connections, input/output insert patching, and balanced signals. Mono types are only used for unbalanced connections, and are commonly used for guitar and instrument cables.

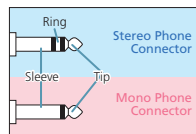

RCA Pin Connectors

Most home-use audio and audio/video equipment use this type of unbalanced connector. The connectors are often color-coded according to the type of signal they carry: white for the left audio channel, and red for the right audio channel.



XLR-type Connectors

These connectors are primarily used for balanced connections. These are the connectors of choice for most professional applications because the connectors themselves are extremely durable and reliable, and some feature a locking mechanism to prevent accidental disconnection. Normally "male" connectors are used for outputs and "female" connectors are used for inputs.



Speakon Connectors

This is a relatively new type of connector that is becoming widely used for speaker connections in professional applications. This type of connector features easy connection as well as high reliability.



Dinner Presentation

For formal or informal gatherings that require only a few microphones for speech and an electronic musical instrument or two, a system like the one shown here should be more than sufficient.

With the STAGEPAS 250M, you get a portable PA system comprising a stereo powered mixer, a high-quality speaker, and a speaker cable. As such, it is the ideal choice for speeches, dinner presentations, and other basic PA applications. The default mono specification of the STAGEPAS 250M is all you will need to amplify spoken word, and if you need to also handle stereo music playback or instruments, an MSR250 speaker can be added to realize a flexible stereo PA system.

System Chart

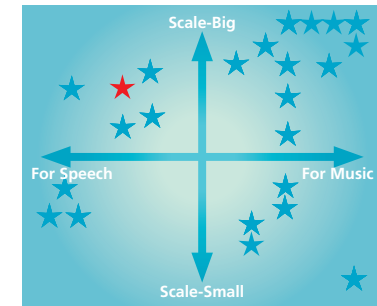

Mic:
1, 2 channels
Line:
1 ~ 4 stereo
Scale:
Large room or restaurant with dinner tables
Audience:
Approximately 50 people

Sample Application

An ideal small system for presentations to small groups

Source

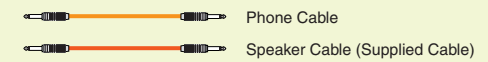

Mixer

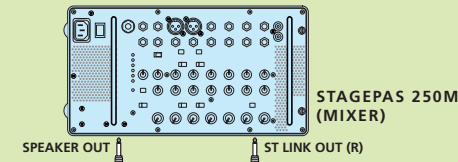

Good Reasons For Choosing Yamaha

- STAGEPAS 250M (MIXER)**
- Remarkably compact and lightweight.
 - Mixer settings and sound quality can be adjusted to best suit the current application using a SPEECH/MUSIC switch.
 - The sound can be further adjusted through the use of limiting, which suppresses excessive input signals, and compression, which adds more punch to the mix.
 - Optional BMS-10A Mic Stand Adaptor allows microphone-stand mounting for easy placement and access.
 - The mixer also includes a high-grade reverb effect, lauded for its professional-sounding ambience.

Speaker

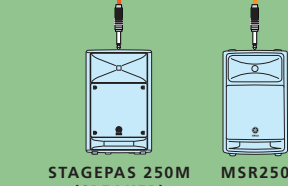

- STAGEPAS 250M (included speaker)**
- As a 10-inch, two-way, bass-reflex type speaker, the STAGEPAS 250M delivers a powerful, high-quality sound.
 - In order to suit all possible types of application, the speaker has been designed to be stood upright, laid on its side as a foldback monitor, or even mounted on a microphone stand (sold separately).
- MSR250**
- Powerful Max. 250-watt output and outstanding sound quality from compact, lightweight powered speakers. Ideal for front-of-house sound as well as monitoring.
 - Speaker Stand Mountable (Speaker Stand is optional).

Equipment List

Portable PA System	STAGEPAS 250M	1
Speaker	MSR250	1

1 Simple Steps To Better Sound

Gain is the key to level control

The role of a sound system is basically to mix and amplify multiple sources to the required level. Learning to set appropriate levels is vitally important to achieving the best possible sound quality.

Mixer

1. The most important level adjustment is gain control. For the best mix and sound, the gain of individual channels should be as high as possible without distorting or clipping the signal. Some basic levels are given in the chart below.
If your mixer has peak indicators, gain should be set so that they light only occasionally on brief signal peaks.
2. Set the master fader about three-quarters of the way toward its maximum setting.
3. Use the channel faders to set the balance between the input sources. Watch the level meters while doing this, and try to set the overall mix so

that the meters just reach peak level on the highest peaks that will be encountered during the program.

Gain Setting Guide

Microphone:	Speech	-50dB
Microphone:	Soft Vocal	-50dB
Microphone:	Loud Vocal	-40dB
Cassette/VTR		-10dB
CD/LD		0dB

Power Amps

Turn the amplifier's attenuator or volume control up to the required level. The important thing to remember is that you should not move the mixer's master fader at this point. Use the power amplifier controls to set the overall level. In powered mixers, however, the master fader doubles as the power amp attenuator, and can be used to set the overall volume.

Outdoor Dance Event

This relatively large system is designed to deliver dynamic full-spectrum sound that will keep dancers and revelers on the floor. The high-capacity MG32/14FX console comfortably handles a wide range of sources and signal-processing, while four P5000S power amplifiers driving four S215V (C215V) speakers and SW118V (CW118V) subwoofers lay down sound the dancers will delight in. Monitor sound is delivered via P3500S amps and SM12V (CM12V) monitor speakers, and graphic EQ for feedback control.

System Chart

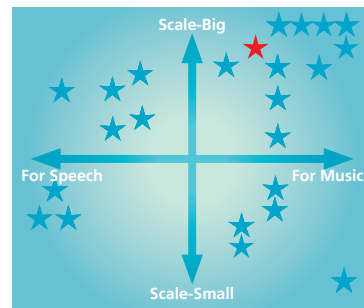

Mic:
1 ~ 24 channels
Line:
Four stereo
Scale:
Public area with stage set up for music and a dance floor
Audience:
500 people—audience and dancers

Sample Application

Large-scale support for outdoor school festivals or dance events

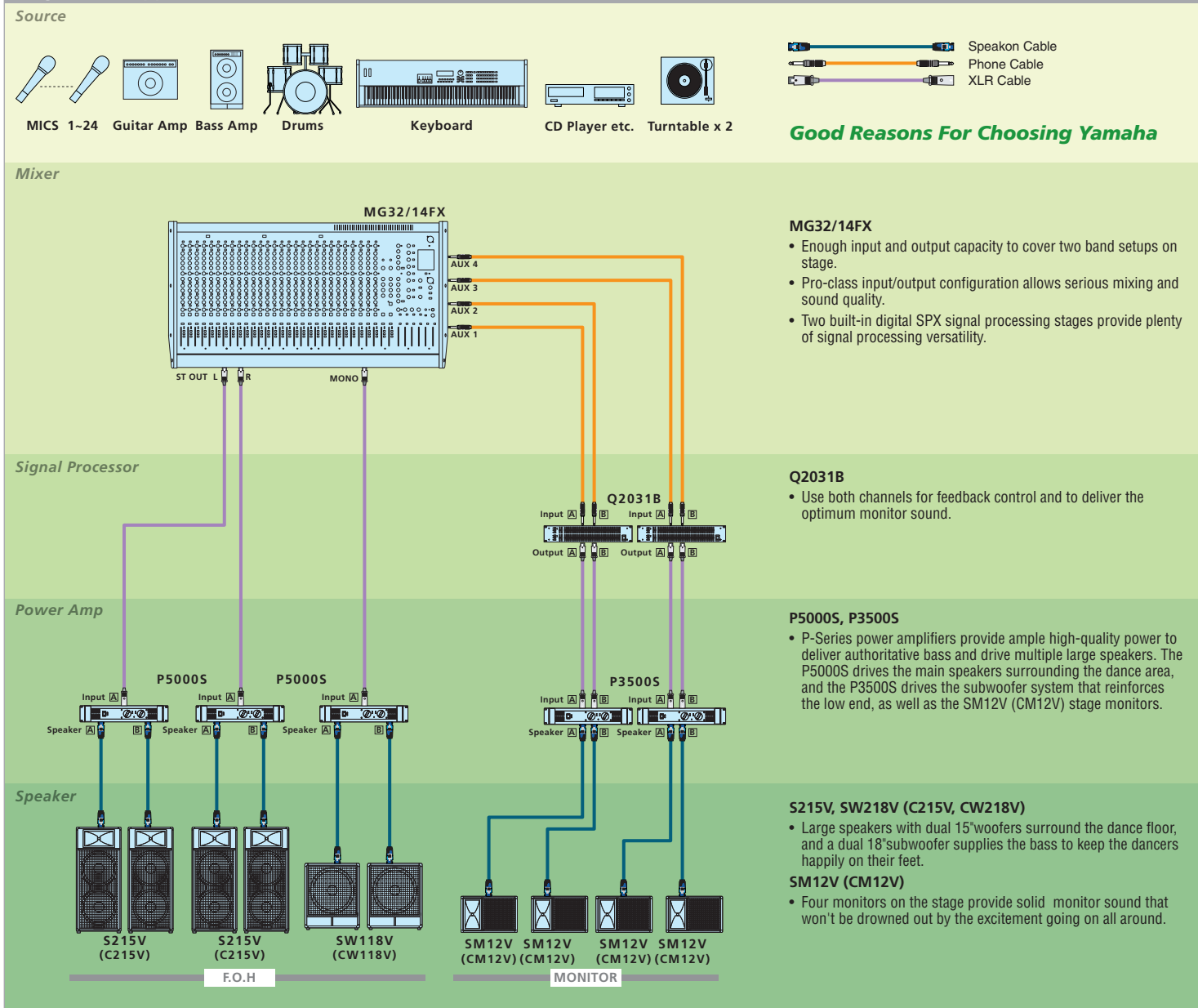

Equipment List					
Mixer	MG32/14FX	1	Graphic EQ	Q2031B	2
Power Amp	P5000S	3	Speaker	S215V (C215V)	4
Power Amp	P3500S	2	Woofer	SW118V (CW118V)	2
			Monitor Speaker	SM12V (CM12V)	4

Acoustic Music

Acoustic instruments often need amplification to be heard and appreciated by more than a handful of people. Here's a little system that is ideal for such applications, with room to spare. Plug your electric-acoustic guitars and microphones into an EMX212S powered mixer that directly drives a pair of BR10 speakers.

System Chart

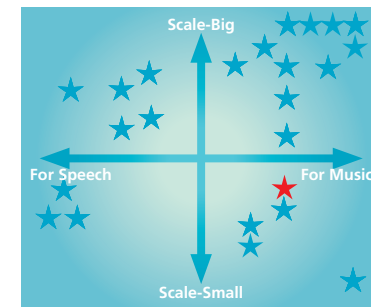

Mic:
1 ~ 8 channels
Line:
Four stereo
Scale:
A room about the size of a high-school classroom
Audience:
10 ~ 20 people

Sample Application

A small system with superior portability and handling ease

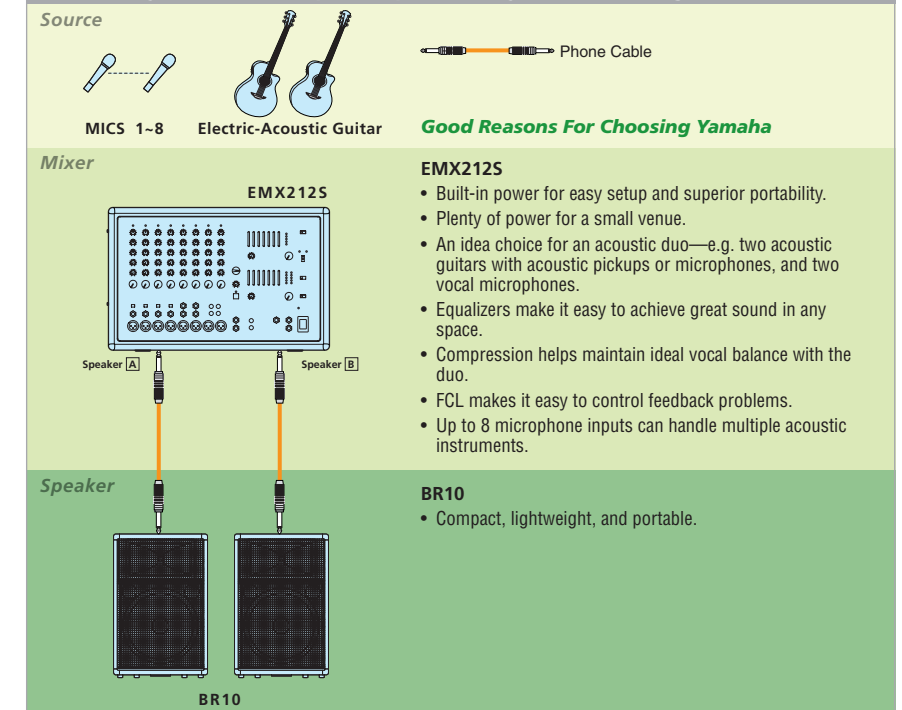

Equipment List

Powered Mixer	EMX212S	1
Speaker	BR10	2

Conference Room

The system shown here can deliver both optimum speech intelligibility for meetings as well as quality music reproduction for breaks. The compact MG166C-USB mixer is a perfect choice for this type of application, with enough capacity and control features to cover just about any conceivable situation. This system allows extra audience microphones to be provided, and Q&A sessions can be easily recorded to the computer.

System Chart

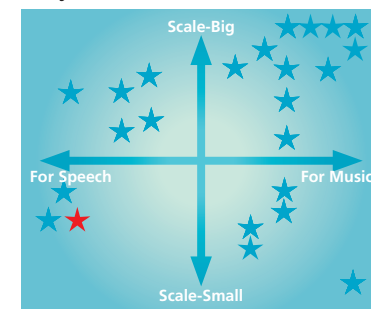

Mic:
1 ~ 10 channels
Line:
2 ~ 4 stereo
Scale:
Meeting or presentation room
Audience:
20 ~ 30 people

Sample Application

The perfect small setup for meetings and presentations

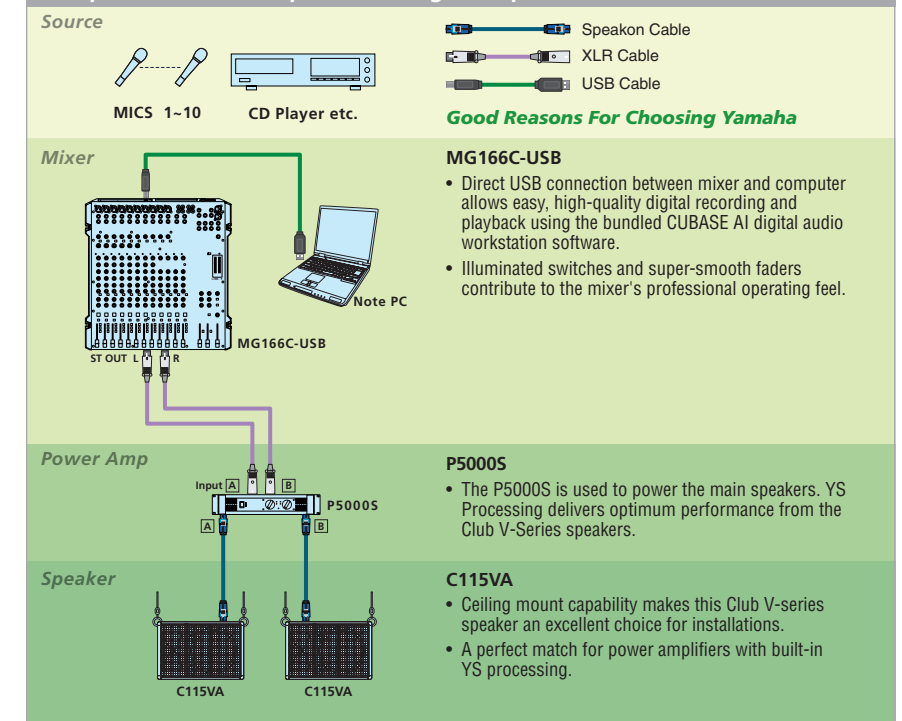

Equipment List

Mixer	MG166C-USB	1
Power Amp	P5000S	1
Speaker	C115VA	2

Lecture Hall

Lecture hall sound systems require a surprising degree of functionality—in addition to microphones, there are tape and disc audio sources, audio from a video projector, and computer sound output for OHP presentations. The MG206C-USB mixer shown in this example is large and versatile enough to handle all of the above and more. And a pair of C115V (S115V) powered speakers delivers enough power and quality to project the sound to the highest tier in the room. This system allows extra audience microphones to be provided, and Q&A sessions can be recorded to the computer. Recorded material can be easily turned into podcasts for distribution.

System Chart

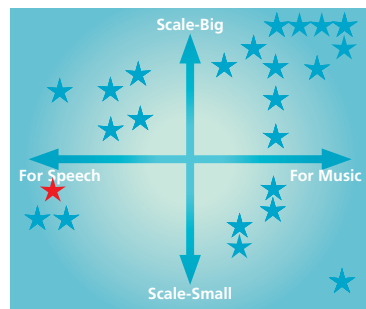

Mic:
1 ~ 16 channels

Line:
1 ~ 4 stereo

Scale:
College lecture hall

Audience:
50 ~ 100 people

Sample Application

Small but powerful for lectures and addresses

Source
MICS 1-16 CD Player etc.

Mixer
MG206C-USB

Power Amp
P7000S

Speaker
C115V (S115V)

Good Reasons For Choosing Yamaha

MG206C-USB

- Direct USB connection between mixer and computer allows easy, high-quality digital recording and playback using the bundled CUBASE AI digital audio workstation software.
- Illuminated switches and super-smooth faders contribute to the mixer's professional operating feel.
- Extra input channel capacity means that more microphones can be used wherever they are required.

P7000S

- The P7000S is used to power the main speakers. YS Processing delivers optimum performance from the Club V-Series speakers.

C115V (S115V)

- A perfect match for power amplifier with built-in YS Processing.

Equipment List

Mixer	MG206C-USB	1
Power Amp	P7000S	1
Speaker	C115V (S115V)	2

Point of Sale

There are a multitude of uses for small PA systems in markets and malls. A small mixer, a single microphone, and either the MSR100 or MS101III powered speaker are all you need for a basic system, but you could add a CD player or other music source for BGM as required. Yamaha's 1-knob compressor can help to achieve maximum intelligibility and projection.

System Chart

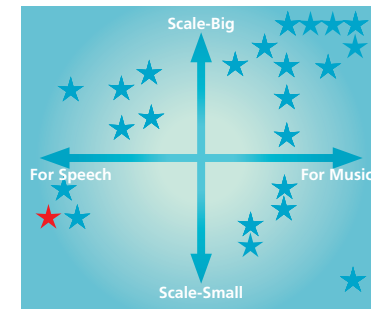

Mic:
1 ~ 4 channels

Line:
2 ~ 4 stereo

Scale:
Large room or restaurant with dinner tables

Audience:
Approximately 50 people

Sample Application

Small, simple, and portable for point-of-sale use

Source
MICS 1-4 CD Player

Mixer
MG102C

Speaker
MSR100 or MS101 III

Good Reasons For Choosing Yamaha

MG102C

- Built-in channel compression aids in achieving optimum intelligibility with fewer level fluctuations.
- Compact, lightweight design means the mixer can be used anywhere and easily moved around as required.
- Optional BMS-10A Mic Stand Adaptor allows microphone-stand mounting for easy placement and access.

MSR100 or MS101 III

- High-power 100-watt speaker with direct microphone and line inputs (MSR100).
- Plug a microphone directly into the front-panel mic jack (MS101 III).
- Just one speaker and a CD player lets you provide background music.
- All you need is a power outlet and it's ready to use.

Equipment List

Mixer	MG102C	1
Powered Speaker	MSR100 or MS101 III	2

Gymnasium

In addition to sports events, the "gym" also serves as a venue for gatherings, meetings, and even movies and concerts. Plenty of PA power and mix capacity is required to cover all possibilities. Here's a system that will do the job nicely without being excessive: an EMX5014C powered mixer driving a pair of BR15 speakers. Superb quality and useful capacity without a lot of extra equipment.

System Chart

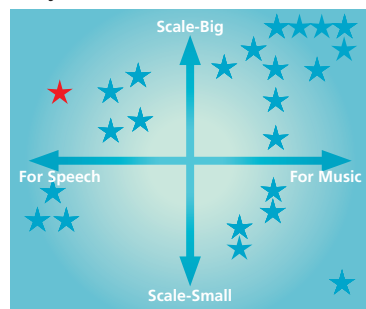

Mic:
1 ~ 8 channels

Line:
Four stereo

Scale:
Gymnasium

Audience:
100 ~ 200 people

Sample Application

A mid-size system for sports and other gym events

Source
MICS 1-8 CD Player etc.

Mixer
EMX5014C

Speaker
BR15

Good Reasons For Choosing Yamaha

EMX5014C

- Versatile mixing capability and high power amplification built into a portable unit.
- Sufficient power for even large gymnasiums.
- Plenty of input capacity to handle instruments for live music.
- One-knob Compression makes it easy to set up optimum microphone sound.
- Versatile equalization and built-in SPX digital effects offer extensive creative control.
- FCL makes it easy to control feedback problems.

BR15

- The same large-diameter 15" drivers that have made the Club Series speakers leaders in their class.
- Durable carpet finish withstands rough use.

Equipment List

Powered Mixer	EMX5014C	1
Speaker	BR15	2

2 Simple Steps To Better Sound

Connection and power switching order

Although simple, the following points will help you to keep your speakers and sound gear in top condition for as long as possible.

Connecting Cables

Always make sure that all equipment is turned off when making connections. Also make sure that all volume and level controls are turned down to minimum before turning the power on.

Power ON/OFF Switching

When turning on the power to your system, follow the procedure outlined below to protect your speakers from the power surge that occurs when sound gear is switched on or off.

1. Turn on electric/electronic musical instruments and sources such as CD or cassette players
2. Turn on the mixer
3. Turn on any graphic equalizers
4. Turn on the power amp(s)

Reverse this procedure when turning the system off. See "Simple Steps To Better Sound - 2" for information on preventing speaker overload and "Simple Steps To Better Sound - 3" for feedback control hints.

3 Simple Steps To Better Sound

Feedback control

Piercing squeals of feedback can put a damper on even the finest performance. Feed back control is a vitally important part of live sound.

1. Check the relative positions of microphones and speakers—feedback is caused by sound from the speakers being picked up again by the microphones and "re-circulated". In many cases, feedback can be eliminated simply by adjusting the positions of the speakers and microphones. Hand-held microphones require extra care so that the performer doesn't move into the "feedback zone".

2. Use graphic EQ. If speaker and microphone positioning doesn't solve the problem, use some graphic equalization. Begin by bringing the mixer levels up to a point just before feedback begins—raise the microphone-input channel faders and then raise the master fader until feedback begins, then back off a bit. Start with the graphic EQ controls flat (set at "0") and, starting with the lowest frequency, raise each control a few dB. If no feedback occurs, return the controls to "0" as you test each frequency. If feedback occurs when you boost one frequency, cut that frequency by a few dB, and continue testing the remaining frequency bands. This procedure can be effective in preventing feedback in situations in which the microphones and monitor speakers must be used in close proximity.

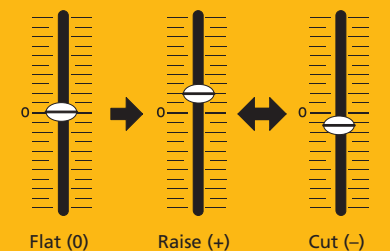

A complete PA system designed from the start for portability and convenience

STAGEPAS 300

- Perfect for public speaking, vocalists, guitarists... just about any performance or event requiring portability and convenience combined with superior sound and versatility.
- Eight-channel powered mixer with four microphone and two stereo line inputs, 150W + 150W power, and digital reverb.
- High-performance two-way bass-reflex speakers double as convenient storage for mixer and cables... with enough room left over for microphones and other articles you might need.
- The powered mixer can be operated while mounted in the speaker cabinet, or separated for versatility and easy access.
- Optional BMS10A Mic Stand Adaptor allows the mixer to be mounted on a mic stand.



Extra Power and Capacity for Larger Venues

STAGEPAS 500

- Dual 250-watt power amplifier can fill surprisingly large clubs or rooms, or project your sound over a considerable distance outdoors. Class-D power delivers superior sound quality as well as reliability in a remarkably compact unit.
- 10 input channels in all: four mono microphone/line inputs and three stereo line inputs. Switchable phantom power is provided for high-performance phantom-powered condenser microphones, and top-quality Yamaha SPX reverb is built in.
- Channels 1 and 2 feature LIMIT/COMP switches that let you apply either limiting or compression to those channels.
- STAGEPAS 500 speakers can be stand-mounted without standard adaptors.



An ideal choice for amplifying keyboards, guitars, and bass, Yamaha's STAGEPAS series of single-speaker systems is also perfect for small-venue PA

STAGEPAS 150M

- Keyboard players and drummers can use the Click Assign switches to route a metronome or source from a main PA mixer via channel 5/6 (or channel 7/8 on the 250M) to headphones and a STAGEPAS speaker. The system's full-range speaker can be stood upright, laid on its side as a foldback monitor, or mounted on a speaker stand (using a separately-sold adaptor) to suit all possible types of installation. And if necessary, an MSR100 speaker can be added to realize a stereo system.
- Flexible 8-channel Powered Mixer
 - Detachable Powered Mixer
 - 150 Watt Class D Power Amplifier
 - Two-way Full-range Speaker System
 - Built-in EQ and 1-bit Modulation Reverb
 - MIC/LINE switches select microphone or line level input matching for channels 1 and 2.



STAGEPAS 250M

- Not only keyboard players and drummers, but also singers accompanying themselves on an electric-acoustic guitar are well served by this system. Boasting a full range extending into crystal-clear high frequencies, the STAGEPAS 250M can be stood upright, laid on its side as a foldback monitor, or mounted on a speaker stand to suit all possible types of installation. What's more, an MSR250 speaker can be added to provide support for stereo playback.
- Versatile 10-channel Powered Mixer
 - Detachable Powered Mixer
 - 250 Watt Class D Power Amplifier
 - Two-way Full-range Speaker System
 - Built-in EQ and High-quality Digital Reverb
 - Channels 1 and 2 feature LIMIT/COMP switches that let you apply either limiting or compression to those channels.
 - Pole mount receptacle for direct speaker stand mounting

System Chart

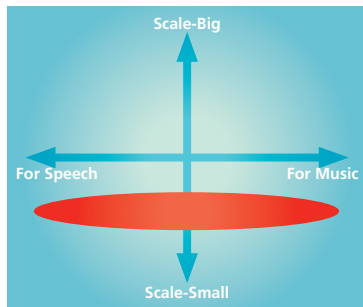

Mic: Four inputs
Line: Two stereo
Scale: —
Audience: 10 ~ 50 people

System Chart

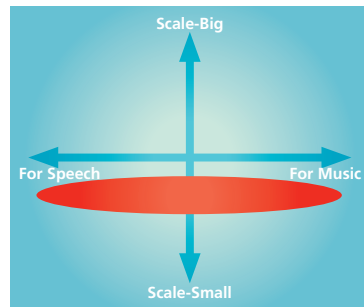

Mic: Four inputs
Line: Three stereo
Scale: —
Audience: 50 ~ 100 people

System Chart

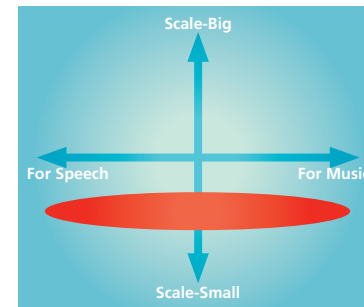

Mic: Two inputs
Line: Three stereo
Scale: Keyboard Amp/Monitor
Audience: —

System Chart

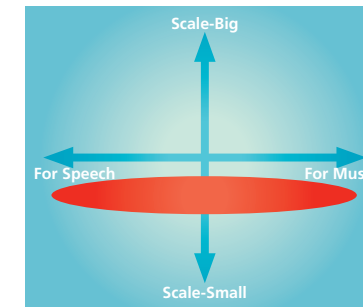

Mic: Two inputs
Line: Four stereo
Scale: Electric-Acoustic Guitar Amp/Monitor
Audience: —

Sample Application

<p>A complete PA system designed from the start for portability and convenience</p> <p>Source: MICS 1-4, Keyboard, Speaker Cable (Supplied)</p> <p>Good Reasons For Choosing Yamaha</p>	<p>Extra Power and Capacity for Larger Venues</p> <p>Source: MICS 1-4, Keyboard, Speaker Cable (Supplied)</p> <p>Good Reasons For Choosing Yamaha</p>						
<p>Mixer & Speaker</p> <p>STAGEPAS 300</p> <ul style="list-style-type: none"> • Portability and convenience. • 150W + 150W powered mixer. • Eight-channel mixer. • Hi performance two-way bass-reflex speaker. • Five meter speaker cables included. 	<p>Mixer & Speaker</p> <p>STAGEPAS 500</p> <ul style="list-style-type: none"> • High power but portable and easy to use. • Efficient, high-performance 250W + 250W amplifier. • Versatile 10-channel mixer with phantom power. • Compression/limiting and SPX reverb built in. • STAGEPAS 500 speakers can be stand-mounted without standard adaptors. 						
<p>Equipment List</p> <table border="1"> <tr> <td>Portable PA System</td> <td>STAGEPAS 300</td> <td>1</td> </tr> </table>	Portable PA System	STAGEPAS 300	1	<p>Equipment List</p> <table border="1"> <tr> <td>Portable PA System</td> <td>STAGEPAS 500</td> <td>1</td> </tr> </table>	Portable PA System	STAGEPAS 500	1
Portable PA System	STAGEPAS 300	1					
Portable PA System	STAGEPAS 500	1					

Sample Application

<p>Comprehensive keyboard amp for keyboard players</p> <p>Source: MICS 1-2, Keyboard, Speaker Cable (Supplied), Phone Cable</p> <p>Good Reasons For Choosing Yamaha</p>	<p>Busking amp for the solo performer</p> <p>Source: MICS 1-2, Electric-Acoustic Guitar, Speaker Cable (Supplied)</p> <p>Good Reasons For Choosing Yamaha</p>						
<p>Mixer & Speaker</p> <p>STAGEPAS 150M</p> <ul style="list-style-type: none"> • Portability and convenience. • 150W powered mixer. • Eight-channel mixer. • High performance two-way bass-reflex speaker. • Auto Limiter prevents overload damage to power amplifier and speakers. • Click Assign switch allows metronome or any source to be routed to monitor speaker and headphones for monitoring purpose. • Five meter speaker cable included. 	<p>Mixer & Speaker</p> <p>STAGEPAS 250M</p> <ul style="list-style-type: none"> • High power but portable and easy to use. • Efficient, high-performance 250W amplifier. • Versatile 10-channel mixer with phantom power. • Compression/limiting and SPX reverb built in. • STAGEPAS 250M speaker can be stand-mounted without standard adaptors 						
<p>Equipment List</p> <table border="1"> <tr> <td>Portable PA System</td> <td>STAGEPAS 150M</td> <td>1</td> </tr> </table>	Portable PA System	STAGEPAS 150M	1	<p>Equipment List</p> <table border="1"> <tr> <td>Portable PA System</td> <td>STAGEPAS 250M</td> <td>1</td> </tr> </table>	Portable PA System	STAGEPAS 250M	1
Portable PA System	STAGEPAS 150M	1					
Portable PA System	STAGEPAS 250M	1					

Product Lineup

The Yamaha pro audio lineup includes everything you need to achieve professional sound in applications ranging from small events to large concerts. For serious power and system versatility, there is an excellent selection of independent components—mixers, amplifiers, equalizers, speakers. But when convenience and ease are the main criteria, there's a good range of powered mixers and speakers to choose from as well. Whatever your live sound needs, Yamaha has the solution.

Mixer

Mixing Console
MG102C
MG124C
MG166C
MG166C-USB
MG206C
MG206C-USB

P. 27

Mixing Console
MG82CX
MG124CX
MG166CX
MG166CX-USB

P. 27

Mixing Console
MG24/14FX
MG32/14FX

P. 28

Powered Mixer
EMX212S
EMX312SC
EMX512SC

P. 28

Powered Mixer
EMX5014C
EMX5016CF

P. 29

Mixing Console
IM8-24
IM8-32
IM8-40

P. 26

Digital Mixing Console
01V96VCM

P. 29

Signal Processor

Professional Multi-Effect Processor
SPX2000

P. 31

Graphic Equalizer
Q2031B

P. 31

Power Amp

Power Amplifier
P7000S
P5000S
P3500S
P2500S

P. 31

Speaker

Loud Speaker	Monitor Speaker	Sub Woofer
S112V	SM10V	SW115V
S115V	SM12V	SW118V
S215V	SM15V	SW218V
C112V	CM10V	CW115V
C115V	CM12V	CW118V
C215V	CM15V	CW218V
C112VA		
C115VA		

P. 32

Powered Speaker
MSR100
MSR250
MSR400
 Powered Sub Woofer
MSR800W

P. 34

Powered Speaker
MS101 III

P. 35

Loud Speaker
BR10
BR12
BR15

Monitor Speaker
BR12M
BR15M

P. 33

Recorder

Pocket Recorder
POCKETRAK C24
POCKETRAK W24

P. 35

Portable PA System
STAGEPAS 300

STAGEPAS 500

P. 36, 37

Portable PA System
STAGEPAS 150M
STAGEPAS 250M

P. 36, 37

Powered Monitor Speaker
HS50M
HS80M
 Powered Sub Woofer
HS10W

P. 38

Powered Monitor Speaker
MSP5 STUDIO
MSP7 STUDIO
 Powered Sub Woofer
SW10 STUDIO

P. 38

Tips 3

Selecting PA Equipment

The term "PA system" can be applied to an extremely wide range of equipment used to provide sound for an endless variety of applications. Here's a quick guide for selecting the right equipment for your application.

Mixer



How Many Microphone Inputs?

• Meetings, lectures, and other speech-based applications may only require a small mixer with a few microphone inputs. Live concerts, on the other hand, may involve microphones for vocals, chorus, and a multitude of musical instruments. The number of microphone inputs you need is the first requirement you should consider when choosing a mixer.

Reverb for Vocals

• If your application involves singing, you'll probably want to add some reverb and/or delay to the vocal sound. You could use external signal processing, but it might be more convenient to have this capability built right into the mixer. The EMX series powered mixers and MG series "CX" mixers feature a range of top-quality built-in effects.

Built-in Power

• Mixers with built-in power amplification are often simply referred to as "powered mixers." The benefits of this type of mixer include easier setup and greater portability (you don't have to carry and connect an external power amplifier). Powered mixers are recommended for applications such as meeting rooms or other situations in which the size of the room and audience remains constant.

Sound Processor (Graphic Equalizer)



Feedback Control

• Although you might think of graphic equalizers as precision sound-shaping tools (and they are), one of their main uses in live-sound applications is feedback control.

• Graphic equalizers divide the audio spectrum into narrow frequency bands that can be individually adjusted as required. The Yamaha Q2031B, for example, is a stereo graphic equalizer that provides 31 bands of adjustment per channel. Feedback can be prevented by reducing the level of the frequencies at which it is likely to occur.

• EMX-series mixers feature built-in graphic EQ.

Power Amp



One Watt Per Person

• The power output of a PA system is determined by the power amplifier(s) used. So how much power do you need? A basic rule of thumb is to allow about 1 watt per audience member. If your audience will be about 100 people, plan on having about 100 watts of power available.

• The one-watt-per-person rule is only a guideline, however, and the actual power requirements will be affected by many factors including the natural reverberation of the venue and the efficiency of the speakers used. Outdoor applications require considerably more power than indoor events. The type of music being performed will also affect the amount of power required. In all cases, it is a good idea to have some "extra" power to spare.

• Another important power-related issue to keep in mind is speaker protection. Speakers have a maximum power-handling capacity that, if exceeded, will result in speaker damage. Speakers with a greater power-handling capacity than the power output of the amplifiers used should always be chosen for safety.

* Professional sound engineers will generally use larger-than-necessary power amplifiers running at considerably lower than maximum output to maximize sound quality. In such cases great care must be taken not to exceed the speakers' maximum power-handling capacity.

Speakers



Speaker Efficiency

• Clearly the power output of a sound system is an important consideration, for which output "watts" is the most commonly used specification. But speaker efficiency also plays an important role in determining the "loudness" of the system.

• Yamaha specifies speaker efficiency by measuring sound pressure level one meter away from the cone of a speaker driven by one watt of power (dB SPL/1Wom). So for example, if 200 watts of power is supplied to the Yamaha SM10V speaker, which has an efficiency of 96 dB SPL/1Wom, the resultant sound pressure level will be 119 dB. But to achieve the same 119 dB sound pressure level with the SM15V, which has a higher efficiency of 99 dB SPL/1Wom, only 100 watts of power is required. An efficiency difference of only 3 dB means you have to either double or halve the amount of power provided to achieve the same sound pressure level (see below).

The Meaning of "dB"

If the smallest sound that can be heard by the human ear is given an arbitrary value of 1, then the loudest sound that can be heard is approximately 1,000,000 (one million) times louder. That's too many digits to deal with for practical calculations, and so the more appropriate "decibel" (dB) unit was created for sound-related measurements. In this system the difference between the softest and loudest sounds that can be heard is 120 dB. This is a non-linear scale, and a difference of 3 dB actually results in a doubling or halving of the loudness.

Ratio	0.01	0.1	0.5	1	2	4	5	8	10	100	1000
dB	-20dB	-10dB	-3dB	0dB	3dB	6dB	7dB	9dB	10dB	20dB	30dB

* The decibel scale is a relative scale based on an arbitrarily chosen "0" value. In most audio equipment 0 dB corresponds to a signal voltage of 0.775 V.

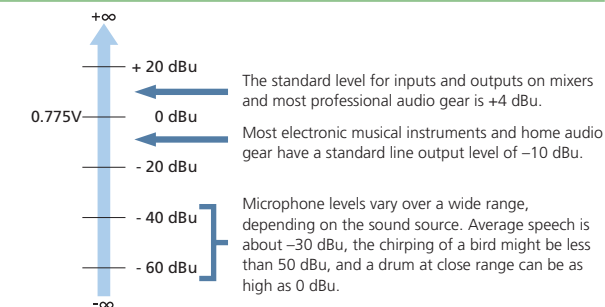

IM8 Series



MIXING CONSOLES

Solid Performance and Superior Sound for Professional Applications

The Yamaha IM8 series brings experience and know-how accumulated over 35 years in the production of industry-leading mixing consoles to bear in three mid-size consoles that cut no corners when it comes to overall performance and sonic quality. In addition to no-compromise design and development aimed at delivering the finest performance and most useful feature set available in this class, production and assembly are carried out at Yamaha's own domestic facilities – the same factories where the legendary Yamaha PM series consoles are produced – to ensure unrelenting quality control throughout. Every inch of these extraordinary consoles is well thought out and built for a purpose. There are no unnecessary features, and nothing is out of place. The IM8 series consoles deliver a basic but plentiful complement of features plus truly transparent, high-resolution sound with tireless reliability.

These are consoles for serious sound applications, and will provide eminently professional performance, sound, and control in permanent installations or on the road.



The IM8 Series

- IM8-40: 40 mono + 4 stereo inputs/8 aux + 8 group + 4 matrix + stereo + mono out buses
- IM8-32: 32 mono + 4 stereo inputs/8 aux + 8 group + 4 matrix + stereo + mono out buses
- IM8-24: 24 mono + 4 stereo inputs/8 aux + 8 group + 4 matrix + stereo + mono out buses

Main Features

- Professional build, features, and performance for serious live sound applications.
- Domestic production and assembly ensure faultless quality control.
- Unique Yamaha one-knob compressor on all mono input channels.
- Comprehensive master section provides extensive signal routing and control versatility.
- Output matrix affords extra output flexibility, particularly for installations.
- Traditional Yamaha color coded controls for easy identification and operation.
- USB audio I/O allows direct digital recording and playback with the supplied Cubase AI4 audio workstation software.
- External power supply maximizes console performance – dual power supplies can be used for redundant failsafe operation.

Options

PW8
POWER SUPPLY



PSL1010
POWER SUPPLY LINK CABLE

LA1L
GOOSENECK LAMP



Specifications

	IM8-24	IM8-32	IM8-40
Total Harmonic Distortion		Less than 0.1% (20Hz to 20kHz)	
Frequency Response	0, +1, -3dB (20Hz to 20kHz)		
Input Hum & Noise *1	Equivalent input noise; -128dBu, Residual noise; -98dBu		
Crosstalk	Less than -70dB		
Phantom Power	+48V DC (each channel)		
CH & ST High Pass Filter	80Hz, 12dB/oct		
Input	MIC: 24, LINE: 24 mono + 4 stereo, CH INSERT: 24, GROUP INSERT: 8, AUX INSERT: 8, ST INSERT: 1, MONO INSERT: 1, AUX RETURN: 4 stereo, 2TR: 1 stereo, TB IN: 1	MIC: 32, LINE: 32 mono + 4 stereo, CH INSERT: 32, GROUP INSERT: 8, AUX INSERT: 8, ST INSERT: 1, MONO INSERT: 1, AUX RETURN: 4 stereo, 2TR: 1 stereo, TB IN: 1	MIC: 40, LINE: 40 mono + 4 stereo, CH INSERT: 40, GROUP INSERT: 8, AUX INSERT: 8, ST INSERT: 1, MONO INSERT: 1, AUX RETURN: 4 stereo, 2TR: 1 stereo, TB IN: 1
Output	STEREO OUT: 1, GROUP: 8, AUX SEND: 8, MONO: 1, MATRIX OUT: 4, CH INSERT: 24, AUX INSERT: 8, GROUP INSERT: 8, ST INSERT: 1, MONO INSERT: 1, DIRECT: 24, REC: 1 stereo, MONITOR: 1 stereo, PHONES: 1	STEREO OUT: 1, GROUP: 8, AUX SEND: 8, MONO: 1, MATRIX OUT: 4, CH INSERT: 32, AUX INSERT: 8, GROUP INSERT: 8, ST INSERT: 1, MONO INSERT: 1, DIRECT: 32, REC: 1 stereo, MONITOR: 1 stereo, PHONES: 1	STEREO OUT: 1, GROUP: 8, AUX SEND: 8, MONO: 1, MATRIX OUT: 4, CH INSERT: 40, AUX INSERT: 8, GROUP INSERT: 8, ST INSERT: 1, MONO INSERT: 1, DIRECT: 40, REC: 1 stereo, MONITOR: 1 stereo, PHONES: 1
Compressor	24 (Mic channel Only)		
CH EQ (MONO) *2 ±15 dB (Max.)	32 (Mic channel Only) HIGH: 10 kHz (shelving) HI-MID: 400 Hz-8 kHz (peaking) LO-MID: 80 Hz-1.6 kHz (peaking) LOW: 100 Hz (shelving)		
CH EQ (STEREO) *2 ±15 dB (Max.)	40 (Mic channel Only) HIGH: 10 kHz (shelving) HI-MID: 3 kHz (peaking) LO-MID: 800 Hz (peaking) LOW: 100 Hz (shelving)		
Internal Digital Effect	-		
USB Audio USB IN/OUT	YES		
Dimensions (W x H x D mm)	1227 x 219 x 739	1471.5 x 219 x 739	1716 x 219 x 739
Weight	37.5 kg	44.5 kg	51.5 kg
Power Requirements	Use PW8 power supply unit		
Option	Power supply unit PW8, Power supply link cable PSL1010, Gooseneck lamp LA1L		

MG Series

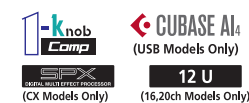

MIXING CONSOLES

An Impressive Lineup with a Common Theme—Unmatched Quality and Performance

Whether you have a mixing application that involves only a few channels, or up to 32 inputs with substantial signal routing versatility, Yamaha's MG series offers a console that will give you the capacity, control, and performance you deserve. All models are remarkably compact and lightweight for superior handling and portability, but absolutely no compromises have been made in terms of features, performance, or durability. The MG mixers offer an extraordinary blend of technology: some inherited from professional Yamaha mixing consoles you're likely to see in distinguished halls throughout the world, and some developed specifically to deliver optimum performance in the MG-console format. In either case these performance packed mixers are founded on a world-spanning network of human and technological resources that crystallize to deliver features that really matter, and sound that is undeniably superior.



C Models with Improved Utility

10, 12, 16, and 20 channel models for a wide range of applications. They may be the most basic models in the series, but they're packed with features and performance that will let you create superior mixes with ease.

CX Models with SPX Digital Effects

With outstanding Yamaha SPX multi-effects built in, these models offer an extraordinary range of creative control while eliminating the need for bulky external effect racks.

USB Models for Live Recording

If live recording is an important aspect of your application, choose one of the USB models. They allow top-quality 2-track digital recording with the bundled CUBASE AI4 digital audio workstation software.

Specifications

	MG102C	MG124C	MG166C	MG206C	MGB2CX
Total Harmonic Distortion	0.1 % (THD+N) +14 dBu, 20Hz – 20kHz, Input Gain Control at minimum (ST OUT)				
Frequency Response	-3, 0, +1dB 20Hz – 20kHz @ +4dBu (ST OUT)				
Input Hum & Noise *1	-128dBu Equivalent Input Noise/ -98dBu Residual Output Noise, 20Hz – 20kHz, Rs=150Ω, Input Gain=Maximum, Input sensitivity=-60dB	-128dBu Equivalent Input Noise/ -98dBu Residual Output Noise, 20Hz – 20kHz, Rs=150Ω, Input Gain=Maximum, Input sensitivity=-60 dB	-128dBu Equivalent Input Noise/ -98dBu Residual Output Noise, 20Hz – 20kHz, Rs=150Ω, Input Gain=Maximum, Input sensitivity=-60 dB	-128dBu Equivalent Input Noise/ -98dBu Residual Output Noise, 20Hz – 20kHz, Rs=150Ω, Input Gain=Maximum, Input sensitivity=-60 dB	-128dBu Equivalent Input Noise/ -98dBu Residual Output Noise, 20Hz – 20kHz, Rs=150Ω, Input Gain=Maximum, Input sensitivity=-60dB
Crosstalk	-70dB @ 1kHz				
Phantom Power	+ 48V				
CH & ST High Pass Filter	80Hz 12dB/Octave				
Input	MIC: 4, LINE: 2 mono + 4 stereo, CH INSERT: 2, RETURN: 1 stereo, 2TR IN: 1 stereo	MIC: 6, LINE: 4 mono + 4 stereo, CH INSERT: 4, RETURN: 1 stereo, 2TR IN: 1 stereo	MIC: 10, LINE: 8 mono + 4 stereo, CH INSERT: 8, RETURN: 1 stereo, 2TR IN: 1 stereo	MIC: 16, LINE: 12 mono + 4 stereo, CH INSERT: 12, RETURN: 2 stereo, 2TR IN: 1 stereo	MIC: 4, LINE: 2 mono + 4 stereo, CH INSERT: 2, RETURN: 1 stereo, 2TR IN: 1 stereo
Output	ST: 1, AUX SEND: 1, CH INSERT: 2, REC: 1 stereo, MONITOR: 1 stereo, PHONE: 1	ST: 2, AUX SEND: 2, CH INSERT: 4, REC: 1 stereo, MONITOR: 1 stereo, GROUP: 2, Phone: 1	ST: 2, AUX SEND: 3, CH INSERT: 8, REC: 1 stereo, MONITOR: 1 stereo, GROUP: 4, Phone: 1	ST: 2, AUX SEND: 4, CH INSERT: 12, REC: 1 stereo, MONITOR: 1 stereo, GROUP: 4, Phone: 1	ST: 1, EFFECT SEND: 1, CH INSERT: 2, REC: 1 stereo, MONITOR: 1 stereo, PHONE: 1
CH EQ (MONO) *2 ±15 dB (Max.)	10 k Hz (Shelving), 2.5 kHz (Peaking), 100 Hz (Shelving)	10 k Hz (Shelving), 2.5 kHz (Peaking), 100 Hz (Shelving)	10 k Hz (Shelving), 2.5 kHz (Peaking), 100 Hz (Shelving)	10 k Hz (Shelving), 2.5 kHz (Peaking), 100 Hz (Shelving)	10 k Hz (Shelving), 2.5 kHz (Peaking), 100 Hz (Shelving)
CH EQ (STEREO) *2 ±15 dB (Max.)	10 k Hz (Shelving), 100 Hz (Shelving)	10 k Hz (Shelving), 100 Hz (Shelving)	10 k Hz (Shelving), 2.5 kHz (Peaking), 100 Hz (Shelving)	10 k Hz (Shelving), 2.5 kHz (Peaking), 100 Hz (Shelving)	10 k Hz (Shelving), 100 Hz (Shelving)
Internal Digital Effect	-				16 Programs: Parameter Control Foot Switch (Digital Effect On/Off)
USB Audio USB IN/OUT	-				
Dimensions (W x H x D mm)	256.6 x 62.2 x 302.5	346.2 x 86.1 x 436.6	478 x 105 x 496	478 x 105 x 496	256.6 x 62.2 x 302.5
Weight	1.5 kg	3.0 kg	5.3 kg	6.0 kg	1.6 kg
Power Requirements	21W	30W	30W	40W	21W
Option	BMS-10A (Mic Stand Adaptor)	-	-	-	BMS-10A (Mic Stand Adaptor), FCS (Foot SW)

	MG124CX	MG166CX	MG166C-USB	MG166CX-USB	MG206C-USB
Total Harmonic Distortion	0.1 % (THD+N) +14 dBu, 20Hz – 20kHz, Input Gain Control at minimum (ST OUT)				
Frequency Response	-3, 0, +1dB 20Hz – 20kHz @ +4dBu (ST OUT)				
Input Hum & Noise *1	-128dBu Equivalent Input Noise/ -98dBu Residual Output Noise, 20Hz – 20kHz, Rs=150Ω, Input Gain=Maximum, Input sensitivity=-60 dB	-128dBu Equivalent Input Noise/ -98dBu Residual Output Noise, 20Hz – 20kHz, Rs=150Ω, Input Gain=Maximum, Input sensitivity=-60 dB	-128dBu Equivalent Input Noise/ -98dBu Residual Output Noise, 20Hz – 20kHz, Rs=150Ω, Input Gain=Maximum, Input sensitivity=-60 dB	-128dBu Equivalent Input Noise/ -98dBu Residual Output Noise, 20Hz – 20kHz, Rs=150Ω, Input Gain=Maximum, Input sensitivity=-60 dB	-128dBu Equivalent Input Noise/ -98dBu Residual Output Noise, 20Hz – 20kHz, Rs=150Ω, Input Gain=Maximum, Input sensitivity=-60 dB
Crosstalk	-70dB @ 1kHz				
Phantom Power	+ 48V				
CH & ST High Pass Filter	80Hz 12dB/Octave				
Input	MIC: 6, LINE: 4 mono + 4 stereo, CH INSERT: 4, RETURN: 1 stereo, 2TR IN: 1 stereo	MIC: 10, LINE: 8 mono + 4 stereo, CH INSERT: 8, RETURN: 1 stereo, 2TR IN: 1 stereo	MIC: 10, LINE: 8 mono + 4 stereo, CH INSERT: 8, RETURN: 1 stereo, 2TR IN: 1 stereo	MIC: 10, LINE: 8 mono + 4 stereo, CH INSERT: 8, RETURN: 1 stereo, 2TR IN: 1 stereo	MIC: 16, LINE: 12 mono + 4 stereo, CH INSERT: 12, RETURN: 2 stereo, 2TR IN: 1 stereo
Output	ST: 2, AUX SEND: 1, EFFECT SEND: 1, CH INSERT: 4, REC: 1 stereo, MONITOR: 1 stereo, GROUP: 2, Phone: 1	ST: 2, AUX SEND: 2, EFFECT SEND: 1, CH INSERT: 8, REC: 1 stereo, MONITOR: 1 stereo, GROUP: 4, Phone: 1	ST: 2, AUX SEND: 3, CH INSERT: 8, REC: 1 stereo, MONITOR: 1 stereo, GROUP: 4, Phone: 1	ST: 2, AUX SEND: 2, EFFECT SEND: 1, CH INSERT: 8, REC: 1 stereo, MONITOR: 1 stereo, GROUP: 4, Phone: 1	ST: 2, AUX SEND: 4, CH INSERT: 12, REC: 1 stereo, MONITOR: 1 stereo, GROUP: 4, Phone: 1
CH EQ (MONO) *2 ±15 dB (Max.)	10 k Hz (Shelving), 2.5 kHz (Peaking), 100 Hz (Shelving)	10 k Hz (Shelving), 2.5 kHz (Peaking), 100 Hz (Shelving)	10 k Hz (Shelving), 2.5 kHz (Peaking), 100 Hz (Shelving)	10 k Hz (Shelving), 2.5 kHz (Peaking), 100 Hz (Shelving)	10 k Hz (Shelving), 2.5 kHz (Peaking), 100 Hz (Shelving)
CH EQ (STEREO) *2 ±15 dB (Max.)	10 k Hz (Shelving), 100 Hz (Shelving)	10 k Hz (Shelving), 2.5 kHz (Peaking), 100 Hz (Shelving)	10 k Hz (Shelving), 2.5 kHz (Peaking), 100 Hz (Shelving)	10 k Hz (Shelving), 2.5 kHz (Peaking), 100 Hz (Shelving)	10 k Hz (Shelving), 2.5 kHz (Peaking), 100 Hz (Shelving)
Internal Digital Effect	16 Programs: Parameter Control Foot Switch (Digital Effect On/Off)	16 Programs: Parameter Control Foot Switch (Digital Effect On/Off)	-	16 Programs: Parameter Control Foot Switch (Digital Effect On/Off)	-
USB Audio USB IN/OUT	-		Sampling Frequency = 44.1kHz or 48kHz (depend on the application of PC)	Sampling Frequency = 44.1kHz or 48kHz (depend on the application of PC)	Sampling Frequency = 44.1kHz or 48kHz (depend on the application of PC)
Dimensions (W x H x D mm)	346.2 x 86.1 x 436.6	478 x 105 x 496	478 x 105 x 496	478 x 105 x 496	478 x 105 x 496
Weight	3.2 kg	5.5 kg	5.3 kg	5.5 kg	6.0 kg
Power Requirements	30W	35W	30W	35W	40W
Option	FCS (Foot SW)	FCS (Foot SW)	-	FCS (Foot SW)	-

*1 Hum & Noise are measured with a 6dB/octave filter @ 12.7kHz, equivalent to a 20kHz filter with infinite dB/octave attenuation.

*2 Turn over /roll-off frequency of shelving : 3dB below maximum variable level.



P.T. Yamaha Music manufacturing Asia

—Manufacturing the electronic instruments and PA products

From the initial design to final manufacturing, all production processes for the Yamaha EMX series Powered Mixers and MG series Mixing Consoles are performed entirely inside the company.

Moreover, every product that comes off our production line must pass strict quality controls using the sophisticated test instruments. Thus, all of this enables us to deliver the highest quality products to you.

An Interview with the EMX/MG Design Team

Built-in Compression Adds Live-sound Versatility to the new EMX-series Powered Mixers

New Features

* What is the main difference compared to previous EMX-series mixers?

The main difference is built-in compression. Compression is indispensable in almost all professional recording and live-sound applications, but we believe that this is the first time it has been built into an analog live mixer.

Most "box type" mixers have no insert connectors, so there has really been no convenient way to use compression with them. As a result, many users of this type of powered mixer have never used compression, but we wanted them to have that option in the new EMX series.

Although compression is used in most pro audio applications, it has been a bit too difficult for beginners to take full advantage of. That's why we've streamlined it down to the essentials and made it very easy to use.

Another important new feature is FCL (Feedback Channel Location). This system detects feedback and shows you which channel is causing the problem. Some mixers from other manufacturers have indicators in the graphic equalizer section that show the feedback frequency, but indicating the problem channel allows the feedback to be more effectively controlled using channel EQ.

If you try to control feedback using the EMX graphic equalizer, for example, you end up changing the sound of the entire program. For this reason it is far more effective to control it at the input, thus avoiding degradation of the overall sound.

The Battle Against Heat

* Tell us about how you avoided heat problems in such compact enclosures.

Heat and high power output unavoidably go hand-in-hand. In this case we were also determined to reduce weight, so the design, hardware, and mechanics teams joined forces to pursue this goal. Changing even a single component can alter the heat profile enough to require a change in heat sink design, and that change can cause a change in sound quality, so the design process involves a lot of trial and error.

In this particular case, the fact that we were able to use internal heat-flow simulation and analysis was a huge advantage. We were able to define an enclosure shape on the computer, and then by analyzing the heat flow while refining the heat sink configuration we were able to come to within 80% or 90% of the ideal final design. The final stages using physical prototypes still relied on trial and error.

In the box-type 212C, 312SC, and 512SC, it was easy to mount the fan away from the circuit board to minimize degradation of the audio signal. But in the console-type EMX5016CF and EMX5014C finding the ideal fan location was extremely difficult. Since the fan must be located near the input circuitry, special measures have been taken to ensure that electronic and mechanical noise from the fan do not affect sound quality, while at the same time ensuring maximum heat extraction.

The hardware team wanted to increase the size of the body by 30 millimeters, but our goals for a streamlined, compact design were important enough that we decided to find other ways to achieve the desired performance.

Reliability Without Compromising Performance

* The simplicity and aesthetic appeal of the designs are quite impressive. Tell us about the design concept.

Simplicity was the main goal, particularly in the console-type 5016CF and 5014C. We wanted to consolidate the mixer controls, so the utility control section has been clearly separated. We didn't even want any handles to be visible.

An important idea implemented in the box-type models is that they can be set at an angle like monitor speakers. The integral handles are also an important design feature, and achieving the required strength was a constant problem.

Achieving the ideal blend of size, weight, and durability is quite difficult. As usual, demands from the sales team continue to escalate while the hardware and mechanics teams try to turn them into reality... without ever reducing or compromising features or performance. Computer simulation was called into play once again, providing an accurate preview of the mold-flow characteristics of the resin used for the box-type housings.

The final strength of the molded housings depends to a large degree on how the molten resin is introduced in the mold, and how it flows within the mold.

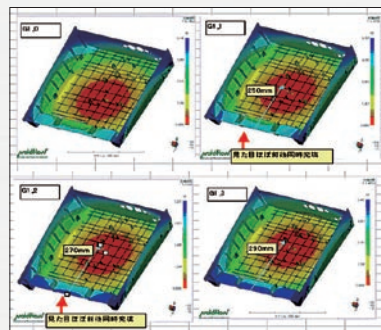

The strength of the integral handles was also predicted using computer simulation, and as a result we have achieved strength comparable to that of aluminum.

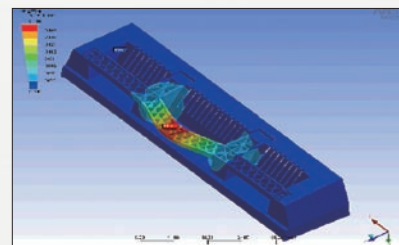

Achieving Pure Sound Quality

* What measures have been taken to ensure optimum sound quality?

Of course sound quality is first and foremost in the design of any model. Achieving the lowest possible noise and hum when changing components is always a challenge. There's influence from vibration, from the current flowing through the components themselves, and a simple op-amp IC change can precipitate a large change in sound. We often find ourselves using the best components we can find rather than compromise on sound quality. Even the FCL system has an effect on the sound, and we were able to achieve a dramatic improvement by simply eliminating a single component from the circuit. Once again, the final design depends on trial-and-error listening tests while changing components.

With SPX effects in all models in this EMX series, plus compression and FCL, you can rely on a single EMX powered mixer to deliver outstanding live sound, especially in applications that use mostly microphones.

* Most compressors have at least two controls, what is the idea behind having just one?

Simplicity. Standard compression controls can be very difficult to set quickly and accurately, but we've managed to provide well-balanced threshold and ratio settings that can be controlled by a single knob. By focusing primarily on microphone applications in which compression is applied to vocals, acoustic guitar, or similar sources, great-sounding compression can be dialed in quickly and easily.

There's a good description of compression and its uses in the owner's manual. We hope that our users will take advantage of this very useful feature.

SPX2000

PROFESSIONAL MULTI-EFFECT PROCESSOR

The SPX2000, while inheriting the standard interface and common programs from its predecessors, brings a new sound quality with the "REV-X" reverb algorithm and the 24 bit/96-kHz audio DSP.



• 24-bit Linear 128-times/64-times Oversampling (@fs=44.1, 48kHz/88.2, 96kHz) • PRESET BANK: 97, USER BANK: 99, CLASSIC BANK: 25 • AC 120V, 60Hz, AC 230V, 50Hz, 25W • 480W x 45H x 372.5D mm, 4kg

SPX History

The good reputation from users keeps our SPX effects as standard effects over 15 years...

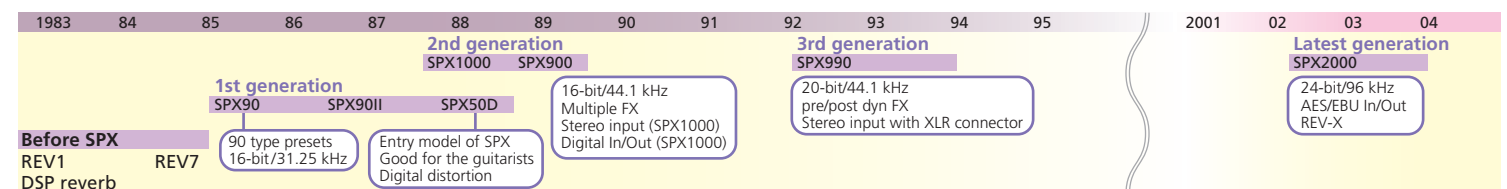

Q2031B

GRAPHIC EQUALIZER

Yamaha Graphic Equalizers offer features and performance that meet today's equalization needs whether they be in sound reinforcement, recording, A/V production, electronic musical instruments, broadcasting, music listening, or any other applications where precise sound tailoring is essential.



• 31 band (1/3 octave) • Variable Range: +/- 12dB, +/- 6dB I HPF: 12dB/octave (20 - 200Hz at -3dB point.) • AC 120V, 60Hz, AC 230V, 50Hz • 20W • 480 x 93.4 x 230mm, 4.0kg

P-Series

POWER AMPLIFIERS

The P-Series power amplifiers have been designed specifically to deliver big, clean power output that will take full advantage of the quality and power handling capabilities of Yamaha speakers. The amps are equipped with YS Processing (Yamaha Speaker Processing) to deliver a signal that is optimally matched to those speakers as well. All models feature both XLR and 1/4-inch TRS inputs, and Neutrik Speakon, phone plug, and five-way binding post outputs to make connections quick and easy. Other features include Yamaha's exclusive EEEngine technology which delivers high performance with exceptional efficiency, sweepable high- and low- pass filters for optimizing output to any loudspeakers, compact and durable 2U chassis, and variable speed cooling fans.

P7000S



P5000S



P3500S



P2500S



Sound Advice

So what does this YSP (Yamaha Speaker Processing) switch do, anyway? Glad you asked: it rolls off unnecessary frequencies below around 40 Hz, which helps to protect your speakers, and at the same time boosts frequencies from 60 Hz through 150 Hz by about 3 or 4 dB which, as you rocket scientists already know, is a sound-pressure-level boost of about 1.5 times. And although this won't give you the bone-shaking bass of a subwoofer, it will make your bass and drums sound really cool. If you're reinforcing rock, turn it on.

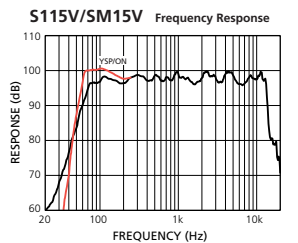

Specifications

	P7000S	P5000S	P3500S	P2500S
Output Power	8 ohms/STEREO	750W+750W	525W+525W	390W+390W
	20Hz - 20kHz	1100W+1100W	750W+750W	590W+590W
	4 ohms/STEREO	2000W	1500W	1180W
THD+N	20Hz - 20kHz, half power	≤ 0.10%		
Intermodulation Distortion	60Hz: 7kHz, 4:1, half power	≤ 0.10%		
Frequency Response	Po=1W, RL=8 ohms	0dB, +0.5dB, -1dB f=20Hz - 50kHz		
Channel Separation	half power	≥ 70dB 1kHz		
Residual noise Att. min	Att.max	≥ 70dB		
	DIN AUDIO	104dB	103dB	102dB
S/N ratio	DIN AUDIO	32.1dB		
Voltage Gain	Att.max	32.1dB		
Input Impedance	DIN AUDIO	30kΩ (balance) 15kΩ (unbalance)		
Connectors	Input	XLR-3-31 type/ch, 1/4" TRS/ch		
	Output	SPEAKON, 5way binding post, 1/4" phone/ch		
Limiter Circuit		comp. THD ≥ 0.5%		
Cooling		Dual variable-speed fan		Single variable-speed fan
Power Requirements		20V 60Hz, 230V 50Hz, 240V 50Hz		
Idle Power Consumption		35W	35W	30W
Maximum Power Consumption (4 ohms)		4000W	3000W	2000W
Dimensions (W x H x D): mm		480 x 88 x 456		
Weight		12kg	12kg	15kg

• 0dB=0.775V • half power=1/2 output power
* Output power into 8Ω stereo (20Hz - 20kHz) on the P7000S 230V model is 650W + 650W.

Club V Loudspeakers S-Series & C-Series



Great Sound To Go

If you're tired of breaking your back for mediocre speaker performance, it's time to look at the Yamaha Club V S-Series. Although they easily load into and out of your compact sedan, they also deliver power and performance that makes them ideal for up to mid-sized sound reinforcement systems. And in the world of the touring PA, there's virtually no way you can cart gear around without bumping into the occasional immovable object, so you'll appreciate the durable carpet covering – which also protects the interior of your vehicle from the speakers. Heavy-gauge steel grilles and steel protectors help protect your investment, too. In the Club V S-Series the refinements of generation V are taken to the next level, with larger enclosures for improved low-frequency performance, improved drivers for higher power handling, re-designed crossovers, stronger grilles, and dual Speakon® and 1/4" connectors.

Superior Sound on the Ground or Overhead



The Club V C-Series includes two "VA" flyable models that are ideal for installations. In fact, the entire series features foam-backed full-face perforated steel grilles and a sprayed finish that makes for elegant yet unobtrusive installations. Performance-wise, the C-Series speakers offer the same specs as the S-Series, with large enclosures for improved low-frequency performance, improved drivers for higher power handling, re-designed crossovers, stronger grilles, and dual Speakon® and 1/4" connectors.

Specifications

*S-series are carpet finish, C-series are sprayed finish.

Club V S- & C- series

	S112V, C112V	S115V, C115V	S215V, C215V	SM10V, CM10V	SM12V, CM12V	SM15V, CM15V
Type	12" 2 way bass reflex	15" 2 way bass reflex	15" x 2.2 way bass reflex	10" 2 way bass reflex	12" 2 way bass reflex	15" 2 way bass reflex
Frequency Range	60Hz – 16kHz (-10dB)	55Hz – 16kHz (-10dB)	42Hz – 16kHz (-10dB)	70Hz – 20kHz (-10dB)	60Hz – 16kHz (-10dB)	55Hz – 16kHz (-10dB)
Power Capacity	175 watts (NOISE)* 350 watts (PGM) 700 watts (MAX)	250 watts (NOISE)* 500 watts (PGM) 1000 watts (MAX)	500 watts (NOISE)* 1000 watts (PGM) 2000 watts (MAX)	125 watts (NOISE)* 250 watts (PGM) 500 watts (MAX)	175 watts (NOISE)* 350 watts (PGM) 700 watts (MAX)	250 watts (NOISE)* 500 watts (PGM) 1000 watts (MAX)
Nominal Impedance	8 ohms	8 ohms	4 ohms	8 ohms	8 ohms	8 ohms
Sensitivity	97dB	99dB	99dB	96dB	97dB	99dB
LF Driver	12" cone	15" cone	15" cone x 2	10" cone	12" cone	15" cone
HF Driver	2" vc, Titanium Horn	2" vc, Titanium Horn	2" vc, Titanium Horn	1" vc, Titanium Horn	2" vc, Titanium Horn	2" vc, Titanium Horn
Crossover Frequency	2kHz	1.7kHz	1.5kHz	1.8kHz	2kHz	1.7kHz
Finish	S: Carpet, C: Sprayed	S: Carpet, C: Sprayed	S: Carpet, C: Sprayed	S: Carpet, C: Sprayed	S: Carpet, C: Sprayed	S: Carpet, C: Sprayed
Input Connectors	1/4" Phone x 2, Speakon x 2	1/4" Phone x 2, Speakon x 2	1/4" Phone x 2, Speakon x 2	1/4" Phone x 2, Speakon x 2	1/4" Phone x 2, Speakon x 2	1/4" Phone x 2, Speakon x 2
Dimensions (W x H x D mm)	S: 420 x 632 x 333 C: 416 x 628 x 329	S: 489 x 719 x 377 C: 485 x 715 x 373	S: 495 x 1167 x 597 C: 491 x 1163 x 593	S: 560 x 353 x 277 C: 556 x 349 x 273	S: 632 x 414 x 351 C: 628 x 410 x 339	S: 719 x 483 x 343 C: 715 x 479 x 339
Net Weight	S: 20.8 kg, C: 21.3 kg	S: 29.4 kg, C: 30.3 kg	S: 47.2 kg, C: 47.5 kg	S: 13.4 kg, C: 13.3 kg	S: 21.4 kg, C: 21.8 kg	S: 28.0 kg, C: 28.8 kg

Club V S- & C- series

	SW115V, CW115V	SW118V, CW118V	SW218V, CW218V	C112VA	C115VA
Type	15" Bass reflex	18" bass reflex	18" x 2 Bass reflex	12" 2 way bass reflex	15" bass reflex
Frequency Range	35Hz – 2kHz (-10dB)	30Hz – 2kHz (-10dB)	30Hz – 2kHz (-10dB)	60Hz – 16kHz (-10dB)	55Hz – 16kHz (-10dB)
Power Capacity	250 watts (NOISE)* 500 watts (PGM) 1000 watts (MAX)	300 watts (NOISE)* 600 watts (PGM) 1200 watts (MAX)	600 watts (NOISE)* 1200 watts (PGM) 2400 watts (MAX)	175 watts (NOISE)* 350 watts (PGM) 700 watts (MAX)	250 watts (NOISE)* 500 watts (PGM) 1000 watts (MAX)
Nominal Impedance	8 ohms	8 ohms	4 ohms	8 ohms	8 ohms
Sensitivity	95dB	96dB	98dB	97dB	99dB
LF Driver	15" cone	18" cone	18" cone x 2	12" cone	15" cone
HF Driver	–	–	–	2" vc, Titanium Horn	2" vc, Titanium Horn
Crossover Frequency	90Hz, 12dB/Oct.	90Hz, 12dB/Oct.	90Hz, 12dB/Oct.	2kHz	1.7kHz
Finish	S: Carpet, C: Sprayed	S: Carpet, C: Sprayed	S: Carpet, C: Sprayed	Sprayed	Sprayed
Input Connectors	1/4" Phone x 2, Speakon x2	1/4" Phone x 2, Speakon x2	1/4" Phone x 2, Speakon x2	Barrier strip	Barrier strip
Dimensions (W x H x D mm)	S: 506 x 611 x 532 C: 500 x 607 x 528	S: 610 x 728 x 641 C: 605 x 720 x 637	S: 1221 x 578 x 659 C: 1217 x 574 x 655	416 x 620 x 329	485 x 715 x 373
Net Weight	S: 28.2 kg, C: 28.0 kg	S: 39.0 kg, C: 37.2 kg	S: 65.4 kg, C: 64.7 kg	21.8 kg	29.9 kg

BR-Series Speakers



Great Sound and Easy handling

Whether you're playing to a rock'n roll, jazz, or classic crowd, or delivering an important spoken message, Yamaha BR-Series speakers will ensure that you're heard clearly. With the right powered mixer, or standard mixer and power amplifiers, these units can pack a heck of a wallop... make that a "high-quality wallop." But when the show is done and it's time to tear down the system and go home, you'll appreciate these speakers a second time—they're compact, remarkably light for their power and performance, and are designed for easy handling. All models, even the monitors, offer integral pole sockets for easy stand mounting.

Specifications

BR-Series

	BR10	BR12	BR15	BR12M	BR15M
Type	10" 2 way bass reflex	12" 2 way bass reflex	15" 2 way bass reflex	12" 2 way bass reflex	15" 2 way bass reflex
Frequency Range	65Hz – 20kHz (-10dB)	60Hz – 20kHz (-10dB)	60Hz – 20kHz (-10dB)	60Hz – 20kHz (-10dB)	60Hz – 20kHz (-10dB)
Power Capacity	125 watts (NOISE)* 250 watts (PGM) 500 watts (MAX)	150 watts (NOISE)* 300 watts (PGM) 600 watts (MAX)	200 watts (NOISE)* 400 watts (PGM) 800 watts (MAX)	150 watts (NOISE)* 300 watts (PGM) 600 watts (MAX)	200 watts (NOISE)* 400 watts (PGM) 800 watts (MAX)
Nominal Impedance	8 ohms	8 ohms	8 ohms	8 ohms	8 ohms
Sensitivity	96dB	97dB	98dB	97dB	98dB
LF Driver	10" cone	12" cone	15" cone	12" cone	15" cone
HF Driver	1" vc, Titanium Horn	1" vc, Titanium Horn	1" vc, Titanium Horn	1" vc, Titanium Horn	1" vc, Titanium Horn
Finish	Carpet	Carpet	Carpet	Carpet	Carpet
Input Connectors	1/4" Phone x 2	1/4" Phone x 2	1/4" Phone x 2	1/4" Phone x 2	1/4" Phone x 2
Dimensions (W x H x D mm)	375 x 537 x 326	403 x 569 x 335	485 x 656 x 365	569 x 407 x 334	652 x 487 x 365
Net Weight	14.4 kg	16 kg	21.3 kg	15.6 kg	20.9 kg

*EIA RS426A

4 Simple Steps To Better Sound

Why use monitor speakers?

While the purpose of the main or "FOH" (Front Of House) speakers is to deliver the sound to the audience, monitor speakers are necessary to provide a sound reference to the speakers or musicians performing on stage. This was sometimes also known as "foldback". A monitor system allows performers to clearly hear what they are saying, singing, or playing so that they can perform with confidence and provide performances of the highest quality. It may not be an exaggeration to say that a good monitor system is the key to a successful concert or event.



SM12V

BR12M

MSR Series Speakers

POWERED SPEAKERS



MSR400 / 800W



MSR250

Powered speakers offer many advantages over their passive counterparts, whether used on the road or in permanent installations. You don't need separate amplifiers or the extra cables and connections required, so setup is fast and easy while reliability is significantly improved. The ability to plug directly into the speaker inputs can eliminate an entire rack of amplifiers in a modest-size system. But the benefits go beyond mere convenience. Optimum matching of amplifiers and speakers involves much more than simple impedance figures, and can be a formidable engineering task given the vast number of choices available. The Yamaha MSR-series power amplifiers have been ideally mated to their respective speakers in every way possible, delivering reproduction quality that only the most stringent matching can achieve. There are also a significant number of Yamaha refinements that put these extraordinary powered speakers in a class of their own, including an original cabinet design that eliminates internal standing waves*1 and ferrofluid-cooled voice coils for superior stability and linearity*2.

The MSR250, MSR400 or MSR100 powered speakers can be used alone or in combination with the MSR800W powered subwoofer to create sound reinforcement systems from modest to massive that will sound superb while delivering the power and coverage you need for success in just about any venue or at any event. They look great too, and can be used as-is in many permanent installations without requiring any cosmetic cover-up. They're more than rugged enough for demanding tour applications as well.

*1 MSR250 and MSR400 *2 MSR100 and MSR250

Portable, Compact Solutions for Superior Sound and Convenience



Specifications

	MSR100	MSR250	MSR400	MSR800W
Type	2-way Powered Speaker	2-way Powered Speaker	Biamp. 2-way Powered Speaker	Powered Subwoofer
Frequency Range	55Hz – 20 kHz (-10 dB)	55Hz – 20kHz (-10dB)	50Hz – 20kHz (-10dB)	40Hz – 120Hz
Maximum Output Level (SPL)	112dB (1 m on Axis)	116dB (1m, on axis)	121dB (1m)	122dB (1m)
LF Driver	8" Cone	10" Cone	12" Cone	15" Cone
HF Driver	1" V.C. Compression Driver	1" V.C. Compression Driver	1.75" V.C. Compression Driver	—
Maximum Output Power	100 W at 1 kHz, THD=1 %, RL=6 Ω	200 W at 1 kHz, THD=1 %, RL=4 Ω	Bi-amplified system LF: 225 W/4 Ω HF: 75 W/16 Ω Maximum Power: 400 W Total	500 W at 100 Hz, THD=1 %, RL=8 Ω Maximum Power: 800 W
Input sensitivity	INPUT 1: -50 dB (Mic)/+4 dB (Line), 10 kΩ (Line), (with select SW) INPUT 2 & 3: -10 dB, 10 kΩ (Line)	INPUT 1 (XLR): -60 dBu (Mic)/-30 dBu (Line), (PHONE): -50 dBu (Mic)/-20 dBu (Line), INPUT 2/3: -20 dBu	Mic/Line: -36 dB/+4 dB, 10 kΩ	+4dB/30 kΩ
Controls	Level Control INPUT 1, 2 & 3, Master Level, EQ, LOW: ± 3 dB at 60 Hz, HIGH: ± 6 dB at 10 kHz, POWER Switch (ON/OFF)	LEVEL CONTROL: INPUT 1, 2/3, EQ, LOW: ± 3 dB at 60 Hz, HIGH: ± 6 dB at 10 kHz, POWER Switch (ON/OFF)	LEVEL CONTROL, EQ, LOW: ± 3 dB at 55 Hz, HIGH: ± 3 dB at 1.6 kHz, POWER Switch (ON/OFF)	MASTER LEVEL CONTROL, CUTOFF FREQ. Control: 80 – 100 Hz (Variable), PHASE Switch: (NORM/REV), POWER Switch: ON/OFF
Connectors	INPUT 1: XLR-3-31 (balanced) INPUT 2 & 3: Phone (unbalanced) LINK OUT: Phone (unbalanced)	INPUT 1: XLR-3-31/PHONE (balanced) INPUT 2/3: PHONE/RCA-PIN (unbalanced) LINK OUT: PHONE	1: XLR-3-31 (balanced) 2: XLR-3-32 (balanced) 3: PHONE (balanced) (All parallel)	Input (ch-A & B): XLR-3-31 (balanced) THRU Out (ch-A & B): XLR-3-32 (balanced) High Pass Out (ch-A & B): XLR-3-32 (balanced) (100 Hz, 18 dB/oct, +4 dB)
Power Requirement	AC120V/60Hz, AC230V/50Hz, AC240V/50Hz	AC100V, 110V, 120V, 220V, 230V or 240V; 50/60Hz	AC120V 60Hz, AC230V 50Hz, AC240V 50Hz, AC110V 60Hz	AC120V 60Hz, AC230V 50Hz, AC240V 50Hz, AC220V 50Hz
Power Consumption	70 W	40W	110W	200W
Finish	Polypropylene Black	Polypropylene Black	Polypropylene Black	Birch Plywood, Black sprayed
Dimensions (W x H x D mm)	275 x 455.5 x 255	342 x 544.5 x 298	406 x 667 x 351	600 x 521 x 590
Net Weight	11 kg	14.1 kg	23 kg	45 kg

* 0dB=0.775V

Simple Steps To Better Sound

Boosting system power

If the people in the back row aren't hearing the performance with the intended impact, you can add speakers to boost the system's output. The first thing to try would be adding an extra set of speakers parallel-connected with the main front speakers. In this case, it is important to add the same type of speakers as the originals. If you use speakers with different

sensitivity, only the louder speakers will be heard. Another option is to add a subwoofer to beef up the low end. By reinforcing the lows you effectively boost overall output. This is a good strategy for improving the sound in outdoor setups. If you're using Yamaha Club Series speakers, you can easily add a subwoofer adding an electronic crossover, or use the filters provided in the P-Series amplifiers.

MS101III

POWERED MONITOR SPEAKER SYSTEM

Nothing beats these small powered monitors for performance and utility. The 10-watt MS101III is an equally fine choice for your desktop studio or point-of-sale sound in a retail outlet. In the former application, the superior sound of these remarkably accurate monitors can help you make better mixes, while in the latter you can broadcast line-fed program material, or plug a microphone directly into the front-panel mic jack when you want to grab your customers' attention. MS101III can be wall- or ceiling-mounted, or conveniently mounted on a microphone stand.

Ideal For Monitoring or Point-Of-Sale Sound



MS101III

Specifications

MS101III	
Type	Bass reflex.
Frequency Range	75Hz to 18kHz
Maximum Output Level (SPL)	97dB (1m, 10W)
Component	10-cm (4") full-range cone speaker x 1
Maximum Output Power	10W
Input sensitivity	Mic: -45dB, Line1, 2: -10dB
Controls	VOLUME, Tone (High, Low), Power switch
Connectors	Line Inputs RCA pin-jack x 1 (rear panel), Phone jack x 1 (front panel), Microphone Input Phone jack x 1 (front panel), Line Output Phone jack x 1 (front panel)
Power Requirement	120V 60Hz, 230/240V 50/60Hz
Power Consumption	30W
Dimensions (W x H x D mm)	147 x 214 x 192
Net Weight	2.2 kg

POCKETRAK C24/W24

24 bit / 96kHz



POCKET RECORDERS



C24

Amazing Combination of Quality and Convenience

Looking for the best way to record your music lessons, practices, band rehearsals? You've found it. The C24 delivers 24bit/96kHz sound quality in the world's smallest size, and is packed with helpful features.

POCKETRAK C24 Features

- World's smallest and lightest recorder (2oz./57g with battery).*
- 24bit/96kHz recording capability.
- 26-hour MP3 recording time (PCM: 16 hours).
- High capacity 2GB internal memory.
- **Attachment clip included.**

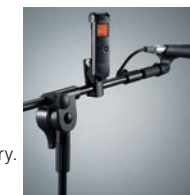

*With 24bit/96kHz capability. Based on Yamaha data.



W24

Large Stereo Mic and Ultra-handly Wireless Remote Control

Compact and lightweight, the W24 features a large dual microphone assembly for outstanding stereo sound quality. What's more, recording is more convenient than ever thanks to the supplied wireless remote control. It's the perfect choice for effortless recording in the studio, on the stage or out in the field.

POCKETRAK W24 Features

- Extremely sensitive, top quality X-Y mic.
- 24bit/96kHz recording capability.
- Pocket size, weighs only 3.25oz./92grams.
- High quality peak limiter built in.
- 38-hour PCM recording time (MP3: 56 hours).
- **Wireless Remote Control included.**



Specifications

	POCKETRAK C24	POCKETRAK W24
Memory Capacity	2 GB (External memory: microSD/microSDHC)	2 GB (External memory: microSD/microSDHC)
Battery Available Battery	AAA alkaline battery x 1	AA alkaline battery x 1
Recording Battery Life	AAA Alkaline : MP3: 26 h, PCM: 16 h	AA Alkaline : MP3: 56 h, PCM: 38 h
Playback Battery Life	AAA Alkaline : MP3: 34 h, PCM: 18 h (Earphone)	AA Alkaline : MP3: 70 h, PCM: 45 h (Earphone)
LCD Type	Dot matrix, Backlit display	Dot matrix, Backlit display
Others	Internal Stereo Microphone, Internal Speaker, Headphone Jack (Stereo mini: ø3.5mm x 1), Ext. Stereo Mic In Jack (Stereo mini: ø3.5mm, Line In Jack switchable x 1), microSD card slot x 1	Internal Stereo Microphone, Internal Speaker, Headphone Jack (Stereo mini: ø3.5mm x 1), Ext. Stereo Mic In Jack (Stereo mini: ø3.5mm, Line In Jack switchable x 1), microSD card slot x 1
Recording Format	Linear PCM, MP3	Linear PCM, MP3
Recording Time (using 2GB microSD/)	PCM stereo (96 kHz) 55m, 24 bit	PCM stereo (96 kHz) 55m, 24 bit
Frequency Response/	PCM stereo (44.1 kHz) 3h 00m, 16 bit	PCM stereo (44.1 kHz) 3h 00m, 16 bit
Sampling Frequency/	MP3 stereo (320 kbps) 13h 30m	MP3 stereo (320 kbps) 13h 30m
Bit Rate	MP3 stereo (128 kbps) 34h 00m	MP3 stereo (128 kbps) 34h 00m
	MP3 stereo (64 kbps) 68h 00m	MP3 stereo (64 kbps) 68h 00m
Recording Other Functions	Voice Automatic Recording System, ALC (Auto Level Control) ON/OFF, Mic Sensitivity Select (ALC ON: 2 steps, ALC OFF: 80 steps), Recording Peak Limiter, 5-band Graphic Equalizer (8 presets/User), High Pass Filter, Timer rec, Self Timer, Rec monitor, File delete confirmation, Scene Memory	Voice Automatic Recording System, ALC (Auto Level Control) ON/OFF, Mic Sensitivity Select (ALC ON: 2 steps, ALC OFF: 80 steps), Recording Peak Limiter, 5-band Graphic Equalizer (8 presets/User), High Pass Filter, Timer rec, Self Timer, Rec monitor, File delete confirmation, Scene Memory
Playback Format	MP3, WMA, WAV (WAV file playback is own recording file only)	MP3, WMA, WAV (WAV file playback is own recording file only)
Musical Function	5-band EQ (Presets: Flat, Bass1, Bass2, Pop, Rock, Jazz, User)	5-band EQ (Presets: Flat, Bass1, Bass2, Pop, Rock, Jazz, User)
Playback Speed (Not available on PCM)	Slow PB (50 - 100 %), Normal (100 %), Fast PB (100 - 200 %)	Slow PB (50 - 100 %), Normal (100 %), Fast PB (100 - 200 %)
Playback Other Functions	Play list Playback, Skip Search, File edit (divide, fade in/ out), Tuner, Metronome	Play list Playback, Skip Search, File edit (divide, fade in/ out), Tuner, Metronome
Dimensions (W x H x D mm)	37.6 x 113.0 x 21.1	46.5 x 129.5 x 17.5
Weight	57 g including battery	92 g including battery
Accessories	Alkaline AAA battery, Attachment clip, Cubase AIS DVD-ROM, Owner's Manual	Alkaline AA battery, Wireless remote controller, Windscreen, Microphone stand adaptor, USB cable, Cubase AIS DVD-ROM, Owner's Manual

* Continuous recording time will depend on the type of battery used as well as the battery's manufacturer, the conditions under which the battery is being used, and the condition under which it has been stored. Proper operation cannot be guaranteed when a battery other than the supplied eneloop battery or an alkaline battery from a reliable manufacturer is used.

STAGEPAS series

PORTABLE PA SYSTEM



Combining high-performance power and accurate sound reproduction with remarkable versatility in a portable package, Yamaha's STAGEPAS Series Portable PA Systems are fast becoming the standard for musicians and other PA users on the go.

These combination mixer/amplifier/speaker systems are exceptionally lightweight, portable and full-featured. Since virtually everything you need is in one, easy-to-use package, you can be set up and playing within a matter of minutes.

The series now includes the new single-speaker STAGEPAS 150M and 250M, which can be expanded to a stereo system by simply adding a second speaker. They can also function either as an ultra-portable PA system, or as a powerful keyboard amplifier with sound quality and portability that far surpasses any other conventional keyboard amp. No matter what system you choose, you have a high-power, high performance sound system ready for a wide variety of venues and events, both indoors and out.

Built-in Powered Mixer

Built-in mixer provides easy operation and convenient portability. Can be used inside the cabinet or outside.

Optional BMS-10A for Convenient Mic Stand Mounting

The detachable mixer can be conveniently mounted on a conventional microphone stand for easy access, using the optional BMS-10A Mic Stand Adaptor.



STAGEPAS 500

STAGEPAS 300

STAGEPAS 250M

STAGEPAS 150M



Versatility and Power —in Four Portable Systems

Specifications

Mixer

	STAGEPAS 500	STAGEPAS 300	STAGEPAS 250M	STAGEPAS 150M
Maximum Output Power	250 W + 250 W (±10 %) 4 Ω @ 10 % THD at 1 kHz (SPEAKER L/R)	150 W + 150 W (±10 %) 6 ± @ 10 % THD at 1 kHz (SPEAKER L/R)	250 W (±10 %) 4 ± @ 10 % THD at 1 kHz (SPEAKER)	150 W (±10 %) 6 ± @ 10 % THD at 1 kHz (SPEAKER)
Output Power (RMS)	200 W + 200 W 4 Ω @ 1 % THD at 1 kHz (SPEAKER L/R)	100 W + 100 W 6 Ω @ 1 % THD at 1 kHz (SPEAKER L/R)	200 W 4 Ω @ 1 % THD at 1 kHz (SPEAKER)	100 W 4 Ω @ 1 % THD at 1 kHz (SPEAKER)
Maximum Output Level	116 dB (1 m)	112 dB (1 m)	116 dB (1 m)	112 dB (1 m)
Frequency Response (Nominal output level @ 1 kHz)	-3 dB, 0 dB, +1 dB @ 20 Hz-20 kHz, 1 W Output (MUSIC/SPEECH=MUSIC, without Speaker EQ) (STAGEPAS 500/300: SPEAKER L/R) (STAGEPAS 250M/150M: SPEAKER)			
Total Harmonic Distortion	0.5 % @ 20 Hz, 1 kHz, 20 kHz +14 dBu GAIN= nominal (STAGEPAS 500/300: MONITOR OUT, REC OUT) (STAGEPAS 250M/150M: ST SUB OUT, ST LINK OUT)			
Hum & Noise (Equivalent Input Noise, Rs = 150 Ω, MIC/LINE = MIC)	≤ -106 dBu (CH1/2) ≤ -112 dBu (CH3/4) ≤ -65 dBu Residual output noise (SPEAKER L/R)	≤ -65 dBu Residual output noise (SPEAKER L/R)	≤ -106 dBu (CH1/2) ≤ -65 dBu Residual output noise (SPEAKER)	≤ -112 dBu (CH3/4) ≤ -65 dBu Residual output noise (SPEAKER)
Crosstalk (1kHz)	±70dB between input channels			
Power Consumption	65 W	70 W	35 W	20 W
Weight	24 kg (52-7/8" lbs.) (Speaker x 2 + Powered Mixer)	18 kg (39-5/8" lbs.) (Speaker x 2 + Powered Mixer)	13 kg (28-5/8" lbs.) (Speaker + Powered Mixer)	9.6 kg (21-1/8" lbs.) (Speaker + Powered Mixer)
Input Channel Equalization	±15 dB, HIGH 10 kHz shelving, LOW 100 Hz shelving			

Speaker

	STAGEPAS 500	STAGEPAS 300	STAGEPAS 250M	STAGEPAS 150M
Enclosure	2-way bass-reflex type, Polypropylene, Black			
Crossover Frequency	4.0 kHz (LF: 12 dB/oct, HF: 12 dB/oct)			
Frequency Range	55 Hz-20 kHz (-10 dB)			
Speaker Unit	LF: 10" (25 cm) Cone HF: 1" (2.54 cm) Compression Driver	LF: 8" (20 cm) Cone HF: 1" (2.54 cm) Compression driver	LF: 10" (25 cm) Cone HF: 1" (2.54 cm) Compression Driver	LF: 8" (20 cm) Cone HF: 1" (2.54 cm) Compression Driver

Multi-purpose Portable PA

Whether your Portable PA needs are Pro Audio (for music performance) or Public Address for school, church and meeting assemblies, the STAGEPAS systems are lightweight, compact and simple to setup—and fit a wide variety of applications.

For Bands

Multiple microphone inputs make the STAGEPAS series an ideal choice for band rehearsals and performances. The STAGEPAS 500 in particular is well suited for many sources and larger venues, while the optional MSR100 powered speakers can be used for monitoring.



For Singers

Vocalists will appreciate the built-in, high-quality reverb on all STAGEPAS systems. Plus, the 250M and 500 models feature a built-in limiter/compressor to let you dial in a smooth, punchy vocal sound.



For Instrumentalists

The versatile STAGEPAS mixer has more than enough input capability to directly handle many different instruments—from electric-acoustic guitars to electronic keyboards.



For Keyboard Players

Players needing a simple, yet exceptionally high-quality keyboard amplifier will find ideal solutions in the STAGEPAS 150M and 250M. These compact, highly portable and easy-to-use systems can serve as your main system for small gigs, or as a sub-mixer for direct connection to the main mixer at large events.



For Guitarists

The STAGEPAS 150M and 250M are excellent systems for guitarists playing in small venues, since they deliver outstanding sound for the house as well as great monitor sound for the player.



For Public Speakers

If you're a speaker or giving presentations, you can instantly optimize the system settings with the special Speech mode—giving you maximum clarity for speech applications. Naturally, you can mix background music from a CD player or other source with the mic input.



MSP STUDIO series speakers

POWERED MONITOR SPEAKER

Yamaha's "STUDIO" series monitors have been designed without compromise for serious monitoring. Years of experience and development have been applied to achieve reference-quality reproduction precision that lets you hear sonic details, rather than flattering sound. These studio-class speakers carry on in the tradition of the venerable NS10M STUDIO, which was the definitive near-field monitor in an overwhelming majority of professional studios throughout the world for many years from the 80s onward. But technology has evolved dramatically right throughout the audio chain, and speakers must follow suit. The new top-of-the-line MSP7 STUDIO Powered Monitor Speaker is capable of delivering consistent quality and performance that you can rely on in modern production environments that handle any combination of digital and analog sources as well as stereo and surround formats, while the more compact dimensions of the MSP5 STUDIO make it an ideal choice for smaller project studios and DAW-based production systems. The SW10 STUDIO subwoofer has been designed specifically for optimum matching with the MSP series speakers, and when added to either a stereo or surround system it can provide seamless extended low end for accurate ultra-wide-range monitoring.



MSP7 STUDIO SW10 STUDIO MSP5 STUDIO

Refined Monitoring Precision

Specifications

	MSP5 STUDIO	MSP7 STUDIO	SW10 STUDIO
General Specifications			
Type	Biamp 2-way Powered speaker	Biamp 2-way Powered Speaker	Powered Subwoofer
Crossover Frequency	2.5kHz, LF: 24dB/oct, HF: 24dB/oct	2.5kHz, LF: 30dB/oct, HF: 30dB/oct	—
Overall Frequency Response	50Hz – 40kHz (-10dB)	45Hz – 40kHz (-10dB)	25Hz – 150Hz (-10dB)
Dimensions (W x H x D mm)	179 x 208 x 279	218 x 235 x 330	328 x 476 x 459
Weight	7.9 kg	12.2 kg	26.5 kg
Speaker Components			
Speaker Components	LF: 5" cone, HF: 1.0" Titanium dome	LF: 6.5" cone, HF: 1.0" Titanium dome	LF: 10" cone
Enclosure Type	Bass-Reflex Type	Bass-Reflex Type	Bass-Reflex Type
Material	PP	PP	MDF
Magnetic shielding	Yes	Yes	Yes
Amp. Unit			
Output Power	LF: 40W, THD = 0.02 %, RL = 4Ω, HF: 27W, THD = 0.02 %, RL = 6Ω	LF: 80W, THD = 0.05 %, RL = 4Ω, HF: 50W, THD = 0.05 %, RL = 6Ω	LF: 180W, f = 100Hz, THD = 1 %, RL = 8Ω
Input Sensitivity	XLR-3-31: +4dBu, LEVEL = Center, -6dBu, LEVEL = Max, PHONE: -10dBu, LEVEL = Center, -20dBu, LEVEL = Max	XLR-3-31: +4dBu, LEVEL = Center, -6dBu, LEVEL = Max, PHONE: -10dBu, LEVEL = Center, -20dBu, LEVEL = Max	XLR-3-31: +4dBu, LEVEL = Center, -6dBu, LEVEL = Max, PHONE: -10dBu, LEVEL = Center, -20dBu, LEVEL = Max
Input Impedance	10kΩ	10 kΩ	10 kΩ
Input Connectors	1: XLR-3-31 type (balanced) 2: PHONE (unbalanced)	XLR-3-31 type (balanced)	XLR-3-31 type x 3 (balanced)
Output Connectors	—	—	XLR-3-32 type x 3 (balanced) (parallel)
Controls	LEVEL control: 31 Positions Detent type VR (Min = ∞ Attenuation), LOW TRIM: +1.5/0/-1.5/-3 dB at 60 Hz, HIGH TRIM: +1.5/0/-1.5 dB at 15 kHz	LEVEL control: 31 Positions Detent type VR (Min = ∞ Attenuation), LOW CUT switch: FLAT/80/100Hz (12dB/oct), LOW TRIM: +1.5/0/-1.5/-3dB at 45Hz, HIGH TRIM: +1.5/0/-1.5dB at 15kHz	LEVEL control: Center Click VR (Min = ∞ Attenuation), HIGH CUT control: 40 – 120Hz, 80Hz at Center Click, PHASE switch: NORM./REV.
Power Consumption	60W	100W	160W

HS series speakers

POWERED MONITOR SPEAKER

When choosing reference monitors for mixing and music production, what you really need is an honest reference for your mix rather than sound that has been tweaked or colored to sound impressive at the expense of accuracy. Unlike speakers that have exaggerated bass and treble that make a good first impression but can't be relied on for accuracy, Yamaha HS series reference monitors have been painstakingly crafted by our studio monitor engineering team to deliver exceptionally flat, accurate response that you can trust. The HS series speakers are true studio reference monitors in the tradition of the legendary Yamaha NS10M. Whether you're mixing for stereo or 5.1 surround, mixes that sound good on Yamaha HS series reference monitors will translate accurately to the widest possible range of reproduction systems... which is engineer-speak that means they'll sound good on anything. And that is the ultimate goal of any reference monitor. We should also mention that the HS-series monitors not only sound great, they look great, too.

High-performance Speakers and Mounting System



HS50M HS10W HS80M

Specifications

	HS50M	HS80M	HS10W
General Specifications			
Type	Biamp 2-way Powered speaker	Biamp 2-way Powered speaker	Powered Subwoofer
Crossover Frequency	3kHz	2kHz	—
Overall Frequency Response	55Hz – 20kHz (-10dB)	42Hz – 20kHz (-10dB)	30Hz – 180Hz (-10dB)
Dimensions (W x H x D mm)	165 x 268 x 222	250 x 390 x 332	300 x 350 x 386
Weight	5.8 kg	11.3 kg	12.5 kg
Speaker Components			
Speaker Components	LF: 5" cone, HF: 0.75" Dome	LF: 8" cone, HF: 1" Dome	LF: 8" cone
Enclosure Type	Bass-Reflex Type	Bass-Reflex Type	Bass-Reflex Type
Material	MDF	MDF	MDF
Magnetic shielding	Yes	Yes	Yes
Amp. Unit			
Output Power	LF: 45W, 4Ω, HF: 25W, 8Ω	LF: 75W, 4Ω, HF: 45W, 8Ω	LF: 150W, 4Ω
Input Sensitivity	XLR-3-31: -10 dBu, PHONE: (parallel)	XLR-3-31: -10dBu, PHONE: (parallel)	XLR-3-31: -10dBu, PHONE: (parallel)
Input Impedance	10kΩ	10kΩ	10kΩ
Input Connectors	1: XLR-3-31 type (balanced) 2: PHONE (balanced) (parallel)	1: XLR-3-31 type (balanced) 2: PHONE (balanced) (parallel)	1: XLR-3-31 type (balanced) 2: PHONE (balanced) (parallel)
Output Connectors	—	—	1: XLR-3-32 type (balanced) x 1 (EXT SUB) 2: XLR-3-32 type (balanced) x 2 (L&R)
Controls	LEVEL control: +4dB, center click, LOW CUT switch: FLAT/80/100Hz, 12dB/octave, HIGH TRIM: +2/0/-2dB at 3kHz (HF), EQ: MID: +2/0/-2dB at 2kHz, ROOM CONTROL: 0/-2/-4dB under 500Hz	LEVEL control: +4dB, center click, LOW CUT switch: FLAT/80/100Hz, 12dB/octave, HIGH TRIM: +2/0/-2dB at 3kHz (HF), EQ: MID: +2/0/-2dB at 2kHz, ROOM CONTROL: 0/-2/-4 dB under 500Hz	LEVEL control: VR, LOW CUT switch: ON/OFF, LOW CUT control: 80 – 120Hz at Center Click, HIGH CUT control: 80 – 120Hz at Center Click, PHASE switch: NORM./REV.
Power Consumption	45 W	60W	70W

Speaker Brackets

Wall Brackets

For MSR100/STAGEPAS300

- BWS50-190
- BWS50-260
- BWS50-320

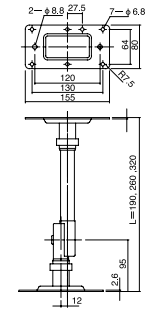

Wall Brackets

For MSR400/STAGEPAS500

- BWS251-300
- BWS251-400

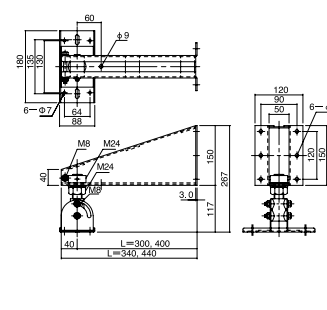

Baton Brackets

For MSR100/MSR400/STAGEPAS300/STAGEPAS500

- BBS251

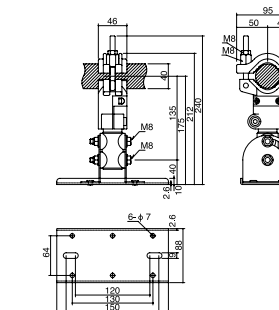

Ceiling Brackets

For MSR100/MSR400/STAGEPAS300/STAGEPAS500

- BCS251

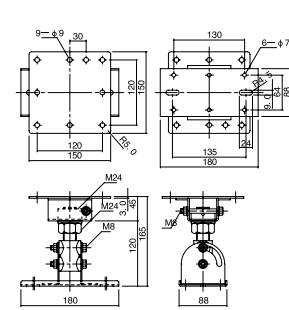

Rack Mount Adaptors

RK512

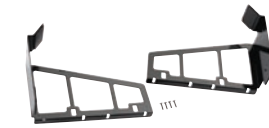

For EMX512SC/EMX312SC/EMX212C

RK5014



For EMX5014C/EMX5016CF

RK-1



For 01V96VCM

Mic Stand Adaptor

BMS-10A



For MG82CX/MG102C/STAGEPAS 300 (Mixer only)/STAGEPAS 500 (Mixer only)/STAGEPAS 150M (Mixer only)/STAGEPAS 250M (Mixer only)

Foot Switch

FC5



Headphones

RH-5MA



Not all peripherals are available in all areas. Contact the local Yamaha subsidiary for availability.

Mini-YGDAI Compatible Cards

For 01V96VCM

Mini-YGDAI Card Name	Function	Input	Output
MY4-AD	Analog In	4 In	—
MY8-AD24	Analog In	8 In	—
MY8-AD96	Analog In	8 In	—
MY4-DA	Analog Out	—	4 Out
MY8-DA96	Analog Out	—	8 Out
MY8-ADDA96	Analog In/Out	8 In	8 Out
MY8-AE	AES/EBU	8 In	8 Out
MY8-AE96	AES/EBU	8 In	8 Out

Mini-YGDAI Card Name	Function	Input	Output
MY8-AE96S	AES/EBU	8 In	8 Out
MY16-AE	AES/EBU	16 In	16 Out
MY8-AT	ADAT	8 In	8 Out
MY16-AT	ADAT	16 In	16 Out
MY8-TD	TASCAM	8 In	8 Out
MY16-TD	TASCAM	16 In	16 Out
MY16-CII	CobraNet	16 In	16 Out

For more options and information, please visit our website at <http://www.yamahaproaudio.com>



For details please contact:

YAMAHA CORPORATION
P.O. BOX 1, Hamamatsu Japan
www.yamahaproaudio.com
www.yamaha.com/proaudio



This document is printed on chlorine-free (ECF) paper with soy ink.

Printed in Japan